

DATA SHEET

Premium Efficiency Motor: **PEWWE75-36-365TS**

60 Hz

WorldWide Electric Corporation

1 (800) 808-2131

Worldwideelectric.net



Document Generated: 15-Feb-2023

Document ID:

Customer:

MOTOR INFORMATION

HP	75
RPM	3600
Phase	3
Frequency	60 Hz
Voltage	230/460 V
Frame Size	365TS
Enclosure	TEFC
Degree of Protection	IP55
Service Factor	1.25
Poles	2
Full Load Speed	3560
Insulation Class	F
Temp Rise	80°C
NEMA Code Letter	G
Duty Cycle	S1 / Continuous
Slip	1.10%
NEMA Design	B
Moment of Inertia	8.6 lb.ft.^2
Locked Rotor Time (Hot)	13 seconds
Sound Pressure Level	78 dB(A)
Number of Starts	2 Cold/ 1 Hot
Max Ambient Temperature	40°C
Max Elevation	1000 m.a.s.l (3300 f.a.s.l)
Mounting	F1
Rotation	Bi-Directional
Area of Classification	Class I, Division 2, Groups A, B, C, D
Inverter Rating	10:1 CT / 20:1 VT PWM Type
Standard	NEMA MG-1
Approvals	CSA-US, CE

EFFICIENCY/POWER FACTOR

LOAD	EFF	P. F.
100%	93.6 %	0.85
75%	93.6 %	0.83
50%	92.9 %	0.77

TORQUE

FULL LOAD	LRT	BDT
111 lb.ft.	195 %	230 %

AMPERAGE INFORMATION

	230V	460V
Full Load Amps	177A	88.3A
Locked Rotor Amps	1085A	542.5A
No Load Current	50A	25A
Usable at 208V	195A	

BEARING INFORMATION

DE Bearing	6313 C3
ODE Bearing	6312 C3
Grease Type	SKF LGHP 2
DE Regreasing Interval	1800 Hours
ODE Regreasing Interval	2400 Hours

ADDITIONAL DATA

F2 Suitable	Yes
Shaft Material	1045 Carbon Steel
Connection Diagram	230 / 460 V - 12 Lead Δ
Approximate Weight	787 lbs.

MOTOR DRAWING

Premium Efficiency Motor: **PEWWE75-36-365TS**

WorldWide Electric Corporation

1 (800) 808-2131

Worldwideelectric.net

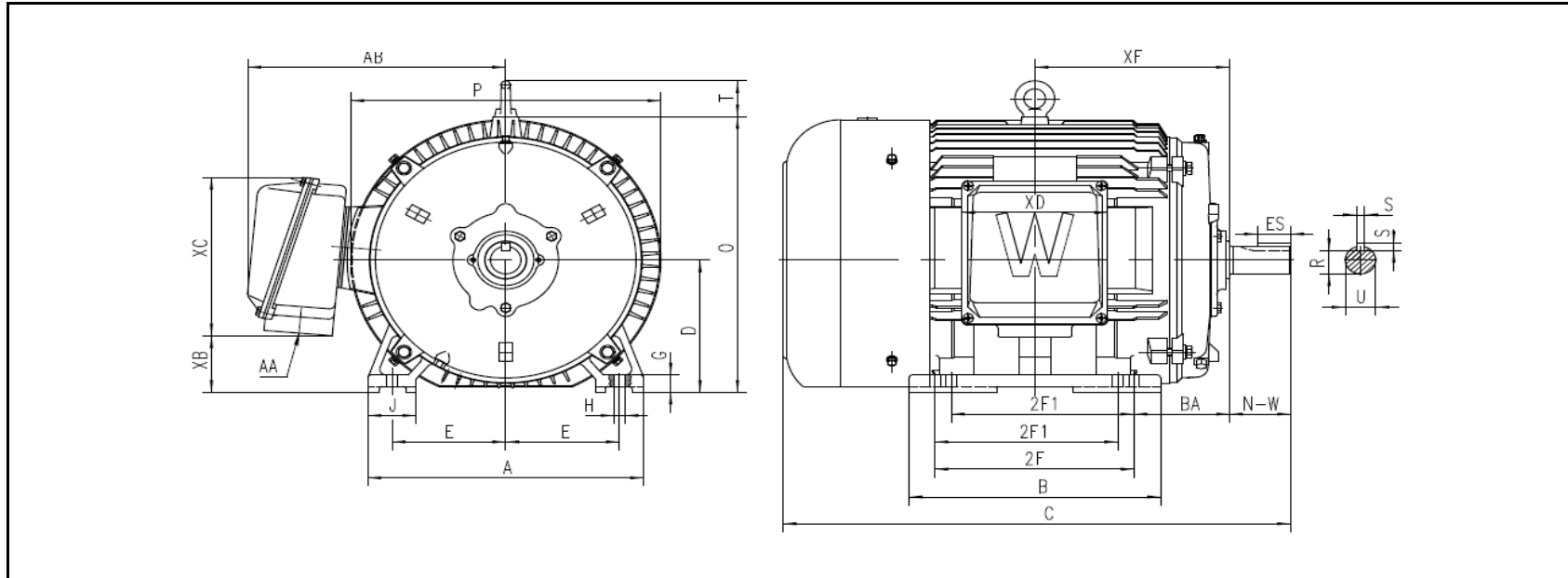

DIMENSION - INCHES

MOUNTING					A	B	C	D	G	J	P	O	T	AB
E	2F1	2F	H	BA										
7	11.25	12.25	0.66	5.88	16.969	15.472	31.23	9	1.181	2.953	19.091	18.8	2.441	15.899

SHAFT & KEY				
S	ES	R	N-W	U
0.5	2.03	1.591	3.75	1.875

TERMINAL BOX				
AA	XB	XC	XD	XF
3	3.849	10.783	8.976	11.988

PERFORMANCE CURVES

WorldWide Electric Corporation

1 (800) 808-2131

Worldwideelectric.net



Premium Efficiency Motor:

PEWWE75-36-365TS

Document Generated: 15-Feb-2023
Document ID:

Customer:

Motor Type	PEWWE		FL Speed	3560		
Output Rating (HP)	75		LRT (%FLT)	195	460 volt FLA	88.3 A
Full Load Torque	111 lb.ft		BDT (%FLT)	230	230 volt FLA	177 A
Rotor Wk ²	8.6 lb-ft ²					

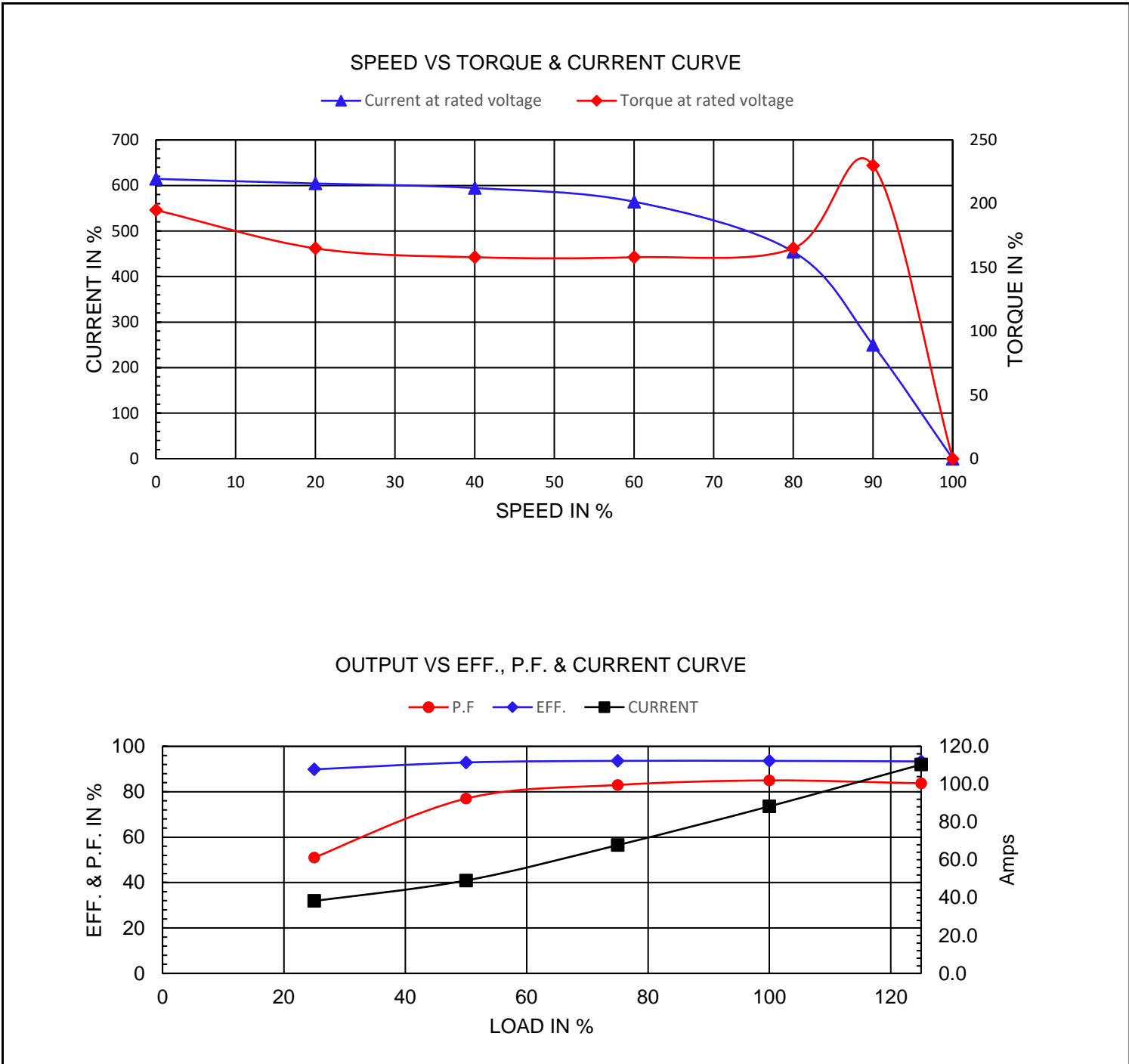

NAMEPLATE / WIRING

WorldWide Electric Corporation

1 (800) 808-2131

Worldwideelectric.net



Premium Efficiency Motor:

PEWWE75-36-365TS

Document Generated: 15-Feb-2023
Document ID:

Customer:

SAMPLE NAMEPLATE DATA

		NEMA Premium		3-PHASE INDUCTION MOTOR		259277 	 CC006A
Model	<input type="text"/>	Ser No.	<input type="text"/>				
HP	<input type="text"/>	S.F.	<input type="text"/>	IP	<input type="text"/>	Encl	<input type="text"/>
Frame	<input type="text"/>	P.F.	<input type="text"/>	Code	<input type="text"/>	Type	<input type="text"/>
Voltage	230/460	Hz	<input type="text"/>	Ins Cl	<input type="text"/>	Rating	°C Amb Cont
Amps	<input type="text"/>	RPM	<input type="text"/>	Design	<input type="text"/>	Date	<input type="text"/>
Nom.Eff.	FL	%	3/4	%	230/460 V	10:1 CT	20:1 VT PWM VFD 1.0SF
Class I DIV. 2 Groups A B C D		Amb.40°C					
Class I Zone 2 IIC		Amb.55°C					
		DE Brng					
		ODE Brng					
		Grease type: LGHP 2 (compatible with polyrex)					
50Hz	HP	V	A	rpm	1.0SF		

Model

HP S.F. IP Encl

Frame P.F. Code Type

Voltage Hz Ins Cl Ambient

Amps RPM Design DE Brng 6313 C3

Nom.Eff. ODE Brng 6312 C3

Grease type: SKF LGHP 2

50Hz 75 HP 200/400 V 204/102 A 2960 rpm