

Windjammer[®]

Model: 150999-50

MECHANICAL

NOMINAL BLOWER SIZE: 3.0 in DISCHARGE
TYPE: Tangential
DISCHARGE SIZE: Ø.79 in
INLET: Ø0.80 in bellmouth
APPROXIMATE WEIGHT: 11 oz (312 g)

TEMPERATURE

OPERATING TEMP: 0°C to 40°C
STORAGE TEMP: -40°C- to 85°C

ELECTRICAL

SUPPLY VOLTAGE: 0-28VDC
BLDC CONTROLLER: BUILT-IN WITH
TACHOMETER OUTPUT
SPEED PROPORTIONAL TO SUPPLY VOLTAGE

REGULATORY CERTIFICATIONS

COMPLIANCE: RoHS and REACH

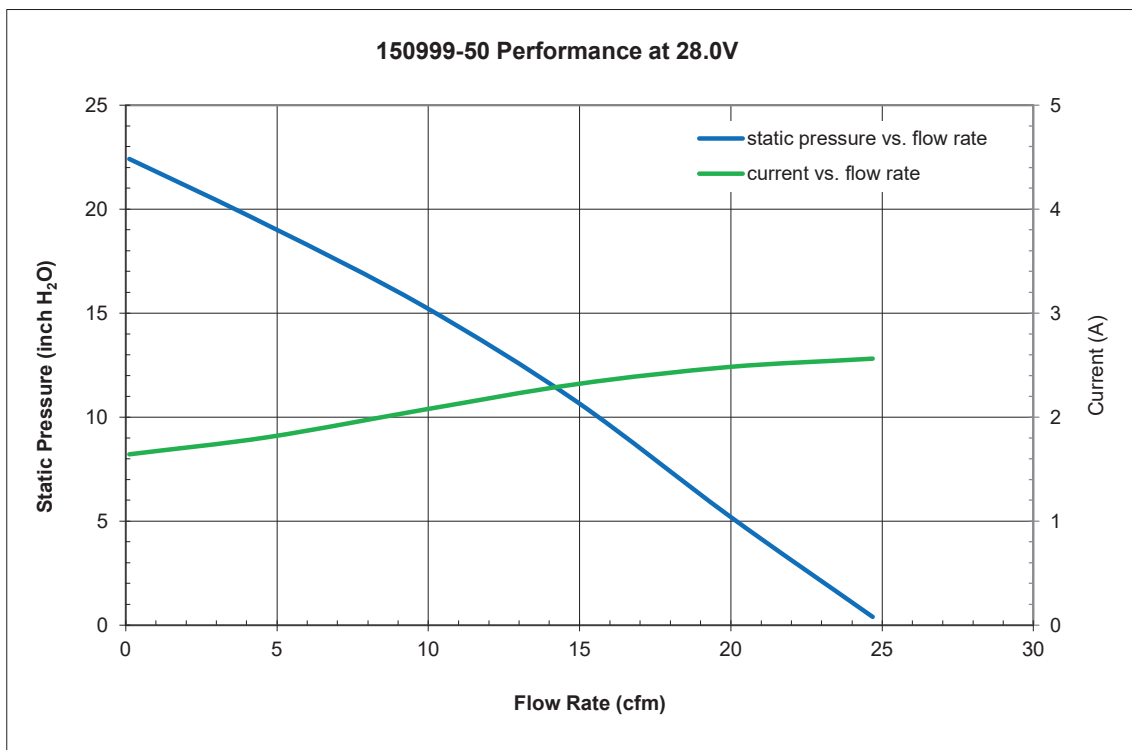

Flow Rate <i>cfm</i>	Static Pressure <i>inch H2O</i>	Current <i>A</i>	Power Demand <i>W</i>	Voltage <i>V</i>	Rotational Speed <i>rpm</i>	Static Efficiency <i>%</i>
24.7	0.4	2.6	68.0	28.0	23845	1.7
19.9	5.3	2.5	65.6	28.0	24600	19.2
14.9	10.8	2.3	61.3	28.0	25875	31.3
9.8	15.3	2.1	54.9	28.0	27735	33.0
4.7	19.2	1.8	47.9	28.0	30235	23.8
0.1	22.4	1.6	43.1	28.0	32260	0.7

NOTES: Typical performance - there will be some variation in a population.
Corrected to Standard Air Density (1.2 kg/m3).

- NOTES:
1. BLOWER OUTPUT PROPORTIONAL TO INPUT VOLTAGE.
 2. FIXED VOLTAGE TO POWER DRIVE ELECTRONICS RED AND WHITE WIRES MAY BE TERMINATED TOGETHER BUT, OPERATION BELOW 19V IS UNRELIABLE.
 3. DO NOT APPLY VOLTAGE ACROSS RED-BLACK WITHOUT FIRST POWERING THE DRIVE ELECTRONICS (WHITE-BLACK). DOING SO WILL DAMAGE THE MOTOR WINDING.
 4. ROHS AND REACH COMPLIANCE. REFERENCE AMETEK ENVIRONMENTAL SPECIFICATION ES0010 FOR DETAILS.

(4) LEADS, UL STYLE 3266
 RED: 20 AWG
 BLACK: 20 AWG
 BROWN: 24 AWG
 WHITE: 24 AWG

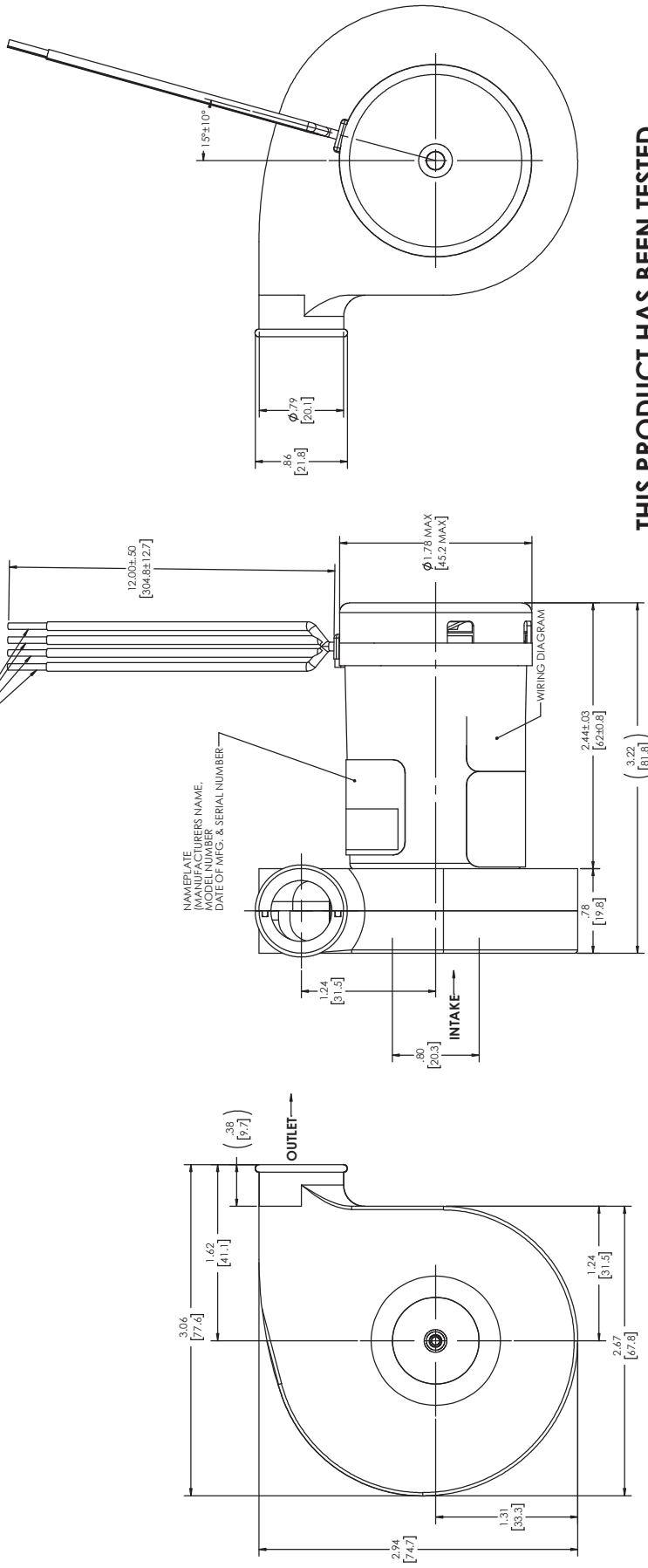

THIS PRODUCT HAS BEEN TESTED AND VALIDATED TO BE ACCEPTABLE IN OUR APPLICATION.

APPROVED BY: _____
 PRINT NAME: _____
 TITLE: _____
 DATE: _____
 COMPANY: _____

