



## Main

Range of Product	Modicon TM3
Product or Component Type	Input/output analog module
Range Compatibility	Modicon M221 Modicon M241 Modicon M251 Modicon M262
Analogue input number	4
Analogue input type	Current 4...20 mA Current 0...20 mA Voltage 0...10 V Voltage - 10...10 V
Analogue output number	2
Analogue output type	Current 4...20 mA Current 0...20 mA Voltage 0...10 V Voltage - 10...10 V

## Complementary

Analogue input resolution	12 bits 11 bits + sign
Permissible continuous overload	13 V voltage 40 mA current
Input impedance	<= 50 Ohm current >= 1 MOhm voltage
Analogue output resolution	12 bits 11 bits + sign
LSB value	2.44 mV 0...10 V voltage 4.88 mV - 10...10 V voltage 4.88 µA 0...20 mA current 3.91 µA 4...20 mA current
Load type	Resistive
Load impedance ohmic	1 kOhm voltage 300 Ohm current
Stabilisation time	1 ms
Conversion time	1 ms + 1 ms per channel + 1 controller cycle time
Sampling duration	1 Ms 10 ms
Absolute accuracy error	+/- 1 % of full scale +/- 0.2 % of full scale 77 °F (25 °C)
Temperature drift	+/- 0.01 %FS/°C
Repeat accuracy	+/-0.5 %FS input +/-0.5 %FS output
Non-linearity	+/- 0.2 %FS
Output ripple	20 mV
Cross talk	<= 1 LSB
[Us] rated supply voltage	24 V DC
Supply voltage limits	20.4...28.8 V
Type of cable	Twisted shielded pairs cable <98.43 ft (30 m) input/output
Current consumption	45 mA 5 V DC via bus connector no load 55 mA 5 V DC via bus connector full load 55 mA 24 V DC via external supply no load 100 mA 24 V DC via external supply full load

The information provided in this documentation contains general descriptions and/or technical characteristics of the performance of the products contained herein. This documentation is not intended as a substitute for and is not to be used for determining suitability or reliability of these products for specific user applications. It is the duty of any such user or integrator to perform the appropriate and complete risk analysis, evaluation and testing of the products with respect to the relevant specific application or use thereof. Neither Schneider Electric Industries SAS nor any of its affiliates or subsidiaries shall be responsible or liable for misuse of the information contained herein.

Local signalling	For PWR 1 LED (green)
Electrical connection	10 x 1.5 mm <sup>2</sup> removable spring terminal block pitch 3.81 mm for inputs 10 x 1.5 mm <sup>2</sup> removable spring terminal block pitch 3.81 mm for inputs, outputs and supply
Insulation	Between input and supply 1500 V AC Between input and internal logic 500 V AC Between output and supply 1500 V AC Between output and internal logic 500 V AC
Marking	CE
Surge withstand	1 KV power supply common mode EN/IEC 61000-4-5 0.5 KV power supply differential mode EN/IEC 61000-4-5 1 KV I/O common mode EN/IEC 61000-4-5 0.5 kV I/O differential mode EN/IEC 61000-4-5
Mounting support	Top hat type TH35-15 rail IEC 60715 Top hat type TH35-7.5 rail IEC 60715 Plate or panel with fixing kit
Height	3.54 in (90 mm)
Depth	2.76 in (70 mm)
Width	0.93 in (23.6 mm)
Net Weight	0.22 lb(US) (0.1 kg)

## Environment

Standards	EN/IEC 61131-2 EN/IEC 61010-2-201
Resistance to electrostatic discharge	8 KV in air EN/IEC 61000-4-2 4 kV on contact EN/IEC 61000-4-2
Resistance to electromagnetic fields	9.14 V/m (10 V/m) 80 MHz...1 GHz EN/IEC 61000-4-3 2.74 V/m (3 V/m) 1.4 GHz...2 GHz EN/IEC 61000-4-3 0.91 V/m (1 V/m) 2 GHz...3 GHz EN/IEC 61000-4-3
Resistance to magnetic fields	98.43 A/m (30 A/m) EN/IEC 61000-4-8
Resistance to fast transients	1 kV EN/IEC 61000-4-4 I/O)
Resistance to conducted disturbances	10 V 0.15...80 MHz EN/IEC 61000-4-6 3 V spot frequency (2, 3, 4, 6.2, 8.2, 12.6, 16.5, 18.8, 22, 25 MHz) Marine specification (LR, ABS, DNV, GL)
Electromagnetic emission	Radiated emissions 40 dB $\mu$ V/m QP class A 10 m)30...230 MHz EN/IEC 55011 Radiated emissions 47 dB $\mu$ V/m QP class A 10 m)230...1000 MHz EN/IEC 55011
Immunity to microbreaks	10 ms
Ambient Air Temperature for Operation	14...131 °F (-10...55 °C) horizontal installation 14...95 °F (-10...35 °C) vertical installation
Ambient Air Temperature for Storage	-13...158 °F (-25...70 °C)
Relative humidity	10...95 %, without condensation in operation) 10...95 %, without condensation in storage)
IP Degree of Protection	IP20
Pollution degree	2
Operating altitude	0...6561.68 ft (0...2000 m)
Storage altitude	0.00...9842.52 ft (0...3000 m)
Vibration resistance	3.5 mm 5...8.4 Hz DIN rail 3 gn 8.4...150 Hz DIN rail
Shock resistance	15 gn 11 ms

## Ordering and shipping details

Category	22533 - M2XX PLC & ACCESSORIES
Discount Schedule	MSX
GTIN	3606480648953
Nbr. of units in pkg.	1
Package weight(Lbs)	6.88 oz (195 g)
Returnability	Yes
Country of origin	JP

## Packing Units

Unit Type of Package 1	PCE
Package 1 Height	2.95 in (7.5 cm)
Package 1 width	4.92 in (12.5 cm)
Package 1 Length	4.13 in (10.5 cm)
Unit Type of Package 2	S02
Number of Units in Package 2	9
Package 2 Weight	5.06 lb(US) (2.294 kg)
Package 2 Height	5.91 in (15 cm)
Package 2 width	11.81 in (30 cm)
Package 2 Length	15.75 in (40 cm)

## Offer Sustainability

Sustainable offer status	Green Premium product
California proposition 65	WARNING: This product can expose you to chemicals including: Lead and lead compounds, which is known to the State of California to cause cancer and birth defects or other reproductive harm. For more information go to <a href="http://www.P65Warnings.ca.gov">www.P65Warnings.ca.gov</a>
REACH Regulation	<a href="#">REACH Declaration</a>
EU RoHS Directive	Pro-active compliance (Product out of EU RoHS legal scope) <a href="#">EU RoHS Declaration</a>
Toxic heavy metal free	Yes
Mercury free	Yes
RoHS exemption information	<a href="#">Yes</a>
China RoHS Regulation	<a href="#">China RoHS Declaration</a>
Environmental Disclosure	<a href="#">Product Environmental Profile</a>
Circularity Profile	<a href="#">End Of Life Information</a>
WEEE	The product must be disposed on European Union markets following specific waste collection and never end up in rubbish bins.
PVC free	Yes

Dimensions

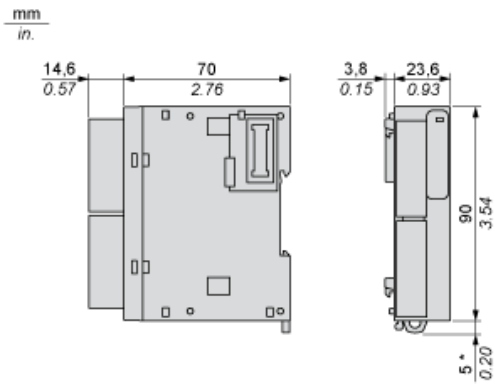

(\*) 8.5 mm/0.33 in when the clamp is pulled out.

Spacing Requirements

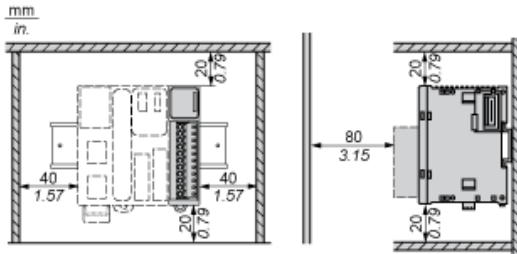

Mounting on a Rail

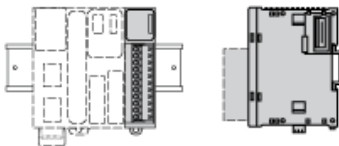

Incorrect Mounting



Mounting on a Panel Surface

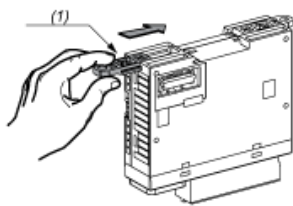

- (1) Install a mounting strip

Mounting Hole Layout

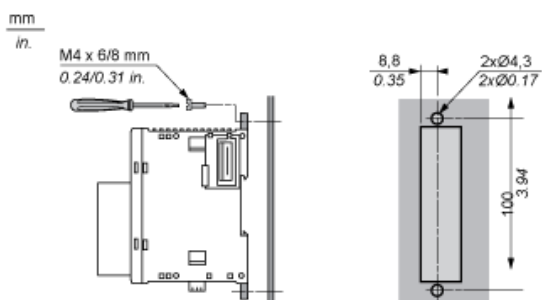

Analogue Mixed I/O Module

Wiring Diagram (Current / Voltage)

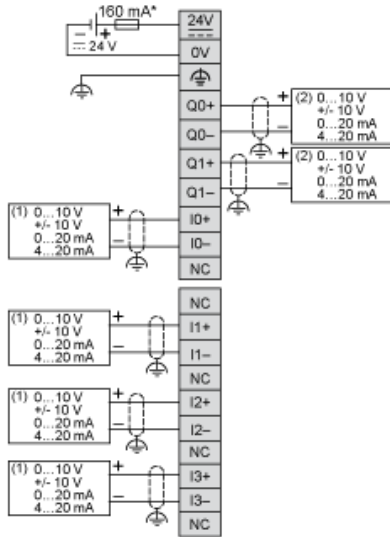

- (\*) Type T fuse
- (1) Current/Voltage analog output device
- (2) Current/Voltage analog input device