

Magelis GTO

Quick Reference Guide

Guide de référence rapide

Kurzanleitung

Guía de Referencia Rápida

Guida rapida

快速参考指南

01/2012

Table of Contents

Overview

Package Contents	4
------------------------	---

Electrical Specifications

1. HMIGTO1300/1310/2300/2310/2315/3510/4310	5
2. HMIGTO5310/5315/6310/6315	6

Part Numbers and Functions

1. HMIGTO1300/1310	7
2. HMIGTO2300/2310/2315	8
3. HMIGTO3510/4310	10
4. HMIGTO5310/5315	11
5. HMIGTO6310/6315	12
6. LED Indications	13

Interface

1. Connection for Serial Interface	15
2. RS-232C	16
3. RS-232C/RS-485	17
4. RS-485	18

Installation

1. Installation Requirements	19
2. Installation Procedure (except HMIGTO2315/5315/6315)	21
3. Removal Procedure (except HMIGTO2315/5315/6315)	25
4. Installation Procedure (HMIGTO2315/5315/6315)	26

Wiring

Wiring	30
--------------	----

USB Cable Clamp

1. Attaching the USB Type A Cable Clamp	34
2. Removing the USB Type A Cable	36
3. Attaching the USB mini-B Cable Clamp	36
4. Removing the USB Holder	37

Standards

Relevant Standards	38
--------------------------	----

Package Contents

The following items are included in the package. Before using the Magelis GTO, please confirm that all items listed here are present:

- 1 Magelis GTO: 1
- 2 Installation gasket: 1 (attached to the Magelis GTO)
- 3 Installation fasteners: 4 per set
- 4 Brackets: 4
- 5 M4 Hex Nuts: 8
- 6 DC power supply connector: 1
- 7 USB cable clamp Type A: 1 set (1 clip and 1 tie)
- 8 USB cable clamp mini-B: 1 (1 USB holder)
- 9 Magelis GTO Quick Reference Guide (this guide): 1

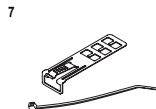
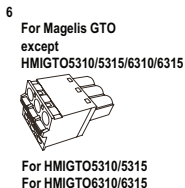
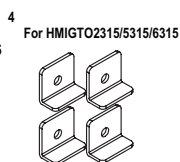
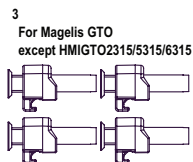
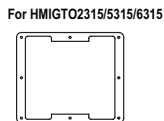
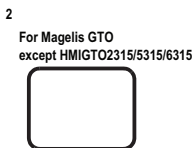
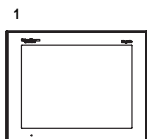

This panel has been carefully packed, with special attention to quality. However, should you find anything damaged or missing, contact your local distributor immediately.

1. HMIGTO1300/1310/2300/2310/2315/3510/4310

Specification		HMIGTO1300 HMIGTO1310	HMIGTO2300 HMIGTO2310 HMIGTO2315	HMIGTO3510 HMIGTO4310
Power Supply	Rated Input Voltage	24 Vdc		
	Input Voltage Limits	19.2...28.8 Vdc		
	Voltage Drop	2 ms or less	5 ms or less	
	Power Consumption	9.6W or less	10.5W or less	12W or less
	When power is not supplied to external devices	5.2W or less	6.5W or less	8W or less
	Backlight is OFF (Standby Mode)	4.2W or less	4.5W or less	5W or less
	Backlight Dimmed (Brightness: 20%)	4.3W or less	5W or less	5.5W or less
In-Rush Current	30 A or less			
Voltage Endurance	1,000 Vac, 20 mA for 1 min (between charging and FG terminals)			
Insulation Resistance	500 Vdc, 10 MΩ or more (between charging and FG terminals)			

2. HMIGTO5310/5315/6310/6315

Specification		HMIGTO5310/HMIGTO5315/ HMIGTO6310/HMIGTO6315
Power Supply	Rated Input Voltage	24 Vdc
	Input Voltage Limits	19.2...28.8 Vdc
	Voltage Drop	10 ms or less
	Power Consumption	17W or less
	When power is not supplied to external devices	12W or less
	Backlight OFF (Standby Mode)	7W or less
	Backlight Dimmed (Brightness: 20%)	8W or less
In-Rush Current	30 A or less	
Voltage Endurance	1,000 Vac, 20 mA for 1 min (between charging and FG terminals)	
Insulation Resistance	500 Vdc, 10 MΩ or more (between charging and FG terminals)	

1. HMIGTO1300/1310

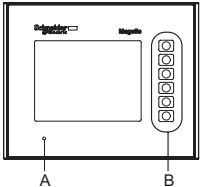
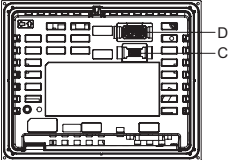
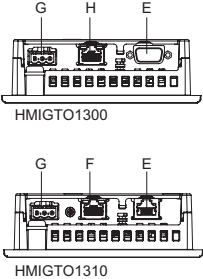
Front	
Rear	
Bottom	 <p style="text-align: center;">HMIGTO1300</p> <p style="text-align: center;">HMIGTO1310</p>

- A: Status LED (see page 13)
- B: Function Switches
- C: USB (mini-B) Interface
- D: USB (Type A) Interface
- E: Serial Interface (COM1)
- F: Ethernet Interface (see page 13)
- G: Power Plug Connector
- H: Serial Interface (COM2)

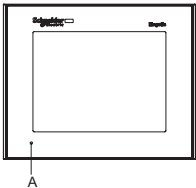
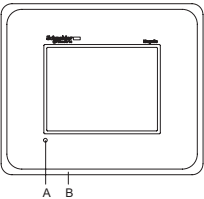
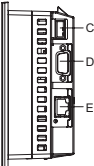
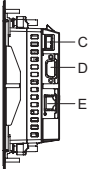
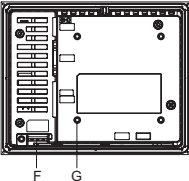
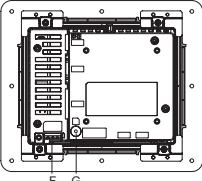
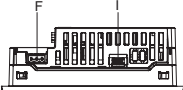
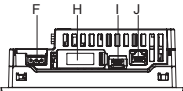
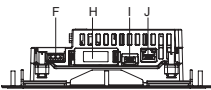

2. HMIGTO2300/2310/2315

	HMIGTO2300/2310	HMIGTO2315
Front		
Right		
Rear		
Bottom	 <p>HMIGTO2300</p>  <p>HMIGTO2310</p>	

- A: Status LED (see page 13)
- B: Stainless Steel Bezel
- C: USB (Type A) Interface
- D: Serial Interface (COM1)
- E: Serial Interface (COM2) (see page 13)
- F: Power Plug Connector
- G: SD Card Access LED (see page 13)*¹
- H: SD Card Interface Cover/Replacement Battery Insertion Cover*¹
- I: USB (mini-B) Interface
- J: Ethernet Interface (see page 13)

*¹ Only for HMIGTO2310 and HMIGTO2315.

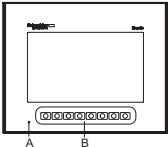
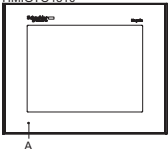
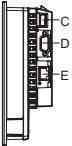
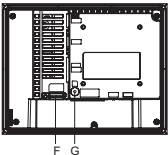
3. HMIGTO3510/4310

Front	<p>HMIGTO3510</p>  <p>HMIGTO4310</p> 
Right	
Rear	
Bottom	



A: Status LED (see page 13)

B: Function Switches

C: USB (Type A) Interface

- D: Serial Interface (COM1)
 E: Serial Interface (COM2) (see page 13)
 F: Power Plug Connector
 G: SD Card Access LED (see page 13)
 H: SD Card Interface Cover/Replacement Battery Insertion Cover
 I: USB (mini-B) Interface
 J: Ethernet Interface (see page 13)

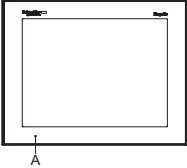
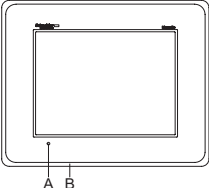
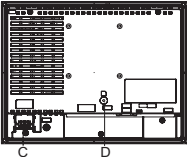
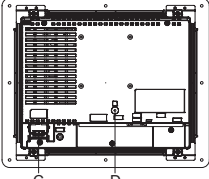
4. HMIGTO5310/5315

	HMIGTO5310	HMIGTO5315
Front		
Rear		
Bottom		

- A: Status LED (see page 13)
 B: Stainless Steel Bezel
 C: Power Plug Connector
 D: SD Card Access LED (see page 13)
 E: Ethernet Interface (see page 13)
 F: USB (mini-B) Interface



G: SD Card Interface Cover/Replacement Battery Insertion Cover

H: Serial Interface (COM2) (see page 13)

I: Serial Interface (COM1)

J: USB (Type A) Interface

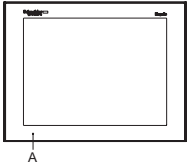
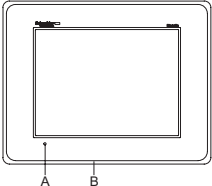
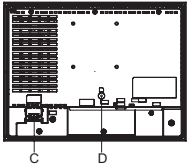
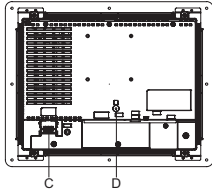
5. HMIGTO6310/6315

	HMIGTO6310	HMIGTO6315
Front		
Rear		
Bottom		

A: Status LED (see page 13)

B: Stainless Steel Bezel

C: Power Plug Connector

D: SD Card Access LED (see page 13)

E: Ethernet Interface (see page 13)

F: USB (mini-B) Interface

G: SD Card Interface Cover/Replacement Battery Insertion Cover

H: Serial Interface (COM2) (see page 13)

I: Serial Interface (COM1)

J: USB (Type A) Interface

6. LED Indications

(1) Status LED

Color	Indicator	Description
Green	ON	Offline.
		In operation.
Orange	Flashing	Software starting up.
Red	ON	Power is turned ON.
–	OFF	Power is turned OFF.

(2) SD Card access LED

Color	Indicator	Description
Green (Active)	ON	The SD Card is inserted.
	OFF	The SD Card is not inserted or is not being accessed.

(3) Ethernet LED

	Color	Indicator	Description
	Green (Active)	Flashing	Data transmission is occurring.
		OFF	No data transmission
	Green (Link)	ON	Data transmission is available in 10BASE-T/100BASE-TX.
		OFF	No connection or subsequent transmission is NOT available.

(4) COM2 LED

Color	Indicator	Description
Yellow	ON	Communication (sending or receiving data) is occurring.
	OFF	No communication.

Serial Interface

The serial port is not isolated. The SG (signal ground) and the FG (frame ground) terminals are connected inside the panel.



DANGER

ELECTRIC SHOCK

When using the SG terminal to connect an external device to the panel:

- Verify that a short-circuit loop is not created when you set up the system.
- When you use the D-Sub 9 pin connector, connect the #5 SG terminal to remote equipment when the host (PLC) unit is not isolated. Connect the #5 SG terminal to a known reliable ground connection to reduce the risk of damaging the circuit.
- When you use the RJ-45 connector, connect the #8 SG terminal to remote equipment when the host (PLC) unit is not isolated. Connect the #8 SG terminal to a known reliable ground connection to reduce the risk of damaging the circuit.

Failure to follow these instructions will result in death or serious injury.

CAUTION

LOSS OF COMMUNICATION

- Do not put excessive stress on the communication ports.
- Securely attach communication cables to the panel wall or cabinet.
- Use only D-Sub 9 pin or RJ45 cables with a locking tab in good condition.

Failure to follow these instructions can result in injury or equipment damage.

1. Connection for Serial Interface

Pin assignments for each serial interface are described in referenced pages.

	COM1	COM2
HMIGTO1300	RS-232C (see page 16)	RS-485 (see page 18)
HMIGTO1310	RS-232C/RS-485 (see page 17)	-
HMIGTO2300	RS-232C (see page 16)	RS-485 (see page 18)
HMIGTO2310	RS-232C (see page 16)	RS-485 (see page 18)
HMIGTO2315	RS-232C (see page 16)	RS-485 (see page 18)
HMIGTO3510	RS-232C (see page 16)	RS-485 (see page 18)
HMIGTO4310	RS-232C (see page 16)	RS-485 (see page 18)
HMIGTO5310	RS-232C (see page 16)	RS-485 (see page 18)
HMIGTO5315	RS-232C (see page 16)	RS-485 (see page 18)
HMIGTO6310	RS-232C (see page 16)	RS-485 (see page 18)
HMIGTO6315	RS-232C (see page 16)	RS-485 (see page 18)

2. RS-232C

D-Sub 9 pin plug connector via an RS-232C cable.

Pin Number	RS-232C		
	Signal Name	Direction	Meaning
1	CD	Input	Carrier Detect
2	RD(RXD)	Input	Receive Data
3	SD(TXD)	Output	Send Data
4	ER(DTR)	Output	Data Terminal Ready
5	SG	–	Signal Ground
6	DR(DSR)	Input	Data Set Ready
7	RS(RTS)	Output	Request to Send
8	CS(CTS)	Input	Send Possible
9	CI(RI)/VCC	Input/–	Called Status Display +5V±5% Output 0.25A
Shell	FG	–	Frame Ground (Common with SG)

You can switch pin #9 between RI and VCC via software.

NOTICE

EQUIPMENT DAMAGE

Use only the rated current.

Failure to follow these instructions can result in equipment damage.

Interfit bracket is #4-40 (UNC).

3. RS-232C/RS-485

RJ-45 connector via an RS-232C or RS-485 cable.

Note : When setting up RS-485 communication, the cable diagram for some equipment may require polarization on the terminal side. This terminal does not require any special setting as it handles polarization automatically.

Pin Number	RS-232C/RS-485		
	Signal Name	Direction	Meaning
1	RD(RXD)	Input	Receive Data (RS-232C)
2	SD(TXD)	Output	Send Data (RS-232C)
3	NC	–	–
4	D1	Input/Output	Transfer Data (RS-485)
5	D0	Input/Output	Transfer Data (RS-485)
6	RS(RTS)	Output	Request to Send
7	NC	–	–
8	SG	–	Signal Ground
Shell	FG	–	Frame Ground (Common with SG)

4. RS-485

RJ-45 connector via an RS-485 cable.

Note : When setting up RS-485 communication, the cable diagram for some equipment may require polarization on the terminal side. This terminal does not require any special setting as it handles polarization automatically

Pin Number	RS-485		
	Signal Name	Direction	Meaning
1	NC	–	–
2	NC	–	–
3	NC	–	–
4	Line A	Input/Output	Transfer Data (RS-485)
5	Line B	Input/Output	Transfer Data (RS-485)
6	RS(RTS)	Output	Request to Send
7	NC	–	no connection
8	SG	–	Signal Ground

1. Installation Requirements

- Decide on the thickness of the enclosure wall, based on the level of strength required: 1.6 mm (0.06 in.) to 5 mm (0.2 in.).
- Check that the installation panel or cabinet's surface is flat, in good condition and has no jagged edges.
- Even if panel thickness is within recommend range for "Panel Cut Dimensions", the panel could warp, depending on panel's material, size, and installation location of Magelis GTO or other devices. To prevent panel warpage, the installation surface may need to be strengthened.
- Be sure that the surrounding air temperature and the ambient humidity are within their designated ranges.

Surrounding air temperature:

0 to 50 °C (32 to 122 °F): HMIGTO1300/1310, HMIGTO2300, HMIGTO3510.

0 to 55 °C (32 to 131 °F): HMIGTO2310/2315, HMIGTO4310, HMIGTO5310/5315, HMIGTO6310/6315.

Ambient humidity: 10 to 90%RH; wet bulb temperature: maximum 39 °C (102 °F).

When installing the Magelis GTO in a cabinet or enclosure, the surrounding air temperature is the cabinet's or enclosure's internal temperature.

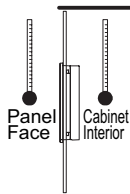

- Be sure that heat from surrounding equipment does not cause the Magelis GTO to exceed its standard operating temperature.
- When mounting the Magelis GTO vertically, ensure that the right side of the panel faces up. In other words, the power connector for DC model should be at the top.

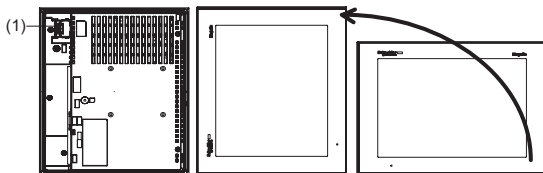

(1) Power Connector

Installation

- When installing the Magelis GTO in a slanted position, the Magelis GTO face should not incline more than 30°.

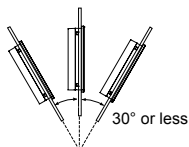

- When installing the Magelis GTO in a slanted position with an incline more than 30°, the ambient temperature must not exceed 40 °C (104 °F). You may need to use forced air cooling (fan, A/C) to ensure the ambient operating temperature is 40°C or less (104 °F or less).
- For easier maintenance, operation and improved ventilation, install the Magelis GTO at least 100 mm (3.94 in.) away from adjacent structures and other equipment as shown in the following illustration.

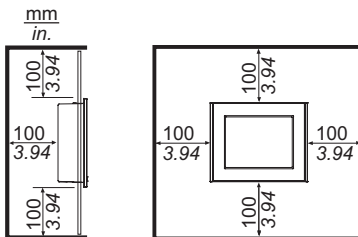

- The holes on the rear of the Magelis GTO (except HMIGTO1300/1310) are not correspondent with VESA 75mm standards. Do not attach the Magelis GTO to the commercial-type VESA arm.

2. Installation Procedure (except HMIGTO2315/5315/6315)

NOTICE

PANEL UNSTEADY WHEN UNSECURED

Keep Magelis GTO stabilized in the panel-cut while you are installing or removing the screw fasteners.

Failure to follow these instructions can result in equipment damage.

Step	Action
1	Place the Magelis GTO on a clean and level surface with the display facing downward.
2	Check that the Magelis GTO's gasket is seated securely into the gasket's groove, which runs around the perimeter of the panel frame. Note: It is strongly recommended that you use the installation gasket, since it absorbs vibration in addition to repelling water. For the procedure for replacing the installation gasket, refer to "Magelis GTO User Manual".

- 3 Create a Panel Cut and insert the Magelis GTO into the panel from the front.

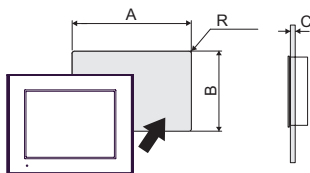

HMIGTO1300/1310

A	B	C	R
118.5 ⁺¹ ₋₀ mm (4.67 ^{+0.04} ₋₀ in.)	92.5 ⁺¹ ₋₀ mm (3.64 ^{+0.04} ₋₀ in.)	1.6...5 mm (0.06...0.2 in)	3 mm (0.12 in.) maximum

HMIGTO2300/2310

A	B	C	R
156 ⁺¹ ₋₀ mm (6.14 ^{+0.04} ₋₀ in.)	123.5 ⁺¹ ₋₀ mm (4.86 ^{+0.04} ₋₀ in.)	1.6...5 mm (0.06...0.2 in)	3 mm (0.12 in.) maximum

HMIGTO3510/HMIGTO4310

A	B	C	R
204.5 ⁺¹ ₋₀ mm (8.05 ^{+0.04} ₋₀ in.)	159.5 ⁺¹ ₋₀ mm (6.28 ^{+0.04} ₋₀ in.)	1.6...5 mm (0.06...0.2 in)	3 mm (0.12 in.) maximum

HMIGTO5310

A	B	C	R
259 ⁺¹ ₋₀ mm (10.2 ^{+0.04} ₋₀ in.)	201 ⁺¹ ₋₀ mm (7.91 ^{+0.04} ₋₀ in.)	1.6...5 mm (0.06...0.2 in)	3 mm (0.12 in.) maximum

HMIGTO6310

A	B	C	R
301.5 ⁺¹ ₋₀ mm (11.87 ^{+0.04} ₋₀ in.)	227.5 ⁺¹ ₋₀ mm (8.96 ^{+0.04} ₋₀ in.)	1.6...5 mm (0.06...0.2 in)	3 mm (0.12 in.) maximum

- 4 Insert the installation fasteners into the Magelis GTO's insertion slots on the top and bottom sides (left and right sides for the HMIGTO1300/1310.) If the fasteners are not correctly attached, the Magelis GTO may shift or fall out.

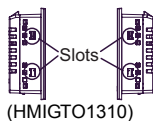
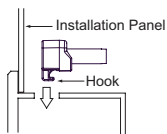

(HMIGTO1310)

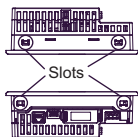

(HMIGTO2310)

- 5 Slide the fasteners to the back.

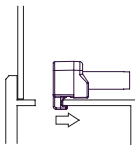

- 6 Use a screwdriver to tighten each fastener screw and secure the Magelis GTO in place. The necessary torque is 0.5 Nm (4.4 lb-in).

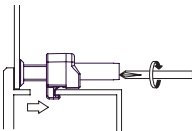

NOTICE

BROKEN ENCLOSURE

- Do not exert more than 0.5 Nm (4.4 in-lb) of torque when tightening the fastener's screws.
- Use on a flat surface of a Type 1, Type 4X (Indoor Use Only) or Type 13 Enclosure.

Failure to follow these instructions can result in equipment damage.

3. Removal Procedure (except HMIGTO2315/5315/6315)

Step	Action
1	Loosen the installation fasteners (4) from the Magelis GTO.
2	Remove the Magelis GTO slowly from the panel while pressing the projections on the top of the Magelis GTO.

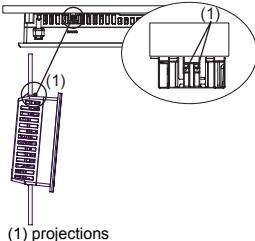

(1) projections

Note :

- You could damage the Magelis GTO if you try and remove it without holding down the projections.
- Watch your fingers so they do not get caught when holding down the projections.

⚠ CAUTION

RISK OF INJURY

Do not drop the Magelis GTO when you remove it from the panel.

- Hold the Magelis GTO in place after removing the fasteners.
- Use both hands.

Failure to follow the instruction can result in injury or equipment damage.

4. Installation Procedure (HMIGTO2315/5315/6315)

CAUTION

RISK OF INJURY

Do not drop the Magelis GTO when you install and remove it from the panel.

- Hold the Magelis GTO in place after removing the M4 Hex nuts and brackets.
- Use both hands.

Failure to follow the instruction can result in injury or equipment damage.

NOTICE

PANEL UNSTEADY WHEN UNSECURED

Keep Magelis GTO stabilized in the panel-cut while you are installing or removing the M4 Hex nuts and brackets.

Failure to follow these instructions can result in equipment damage.

Step	Action
1	Place the Magelis GTO on a clean and level surface with the display facing downward.
2	Confirm that the Magelis GTO's gasket is seated properly on the rear of the Magelis GTO.

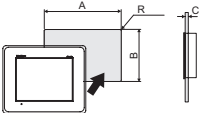
Step	Action																								
3	<p data-bbox="223 151 819 205">Create a Panel Cut and insert the Magelis GTO into the panel from the front.</p>  <p data-bbox="218 384 368 409">HMIGTO2315</p> <table border="1" data-bbox="218 416 876 550"> <thead> <tr> <th data-bbox="218 416 384 452">A</th> <th data-bbox="384 416 544 452">B</th> <th data-bbox="544 416 700 452">C</th> <th data-bbox="700 416 876 452">R</th> </tr> </thead> <tbody> <tr> <td data-bbox="218 452 384 550">195⁺¹₋₀ mm (7.68^{+0.04}₋₀ in.)</td> <td data-bbox="384 452 544 550">162.5⁺¹₋₀ mm (6.40^{+0.04}₋₀ in.)</td> <td data-bbox="544 452 700 550">1.6...5 mm (0.06...0.2 in)</td> <td data-bbox="700 452 876 550">3 mm (0.12 in.) maximum</td> </tr> </tbody> </table> <p data-bbox="218 591 368 615">HMIGTO5315</p> <table border="1" data-bbox="218 623 876 757"> <thead> <tr> <th data-bbox="218 623 384 659">A</th> <th data-bbox="384 623 544 659">B</th> <th data-bbox="544 623 700 659">C</th> <th data-bbox="700 623 876 659">R</th> </tr> </thead> <tbody> <tr> <td data-bbox="218 659 384 757">298⁺¹₋₀ mm (11.73^{+0.04}₋₀ in.)</td> <td data-bbox="384 659 544 757">240⁺¹₋₀ mm (9.45^{+0.04}₋₀ in.)</td> <td data-bbox="544 659 700 757">1.6...5 mm (0.06...0.2 in)</td> <td data-bbox="700 659 876 757">3 mm (0.12 in.) maximum</td> </tr> </tbody> </table> <p data-bbox="218 773 368 797">HMIGTO6315</p> <table border="1" data-bbox="218 805 876 939"> <thead> <tr> <th data-bbox="218 805 384 841">A</th> <th data-bbox="384 805 544 841">B</th> <th data-bbox="544 805 700 841">C</th> <th data-bbox="700 805 876 841">R</th> </tr> </thead> <tbody> <tr> <td data-bbox="218 841 384 939">340.5⁺¹₋₀ mm (13.41^{+0.04}₋₀ in.)</td> <td data-bbox="384 841 544 939">266.5⁺¹₋₀ mm (10.49^{+0.04}₋₀ in.)</td> <td data-bbox="544 841 700 939">1.6...5 mm (0.06...0.2 in)</td> <td data-bbox="700 841 876 939">3 mm (0.12 in.) maximum</td> </tr> </tbody> </table>	A	B	C	R	195 ⁺¹ ₋₀ mm (7.68 ^{+0.04} ₋₀ in.)	162.5 ⁺¹ ₋₀ mm (6.40 ^{+0.04} ₋₀ in.)	1.6...5 mm (0.06...0.2 in)	3 mm (0.12 in.) maximum	A	B	C	R	298 ⁺¹ ₋₀ mm (11.73 ^{+0.04} ₋₀ in.)	240 ⁺¹ ₋₀ mm (9.45 ^{+0.04} ₋₀ in.)	1.6...5 mm (0.06...0.2 in)	3 mm (0.12 in.) maximum	A	B	C	R	340.5 ⁺¹ ₋₀ mm (13.41 ^{+0.04} ₋₀ in.)	266.5 ⁺¹ ₋₀ mm (10.49 ^{+0.04} ₋₀ in.)	1.6...5 mm (0.06...0.2 in)	3 mm (0.12 in.) maximum
A	B	C	R																						
195 ⁺¹ ₋₀ mm (7.68 ^{+0.04} ₋₀ in.)	162.5 ⁺¹ ₋₀ mm (6.40 ^{+0.04} ₋₀ in.)	1.6...5 mm (0.06...0.2 in)	3 mm (0.12 in.) maximum																						
A	B	C	R																						
298 ⁺¹ ₋₀ mm (11.73 ^{+0.04} ₋₀ in.)	240 ⁺¹ ₋₀ mm (9.45 ^{+0.04} ₋₀ in.)	1.6...5 mm (0.06...0.2 in)	3 mm (0.12 in.) maximum																						
A	B	C	R																						
340.5 ⁺¹ ₋₀ mm (13.41 ^{+0.04} ₋₀ in.)	266.5 ⁺¹ ₋₀ mm (10.49 ^{+0.04} ₋₀ in.)	1.6...5 mm (0.06...0.2 in)	3 mm (0.12 in.) maximum																						

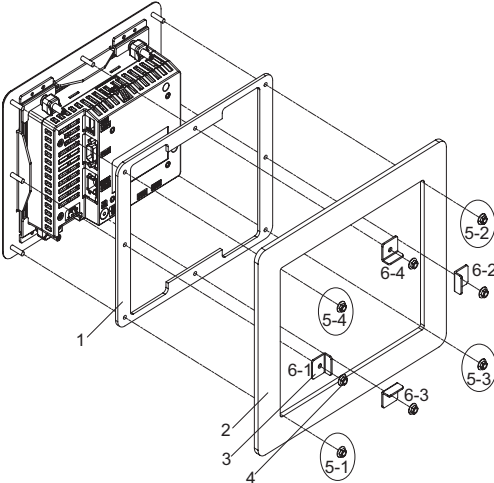
Step	Action
4	<p data-bbox="222 152 673 182">Insert the Magelis GTO into the panel-cut.</p>  <p data-bbox="222 844 486 1011"> 1 Gasket 2 Panel 3 Brackets 4 M4 Hex nuts 5 Please read Step 5. 6 Please read Step 6. </p>
5	<p data-bbox="222 1033 865 1106">Tighten the four corners of the rear of the Magelis GTO with the M4 Hex nuts, in the order shown in the example in Step 4.</p> <p data-bbox="222 1113 870 1223">Use an M4 box-type screwdriver to tighten each M4 Hex nut and secure the Magelis GTO in place. The necessary torque is 0.5 Nm (4.4 lb-in). If the M4 Hex nuts are not correctly attached, Magelis GTO may shift or fall out.</p>

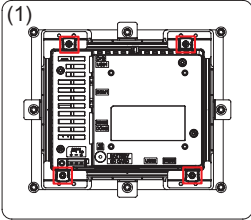
Step	Action
6	<p>Attach the bracket onto the screws in the middle between the M4 Hex nuts in the order shown in the example in Step 4. Use an M4 box-type screwdriver to tighten each M4 Hex nut and secure the Magelis GTO in place. The necessary torque is 0.5 Nm (4.4 lb-in). If the M4 Hex nuts are not correctly attached, Magelis GTO may shift or fall out.</p>
7	<p>Tighten all the M4 Hex nuts again. The necessary torque is 0.5 Nm (4.4 lb-in).</p> <p>Note : Do not loosen the installation fasteners marked with squares below.</p> <div data-bbox="239 463 565 748" style="text-align: center;"><p>(1)</p></div> <p>1 Panel</p>

NOTICE

BROKEN ENCLOSURE

- Do not exert more than 0.5 Nm (4.4 in-lb) of torque when tightening the M4 Hex nuts.
- Use on a flat surface of a Type 1, Type 4X (Indoor Use Only) or Type 13 Enclosure.

Failure to follow these instructions can result in equipment damage.

Wiring

⚠ WARNING**EXCESSIVE ELECTROMAGNETIC INTERFERENCE**

- When the functional ground (FG) terminal is connected, be sure the wire is grounded. Not grounding the Magelis GTO can result in excessive Electromagnetic Interference (EMI). Grounding is required to meet EMC level immunity.
- Remove all power from the device before removing any elements of the system, and prior to installing or removing any accessories, hardware, or cables.
- Remove power before wiring the Magelis GTO's power terminals.
- The DC model uses only 24 Vdc power. Using any other level of power can damage both the power supply and the Magelis GTO.
- Since the Magelis GTO is not equipped with a power switch, be sure to connect a power switch to the power supply.
- Be sure to ground the Magelis GTO's FG terminal.
- Replace and secure all elements of the system before applying power to the Magelis GTO.

Failure to follow these instructions can result in death, serious injury, or equipment damage.

Note: The shield ground (SG) and FG terminals are connected internally in the Magelis GTO.

Connecting the DC Power Cord

Use copper conductors only.

The temperature rating of field installed conductors: 75°C (167 °F) only.

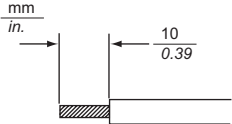
Power Cord Diameter	0.75 to 2.5 mm ² (18-13 AWG)
Conductor type	Simple or Stranded Wire*1
Conductor length	

*1 If the conductor's end (individual) wires are not twisted correctly, the end wires may either short against each other or against an electrode.

Power Connector Specifications

HMIGTO1300/1310 /
HMIGTO2300/2310/2315 /
HMIGTO3510/4310

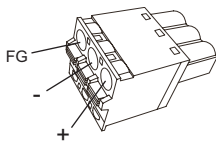

HMIGTO5310/5315 /
HMIGTO6310/6315

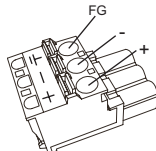

Connection	Wire
+	24 Vdc
-	0 Vdc
FG	Grounded terminal connected to the panel chassis.

How to connect the DC Power Cord

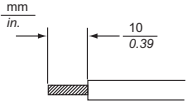
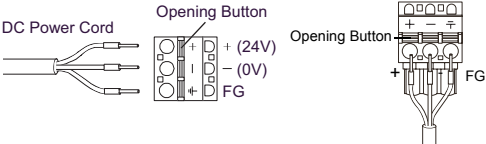
Step	Action
1	Confirm the power cord is not connected to the power supply.
2	Check the rated voltage, and remove the "DC24V" sticker on the DC power supply connector.
3	Remove 10 mm (0.39 in.) of the vinyl membrane off the ends of the power cord wires. 
4	If using stranded wire, twist the ends. Tinning the ends with solder reduces risk of fraying and ensures good electrical transfer.
5	Push the Opening button with a small and flat screwdriver to open the desired pin hole.
6	Insert each pin terminal into its corresponding holder. Release the Opening button to clamp the pin in place. HMIGTO1300/1310 / HMIGTO2300/2310/2315 / HMIGTO3510 / HMIGTO4310 HMIGTO5310/5315 / HMIGTO6310/6315 
7	After inserting all three pins, insert the DC power supply connector into the power connector on the Magelis GTO.

Note:

- Do not solder the wire directly to the power receptacle pin.
- To prevent the possibility of a terminal short, use a pin terminal that has an insulating sleeve.
- You can connect the DC power supply connector for HMIGTO1300/1310, HMIGTO2300/2310/2315, HMIGTO3510 or HMIGTO4310 to HMIGTO5310/5315 or HMIGTO6310/6315. However, the reverse is not possible. You cannot connect the DC power supply connector for HMIGTO5310/5315 or HMIGTO6310/6315 to HMIGTO1300/1310, HMIGTO2300/2310/2315, HMIGTO3510 or HMIGTO4310.

Wiring Cautions

Improving Noise/Surge Resistance

- The Magelis GTO's power supply cord should not be bundled with or kept close to main circuit lines (high voltage, high current), power lines, or input/output lines, and their various systems should be kept separate. When power lines cannot be wired via a separate system, use shielded cables for input/output lines.
- Make the power cord as short as possible, and be sure to twist the ends of the wires together (i.e. twisted pair cabling) from close to the power supply unit.
- If there is an excess amount of noise on the power supply line, connect a noise reducing transistor before turning on the power.
- Connect a surge absorber to handle power surges. Be sure to ground the surge absorber (E1) separately from the Magelis GTO (E2).

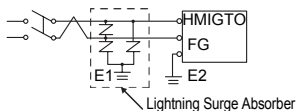

Short Circuit Prevention

- The SG (signal ground) and FG (functional ground) terminals are connected internally in the Magelis GTO. When connecting the SG line to another device, be sure that no shorting loops are formed.

Grounding

- Use an exclusive grounding wire with a grounding resistance of 100Ω or less and a wire of 2mm^2 (AWG 14) or thicker, or your country's applicable standard.

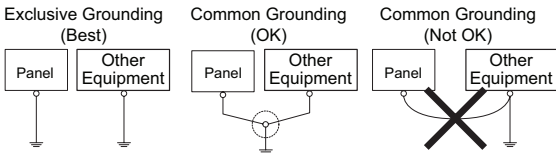

USB Cable Clamp

When using a USB device, attach a USB cable clamp to the USB interface to prevent the USB cable from being disconnected.

⚠ WARNING

RISK OF EXPLOSION IN HAZARDOUS LOCATIONS

- Verify the power, input, and output (I/O) wiring are in accordance with Class I, Division 2 wiring methods.
- Do not substitute any components that impair compliance to Class I, Division 2.
- Confirm that the USB cable has been fixed with the USB cable clamp before using the USB interface.
- Remove power before attaching or detaching any connectors to or from the panel.

Failure to follow these instructions can result in death, serious injury, or equipment damage.

1. Attaching the USB Type A Cable Clamp

Note: Watch your fingers. The edge of the clip is sharp.

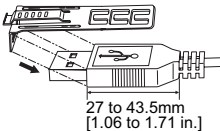
Step	Action
1	<p>Mount the clip to the USB mark  connector shell so that it overlaps. The clip matches the 27 to 43.5mm [1.06 to 1.71 inch] length of the USB connector.</p> 

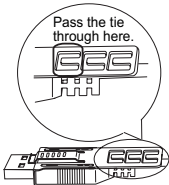
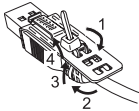
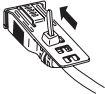
2	<p>Align the clip and the USB cable connector shell. Adjust the position of the holes where the clip is attached. To ensure stability, select the clip-hole position that is closest to the base of the connector shell.</p> 
3	<p>As shown, pass the tie through the clip hole. Next, turn the tie and pass it through the head so that the USB cable can pass through the center of the tie loop. The clip is now attached to the USB cable.</p>  <p>Note:</p> <ul style="list-style-type: none"> • Check the direction of the head beforehand. Make sure the USB cable is through the center of the tie loop and that the tie can pass through the head. • You can substitute the tie in the package or commercially available ties with a width of 4.8 mm [0.19 inch] and thickness of 1.3 mm [0.05 inch].
4	<p>While pressing the grip on the clip, insert the cable from step 3 all the way into the USB host interface. Make sure that the clip tab is secured to the USB cable attached to the Magelis GTO.</p> 

2. Removing the USB Type A Cable

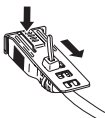
Step	Action
1	Remove the USB cable while pushing the grip section of the clip. 

3. Attaching the USB mini-B Cable Clamp

Note: Watch your fingers. The edge of the clip is sharp.

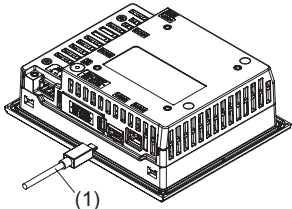
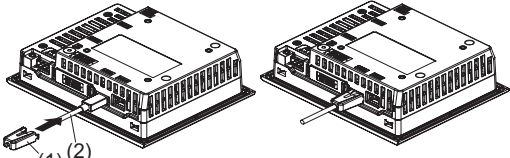
Step	Action
1	Insert the USB cable into the USB (mini-B) interface.  1 USB cable
2	Attach the USB holder to fix the USB cable in place. Insert the USB holder into the USB (mini-B) interface.  1 USB holder 2 USB cable

4. Removing the USB Holder

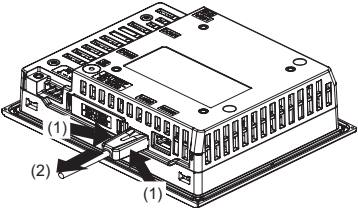
Step	Action
1	<p data-bbox="215 198 926 227">Remove the USB holder by pressing the tabs from the sides.</p>  <p data-bbox="215 515 362 573">1 USB holder 2 USB cable</p>

Relevant Standards

The Registration Model No. is as follows:

- HMIGTO1300
- HMIGTO1310
- HMIGTO2300
- HMIGTO2310
- HMIGTO2315
- HMIGTO3510
- HMIGTO4310
- HMIGTO5310
- HMIGTO5315
- HMIGTO6310
- HMIGTO6315

The Magelis GTO is manufactured in accordance with:

- Standard UL 508 and CSA C22.2 n°142 for Industrial Control Equipment

Note:

- For use in Pollution Degree 2 environments.
- For use on a flat surface of a Type 1, Type 4X (Indoor Use Only) or Type 13 Enclosure.
- 24 Vdc input panel must be used with a Class 2 power supply.
- For use in Class I, Division 2 Hazardous Locations only.
- Standard ANSI/ISA - 12.12.01 and CSA C22.2 n°213 for Electrical Equipment for Use in Class I, Division 2 Hazardous Locations
- GOST certification.
Please refer to product markings.
- ATEX certification by Technical Inspection Association.
Please refer to product label.
- Merchant Navy rules. (Except Magelis GTOxxx5.)
Products are designed to comply with Merchant Navy rules.
Please refer to the Schneider Electric Web site for Merchant Navy rules installation guidelines.
- Standard EN1672-2 (Magelis GTOxxx5).
- FDA regulation 21 CFR 177 (Magelis GTOxxx5).

WARNING

RISK OF EXPLOSION IN HAZARDOUS LOCATIONS

- Verify the power, input, and output (I/O) wiring are in accordance with Class I, Division 2 wiring methods.
- Do not substitute any components that impair compliance to Class I, Division 2.
- Do not connect or disconnect equipment unless power has been switched off or the area is non-hazardous.
- Do not disconnect while circuit is live.
- Securely lock externally connected units and each interface before turning on the power supply.
- Do not use, connect, or disconnect USB cable unless area is known to be non-hazardous.
- Potential electrostatic charging hazard: wipe the front panel of the terminal with a damp cloth before turning ON.

Failure to follow these instructions can result in death, serious injury, or equipment damage.

CAUTION

ENVIRONMENTAL HAZARDS TO THE EQUIPMENT

- Allow the device to reach the surrounding air temperature, not exceeding the following values, before turning the device on:
50°C (122°F): HMIGTO1300/1310, HMIGTO2300, HMIGTO3510.
55°C (131°F): HMIGTO2310/2315, HMIGTO4310, HMIGTO5310/5315, and HMIGTO6310/HMIGTO6315.
- Do not turn on the device if condensation has occurred inside the device. After it is completely dry again, the device may be turned on.
- Do not expose the device to direct sunlight.
- Do not obstruct the vents in the device casing.
- Remove any dust from the device before turning it on.
- Ensure that the cable installation fasteners are not damaged. Replace them, if necessary.
- Only qualified personnel can change the primary battery.
- Mount the device in enclosure that meet the IP54 level of protection for category 3G, IP6x for category 3D and the requirements relating to the 3G or 3D categories in Zones 2/22 (Category 3: normal level of protection - G: Gas - D: Dust).

Failure to follow these instructions can result in injury or equipment damage.

The Magelis GTO must be installed, used and maintained in accordance with:

- Standard WEEE, Directive 2002/96/EC
- Standard RoHS, Directive 2002/95/EC
- Standard RoHS China, Standard SJ/T 11363-2006

Table des matières

Présentation

Contenu de l'emballage.....	42
-----------------------------	----

Caractéristiques électriques

1. HMIGTO1300/1310/2300/2310/2315/3510/4310	43
2. HMIGTO5310/5315/6310/6315	44

Références et fonctions

1. HMIGTO1300/1310	45
2. HMIGTO2300/2310/2315	46
3. HMIGTO3510/4310	48
4. HMIGTO5310/5315	49
5. HMIGTO6310/6315	50
6. Indications de voyant.....	51

Interface

1. Connexion pour l'interface série	53
2. RS-232C.....	54
3. RS-232C/RS-485.....	55
4. RS-485	56

Montage

1. Conditions de montage.....	57
2. Procédure de montage (sauf HMIGTO2315/5315/6315)	59
3. Procédure de retrait (sauf HMIGTO2315/5315/6315)	63
4. Procédure de montage (HMIGTO2315/5315/6315)	64

Câblage

Câblage	68
---------------	----

Attache pour câble USB

1. Fixer l'attache pour câble USB Type A.....	73
2. Retirer le câble USB Type A.....	75
3. Fixer l'attache pour câble USB mini-B.....	75
4. Retirer le support USB.....	76

Normes

Normes applicables	77
--------------------------	----

Contenu de l'emballage

Les articles suivants sont inclus dans l'emballage. Avant d'utiliser l'équipement Magelis GTO, veuillez confirmer que tous les articles indiqués ici sont inclus :

- 1 Magelis GTO : 1
- 2 Joint de montage : 1 (fixé sur le Magelis GTO)
- 3 Attache de montage : 4 par ensemble
- 4 Supports : 4
- 5 Écrous hexagonaux M4 : 8
- 6 Connecteur d'alimentation CC : 1
- 7 Attache pour câble USB type A : 1 ensemble (une attache et un joint)
- 8 Attache pour câble USB mini-B : 1 (un support USB)
- 9 Guide de référence rapide Magelis GTO (le présent guide) : 1

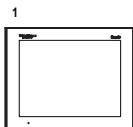

- 2 Pour les machines cibles
Magelis GTO sauf
HMIGTO2315/5315/6315



- Pour les machines cibles
HMIGTO2315/5315/6315

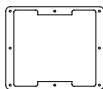

- 3 Pour les machines cibles
Magelis GTO sauf
HMIGTO2315/5315/6315

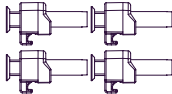

- 4 Pour les machines cibles
HMIGTO2315/5315/6315

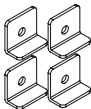

- 5 Pour les machines cibles
HMIGTO2315/5315/6315



- 6 Pour les machines cibles
Magelis GTO sauf
HMIGTO5310/5315/6310/6315



- Pour les machines cibles HMIGTO5310/5315
Pour les machines cibles HMIGTO6310/6315



7

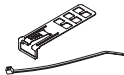

8



Ce produit a été soigneusement emballé et une attention particulière a été portée à la qualité.

Cependant, si vous constatez que des pièces sont endommagées ou manquantes, contactez immédiatement votre distributeur local.

1. HMIGTO1300/1310/2300/2310/2315/3510/4310

Spécification		HMIGTO1300 HMIGTO1310	HMIGTO2300 HMIGTO2310 HMIGTO2315	HMIGTO3510 HMIGTO4310
Alimentation	Tension d'entrée nominale	24 V c.c.		
	Limites de tension d'entrée	19,2...28,8 V c.c.		
	Chute de tension	2 ms ou moins	5 ms ou moins	
	Consommation	9,6 W ou moins	10,5 W ou moins	12 W ou moins
	Lorsque les périphériques externes ne sont pas alimentés	5,2 W ou moins	6,5 W ou moins	8 W ou moins
	Rétroéclairage éteint (mode veille)	4,2 W ou moins	4,5 W ou moins	5 W ou moins
	Rétroéclairage atténué (luminosité : 20%)	4,3 W ou moins	5 W ou moins	5,5 W ou moins
Courant d'appel	30 A ou moins			
Résistance de tension	1 000 V c.a., 20 mA pendant une minute (entre la charge et les bornes FG)			
Résistance d'isolement	500 V c.c., 10 M Ω ou plus (entre la charge et les bornes FG)			

2. HMIGTO5310/5315/6310/6315

Spécification		HMIGTO5310/HMIGTO5315/ HMIGTO6310/HMIGTO6315
Alimentation	Tension d'entrée nominale	24 V c.c.
	Limites de tension d'entrée	19,2...28,8 V c.c.
	Chute de tension	10 ms ou moins
	Consommation	17 W ou moins
	Lorsque les périphériques externes ne sont pas alimentés	12 W ou moins
	Rétroéclairage éteint (mode veille)	7 W ou moins
	Rétroéclairage atténué (luminosité : 20%)	8 W ou moins
Courant d'appel	30 A ou moins	
Résistance de tension	1 000 V c.a., 20 mA pendant une minute (entre la charge et les bornes FG)	
Résistance d'isolement	500 V c.c., 10 MΩ ou plus (entre la charge et les bornes FG)	

1. HMIGTO1300/1310

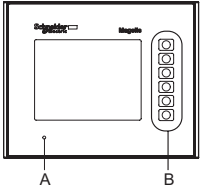
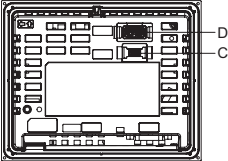
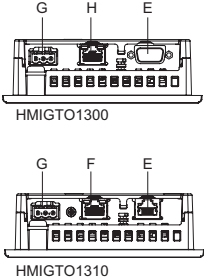
Avant	
Arrière	
Bas	 <p style="text-align: center;">HMIGTO1300</p> <p style="text-align: center;">HMIGTO1310</p>

- A : Voyant d'état(voir la page 51)
- B : Commutateurs de fonctions
- C : Interface USB (mini-B)
- D : Interface USB (Type A)
- E : Interface série (COM1)
- F : Interface Ethernet (voir la page 51)
- G : Connecteur de la fiche d'alimentation
- H : Interface série (COM2)

2. HMIGTO2300/2310/2315

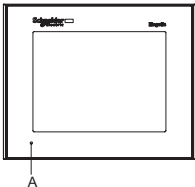
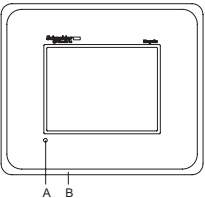
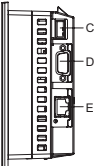
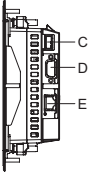
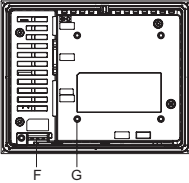
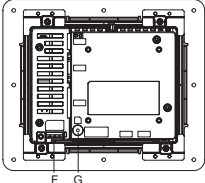
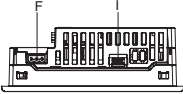
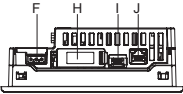
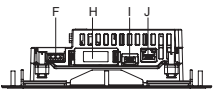
	HMIGTO2300/2310	HMIGTO2315
Avant		
Droite		
Arrière		
Bas	 HMIGTO2300  HMIGTO2310	

- A : Voyant d'état(voir la page 51)
- B : Boîtier en acier inoxydable
- C : Interface USB (Type A)
- D : Interface série (COM1)
- E : Interface série (COM2) (voir la page 51)
- F : Connecteur de la fiche d'alimentation
- G : Voyant d'accès à la carte SD (voir la page 51)^{*1}
- H : Capot d'interface de la carte SD/Capot d'insertion de la batterie de recharge^{*1}
- I : Interface USB (mini-B)
- J : Interface Ethernet (voir la page 51)

*1 Seulement pour les équipements HMIGTO2310 et HMIGTO2315.

3. HMIGTO3510/4310

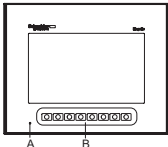
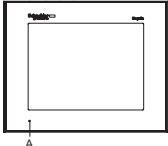
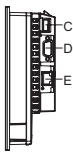
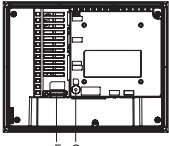
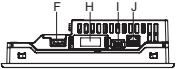
<p>Avant</p>	<p>HMIGTO3510</p>  <p>HMIGTO4310</p> 
<p>Droite</p>	
<p>Arrière</p>	
<p>Bas</p>	



A : Voyant d'état(voir la page 51)

B : Commutateurs de fonctions

C : Interface USB (Type A)

- D : Interface série (COM1)
 E : Interface série (COM2) (voir la page 51)
 F : Connecteur de la fiche d'alimentation
 G : Voyant d'accès à la carte SD (voir la page 51)
 H : Capot d'interface de la carte SD/Capot d'insertion de la batterie de rechange
 I : Interface USB (mini-B)
 J : Interface Ethernet (voir la page 51)

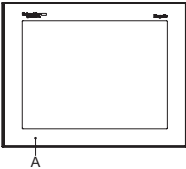
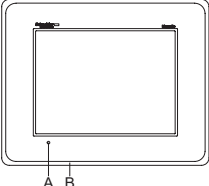
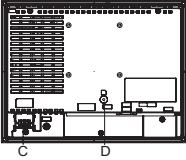
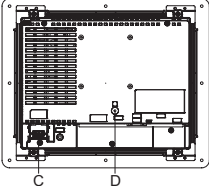
4. HMIGTO5310/5315

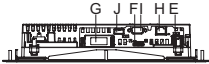
	HMIGTO5310	HMIGTO5315
Avant		
Arrière		
Bas		

- A : Voyant d'état(voir la page 51)
 B : Boîtier en acier inoxydable
 C : Connecteur de la fiche d'alimentation
 D : Voyant d'accès à la carte SD (voir la page 51)
 F : Interface Ethernet (voir la page 51)

Références et fonctions

F : Interface USB (mini-B)



G : Capot d'interface de la carte SD/Capot d'insertion de la batterie de rechange

H : Interface série (COM2) (voir la page 51)

I : Interface série (COM1)

J : Interface USB (Type A)

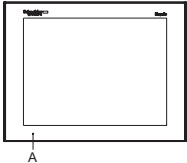
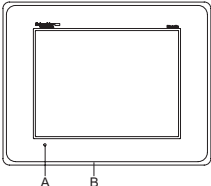
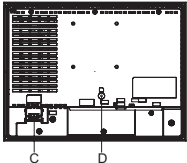
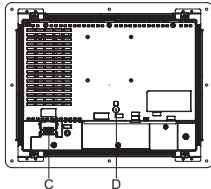
5. HMIGTO6310/6315

	HMIGTO6310	HMIGTO6315
Avant		
Arrière		
Bas		

A : Voyant d'état(voir la page 51)

B : Boîtier en acier inoxydable

C : Connecteur de la fiche d'alimentation

D : Voyant d'accès à la carte SD (voir la page 51)

F : Interface Ethernet (voir la page 51)

F : Interface USB (mini-B)

G : Capot d'interface de la carte SD/Capot d'insertion de la batterie de rechange

H : Interface série (COM2) (voir la page 51)

I : Interface série (COM1)

J : Interface USB (Type A)

6. Indications de voyant

(1) Voyant d'état

Couleur	Indicateur	Description
Vert	Allumé	Hors ligne
		En fonctionnement
Orange	Clignotant	Logiciel en cours de démarrage
Rouge	Allumé	Sous tension
–	Éteint	Hors tension

(2) Voyant d'accès à la carte SD

Couleur	Indicateur	Description
Vert (actif)	Allumé	La carte SD est insérée
	Éteint	La carte SD n'est pas insérée ou aucun équipement n'y accède

(3) Voyant Ethernet

	Couleur	Indicateur	Description
	Vert (actif)	Clignotant	Transfert de données en cours.
		Éteint	Aucune transmission de données
	Vert (lien)	Allumé	La transmission des données est disponible sur 10BASE-T/100BASE-TX
		Éteint	Aucune connexion ou transmission subséquente PAS disponible

(4) Voyant COM2

Couleur	Indicateur	Description
Jaune	Allumé	Communication (envoi ou réception des données) en cours
	Éteint	Aucune communication

Interface série

Le port série n'est pas isolé. Les bornes SG (mise à la terre du signal) et FG (masse du châssis) sont connectées à l'intérieur de l'écran.



DANGER

ÉLECTROCUTION

Lors de l'utilisation de la borne SG pour connecter un périphérique externe sur le panneau :

- Assurez-vous qu'une boucle court-circuit n'est pas créée lorsque vous configurez le système.
- Lors de l'utilisation d'un connecteur D-Sub à 9 broches, connectez la borne SG n° 5 sur l'équipement distant lorsque l'unité hôte (automate) n'est pas isolée. Connectez la borne SG n° 5 sur une connexion de masse fiable et connue afin de réduire le risque d'endommager le circuit.
- Lors de l'utilisation d'un connecteur RJ-45, connectez la borne SG n° 8 sur l'équipement distant lorsque l'unité hôte (automate) n'est pas isolée. Connectez la borne SG n° 8 sur une connexion de masse fiable et connue afin de réduire le risque d'endommager le circuit.

Le non-respect de suivre ces instructions entraînera la mort ou des blessures graves.

⚠ ATTENTION

PERTE DE COMMUNICATION

- Ne mettez pas trop de stress sur les ports de communication.
- Fixez solidement les câbles de communication au mur du panneau ou à l'armoire.
- N'utilisez que des câbles D-Sub à 9 broches ou RJ45 dotés d'une languette de verrouillage en bonne condition.

Le non-respect de suivre ces instructions peut entraîner des blessures corporelles ou des dommages matériels.

1. Connexion pour l'interface série

Les attributions de broches pour chaque interface série sont décrites dans les pages de référence.

	COM1	COM2
HMIGTO1300	RS-232C (voir la page 54)	RS-485 (voir la page 56)
HMIGTO1310	RS-232C/RS-485 (voir la page 55)	-
HMIGTO2300	RS-232C (voir la page 54)	RS-485 (voir la page 56)
HMIGTO2310	RS-232C (voir la page 54)	RS-485 (voir la page 56)
HMIGTO2315	RS-232C (voir la page 54)	RS-485 (voir la page 56)
HMIGTO3510	RS-232C (voir la page 54)	RS-485 (voir la page 56)
HMIGTO4310	RS-232C (voir la page 54)	RS-485 (voir la page 56)
HMIGTO5310	RS-232C (voir la page 54)	RS-485 (voir la page 56)
HMIGTO5315	RS-232C (voir la page 54)	RS-485 (voir la page 56)
HMIGTO6310	RS-232C (voir la page 54)	RS-485 (voir la page 56)
HMIGTO6315	RS-232C (voir la page 54)	RS-485 (voir la page 56)

2. RS-232C

Connecteur de fiche D-Sub à 9 broches au moyen d'un câble RS-232C.

Numéro de broche	RS-232C		
	Nom du signal	Direction	Signification
1	CD	Entrée	Carrier Detect (détection de porteuse)
2	RD(RXD)	Entrée	Receive Data (réception de données)
3	SD(TXD)	Sortie	Send Data (émission de données)
4	ER(DTR)	Sortie	Data Terminal Ready (terminal de données prêt)
5	SG	–	Signal Ground (masse de signal)
6	DR(DSR)	Entrée	Data Set Ready (équipement de données prêt)
7	RS(RTS)	Sortie	Request to Send (demande d'émission)
8	CS(CTS)	Entrée	Clear to send (émission possible)
9	CI(RI)/VCC	Entrée/–	Affichage d'état appelé +5V±5 % Sortie 0,25 A
Enveloppe	FG	–	Masse du châssis (reliée à SG)

Vous pouvez alterner entre RI et VCC pour la broche n° 9 au moyen du logiciel.

AVIS

DOMMAGES MATÉRIELS

N'utilisez que le courant nominal.

Le non-respect de suivre ces instructions peut entraîner des dommages matériels.

Le support universel est n° 4-40 (UNC).

3. RS-232C/RS-485

Connecteur RJ-45 au moyen d'un câble RS-232C ou RS-485.

Remarque : Lors de la configuration d'une communication RS-485, le schéma de câble pour certains équipements peut nécessiter une polarisation sur le côté de borne. Cette borne ne nécessite pas un réglage spécial car elle traite la polarisation automatiquement.

Numéro de broche	RS-232C/RS-485		
	Nom du signal	Sens	Signification
1	RD(RXD)	Entrant	Réception de données (RS-232C)
2	SD(TXD)	Sortant	Envoi de données (RS-232C)
3	NC	–	–
4	D1	Entrant/ Sortant	Transfert de données (RS-485)
5	D0	Entrée/Sortie	Transférer des données (RS-485)
6	RS(RTS)	Sortie	Request to Send (demande d'émission)
7	NC	–	–
8	SG	–	Signal Ground (masse de signal)
Enveloppe	FG	–	Masse du châssis (reliée à SG)

4. RS-485

Connecteur RJ-45 au moyen d'un câble RS-485.

Remarque : Lors de la configuration d'une communication RS-485, le schéma de câble pour certains équipements peut nécessiter une polarisation sur le côté de borne. Cette borne ne nécessite pas un réglage spécial car elle traite la polarisation automatiquement.

Numéro de broche	RS-485		
	Nom du signal	Direction	Signification
1	NC	–	–
2	NC	–	–
3	NC	–	–
4	Ligne A	Entrant/Sortant	Transfert de données (RS-485)
5	Ligne B	Entrant/Sortant	Transfert de données (RS-485)
6	RS(RTS)	Sortie	Request to Send (demande d'émission)
7	NC	–	Aucune connexion
8	SG	–	Signal Ground (masse de signal)

1. Conditions de montage

- Déterminez l'épaisseur du mur de l'enceinte en fonction du niveau de résistance requis : 1,6 mm (0,06 po) à 5 mm (0,2 po).
- Vérifiez que la surface du panneau ou de l'armoire d'installation est plane, qu'elle n'est pas endommagée et qu'elle ne présente aucune brèche.
- Même si l'épaisseur du panneau se situe dans la plage recommandée pour les « dimensions de coupe d'écran », le panneau pourrait se déformer, en fonction du matériau, de la taille et de l'emplacement du montage de l'équipement Magelis GTO et autres périphériques. Pour éviter la déformation du panneau, la surface du montage devra peut-être être renforcée.
- Assurez-vous que la température de l'air ambiant et l'humidité ambiante sont comprises dans les plages indiquées.

Température de l'air ambiant :

0 à 50 °C (32 à 122 °F) : HMIGTO1300/1310, HMIGTO2300, HMIGTO3510.

0 à 55 °C (32 à 131 °F) : HMIGTO2310/2315, HMIGTO4310, HMIGTO5310/5315, HMIGTO6310/6315.

Humidité ambiante : 10 à 90 % HR, température au bulbe humide : 39 °C (102 °F) maximum. Lors du montage de l'équipement Magelis GTO dans une armoire ou un boîtier, la température ambiante de fonctionnement est la température interne de l'armoire ou du boîtier.

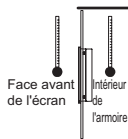

- Vérifiez que la chaleur des équipements voisins ne poussent pas l'équipement Magelis GTO à dépasser sa température de fonctionnement standard.
- Lors du montage vertical de l'équipement Magelis GTO, assurez-vous que le côté droit du panneau est orienté vers le haut. En d'autres mots, le connecteur d'alimentation pour un modèle CC devra se situer sur le dessus.

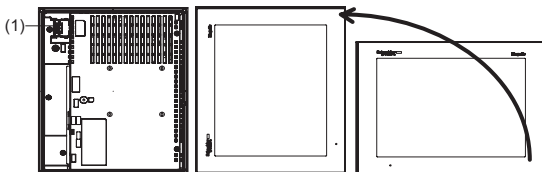

(1) Connecteur d'alimentation

- Lors du montage de l'équipement Magelis GTO dans une position inclinée, l'inclinaison ne doit pas dépasser 30°.

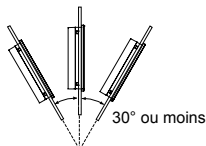

- Lors du montage de l'équipement Magelis GTO dans une position ayant une inclinaison dépassant 30°, la température ambiante ne doit pas dépasser 40 °C (104 °F). Vous pouvez utiliser un dispositif de refroidissement de l'air (ventilateur, climatiseur) pour vous assurer que la température de fonctionnement ne dépasse pas 40 °C (104 °F).
- Pour faciliter la maintenance et l'exploitation et améliorer la ventilation, veillez à installer l'équipement Magelis GTO à au moins 100 mm (3,94 po) de distance des structures adjacentes et de tout autre équipement, comme indiqué dans l'illustration suivante :

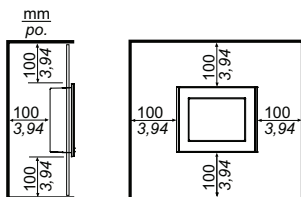

- Les trous situés à l'arrière de l'équipement Magelis GTO (sauf HMIGTO1300/1310) ne correspondent pas aux normes VESA 75 mm. N'attachez pas l'équipement Magelis GTO sur un bras VESA commercial.

2. Procédure de montage (sauf HMIGTO2315/5315/6315)

AVIS

PANNEAU INSTABLE QUAND NON SÉCURISÉ

Maintenez l'équipement Magelis GTO stable dans le gabarit lorsque vous installez ou retirez les vis de fixation.

Le non-respect de suivre ces instructions peut entraîner des dommages matériels.

Étape	Action
1	Placez l'équipement Magelis GTO sur une surface de niveau propre, l'écran d'affichage étant orienté vers le bas.
2	Vérifiez que le joint de l'équipement Magelis GTO est correctement enfoncé dans la rainure qui longe le périmètre du châssis du panneau. Remarque : Il est fortement recommandé d'utiliser le joint de montage puisque celui-ci absorbe les vibrations en plus de repousser les liquides. Pour la procédure pour remplacer le joint de montage, reportez vous au « Manuel de l'utilisateur de Magelis GTO ».

- 3 Découpez le panneau, puis insérez l'équipement Magelis GTO face avant vers le dessus.

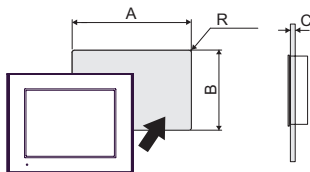

HMIGTO1300/1310

A	B	C	R
118,5 ⁺¹ ₋₀ mm (4,67 ^{+0.04} ₋₀ po)	92,5 ⁺¹ ₋₀ mm (3,64 ^{+0.04} ₋₀ po)	1,6...5 mm (0,06...0,2 po)	3 mm (0,12 po) maximum

HMIGTO2300/2310

A	B	C	R
156 ⁺¹ ₋₀ mm (6,14 ^{+0.04} ₋₀ po)	123,5 ⁺¹ ₋₀ mm (4,86 ^{+0.04} ₋₀ po)	1,6...5 mm (0,06...0,2 po)	3 mm (0,12 po) maximum

HMIGTO3510/HMIGTO4310

A	B	C	R
204,5 ⁺¹ ₋₀ mm (8,05 ^{+0.04} ₋₀ po)	159,5 ⁺¹ ₋₀ mm (6,28 ^{+0.04} ₋₀ po)	1,6...5 mm (0,06...0,2 po)	3 mm (0,12 po) maximum

HMIGTO5310

A	B	C	R
259 ⁺¹ ₋₀ mm (10,2 ^{+0.04} ₋₀ po)	201 ⁺¹ ₋₀ mm (7,91 ^{+0.04} ₋₀ po)	1,6...5 mm (0,06...0,2 po)	3 mm (0,12 po) maximum

HMIGTO6310

A	B	C	R
301,5 ⁺¹ ₋₀ mm (11,87 ^{+0.04} ₋₀ po)	227,5 ⁺¹ ₋₀ mm (8,96 ^{+0.04} ₋₀ po)	1,6...5 mm (0,06...0,2 po)	3 mm (0,12 po) maximum

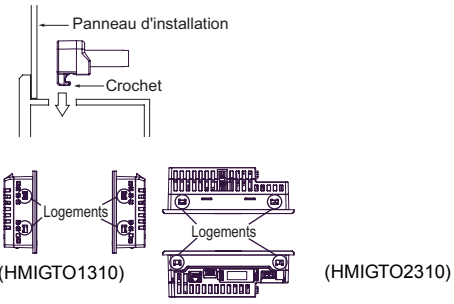
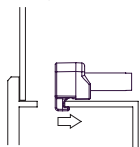
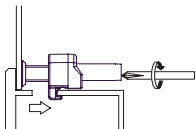
4	<p>Insérez les fixations d'installation dans les fentes d'insertion de l'équipement Magelis GTO sur les côtés dessus et dessous (les côtés gauche et droit sur l'équipement HMIGTO1300/1310.) Si les fixations ne sont pas insérées correctement, l'équipement Magelis GTO peut se déplacer ou tomber.</p>  <p>Diagram illustrating the insertion of the installation bracket into the top and bottom slots of the equipment. Labels include 'Panneau d'installation' (installation panel), 'Crochet' (hook), and 'Logements' (slots) for both HMIGTO1310 and HMIGTO2310 models.</p>
5	<p>Faites glisser les fixations vers l'arrière.</p>  <p>Diagram illustrating the installation bracket being pushed back into the equipment slots.</p>
6	<p>Utilisez un tournevis pour serrer chaque vis de fixation et positionner l'équipement Magelis GTO. Le couple nécessaire est de 0,5 Nm (4,4 lb-po).</p>  <p>Diagram illustrating the use of a screwdriver to tighten the screws on the installation bracket.</p>

AVIS

BOÎTIER BRISÉ

- Le couple de serrage des vis de fixation ne doit pas dépasser 0,5 Nm (4,4 po-lb).
- Pour utilisation sur une surface plane d'un boîtier de type 1, type 4X (usage intérieur seulement) ou type 13

Le non-respect de suivre ces instructions peut entraîner des dommages matériels.

3. Procédure de retrait (sauf HMIGTO2315/5315/6315)

Étape	Action
1	Desserrez les fixations d'installation (4) de l'équipement Magelis GTO.
2	Retirez lentement l'équipement Magelis GTO du panneau en appuyant sur les projections situés sur le dessus.

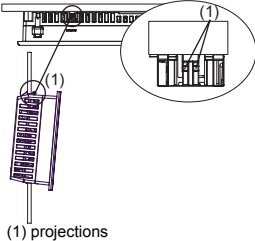

(1) projections

Remarque :

- Vous pouvez endommager l'équipement Magelis GTO si vous tentez de le retirer sans enfoncer les projections.
- Faites attention de ne pas coincer vos doigts lorsque vous enfoncez les projections.

⚠ ATTENTION

RISQUE DE BLESSURES

Ne faites pas tomber l'équipement Magelis GTO lorsque vous le retirez du panneau.

- Tenez l'équipement Magelis GTO en place après avoir retiré les fixations.
- Utilisez les deux mains.

Le non-respect de suivre ces instructions peut entraîner des blessures corporelles ou des dommages matériels.

4. Procédure de montage (HMIGTO2315/5315/6315)

⚠ ATTENTION

RISQUE DE BLESSURES

Ne faites pas tomber l'équipement Magelis GTO lorsque vous le montez dans le panneau et le retirez de celui-ci.

- Tenez l'équipement Magelis GTO en place après avoir retiré les écrous hexagonaux et les supports.
- Utilisez les deux mains.

Le non-respect de suivre ces instructions peut entraîner des blessures corporelles ou des dommages matériels.

AVIS

PANNEAU INSTABLE QUAND NON SÉCURISÉ

Maintenez l'équipement Magelis GTO stable dans le gabarit lorsque vous installez ou retirez les écrous hexagonaux M4 et les supports.

Le non-respect de suivre ces instructions peut entraîner des dommages matériels.

Étape	Action
1	Placez l'équipement Magelis GTO sur une surface de niveau propre, l'écran d'affichage étant orienté vers le bas.
2	Assurez-vous que le joint est correctement enfoncé dans l'arrière de l'équipement Magelis GTO.

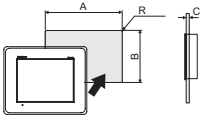
Étape	Action																								
3	<p data-bbox="222 152 839 203">Découpez le panneau, puis insérez l'équipement Magelis GTO face avant vers le dessus.</p>  <p data-bbox="217 385 367 414">HMIGTO2315</p> <table border="1" data-bbox="217 414 875 546"> <thead> <tr> <th>A</th> <th>B</th> <th>C</th> <th>R</th> </tr> </thead> <tbody> <tr> <td>195⁺¹₋₀ mm (7,68^{+0.04}₋₀ po)</td> <td>162,5⁺¹₋₀ mm (6,40^{+0.04}₋₀ po)</td> <td>1,6...5 mm (0,06...0,2 po)</td> <td>3 mm (0,12 po) maximum</td> </tr> </tbody> </table> <p data-bbox="217 589 367 618">HMIGTO5315</p> <table border="1" data-bbox="217 618 875 749"> <thead> <tr> <th>A</th> <th>B</th> <th>C</th> <th>R</th> </tr> </thead> <tbody> <tr> <td>298⁺¹₋₀ mm (11,73^{+0.04}₋₀ po)</td> <td>240⁺¹₋₀ mm (9,45^{+0.04}₋₀ po)</td> <td>1,6...5 mm (0,06...0,2 po)</td> <td>3 mm (0,12 po) maximum</td> </tr> </tbody> </table> <p data-bbox="217 771 367 800">HMIGTO6315</p> <table border="1" data-bbox="217 800 875 931"> <thead> <tr> <th>A</th> <th>B</th> <th>C</th> <th>R</th> </tr> </thead> <tbody> <tr> <td>340,5⁺¹₋₀ mm (13,41^{+0.04}₋₀ po)</td> <td>266,5⁺¹₋₀ mm (10,49^{+0.04}₋₀ po)</td> <td>1,6...5 mm (0,06...0,2 po)</td> <td>3 mm (0,12 po) maximum</td> </tr> </tbody> </table>	A	B	C	R	195 ⁺¹ ₋₀ mm (7,68 ^{+0.04} ₋₀ po)	162,5 ⁺¹ ₋₀ mm (6,40 ^{+0.04} ₋₀ po)	1,6...5 mm (0,06...0,2 po)	3 mm (0,12 po) maximum	A	B	C	R	298 ⁺¹ ₋₀ mm (11,73 ^{+0.04} ₋₀ po)	240 ⁺¹ ₋₀ mm (9,45 ^{+0.04} ₋₀ po)	1,6...5 mm (0,06...0,2 po)	3 mm (0,12 po) maximum	A	B	C	R	340,5 ⁺¹ ₋₀ mm (13,41 ^{+0.04} ₋₀ po)	266,5 ⁺¹ ₋₀ mm (10,49 ^{+0.04} ₋₀ po)	1,6...5 mm (0,06...0,2 po)	3 mm (0,12 po) maximum
A	B	C	R																						
195 ⁺¹ ₋₀ mm (7,68 ^{+0.04} ₋₀ po)	162,5 ⁺¹ ₋₀ mm (6,40 ^{+0.04} ₋₀ po)	1,6...5 mm (0,06...0,2 po)	3 mm (0,12 po) maximum																						
A	B	C	R																						
298 ⁺¹ ₋₀ mm (11,73 ^{+0.04} ₋₀ po)	240 ⁺¹ ₋₀ mm (9,45 ^{+0.04} ₋₀ po)	1,6...5 mm (0,06...0,2 po)	3 mm (0,12 po) maximum																						
A	B	C	R																						
340,5 ⁺¹ ₋₀ mm (13,41 ^{+0.04} ₋₀ po)	266,5 ⁺¹ ₋₀ mm (10,49 ^{+0.04} ₋₀ po)	1,6...5 mm (0,06...0,2 po)	3 mm (0,12 po) maximum																						

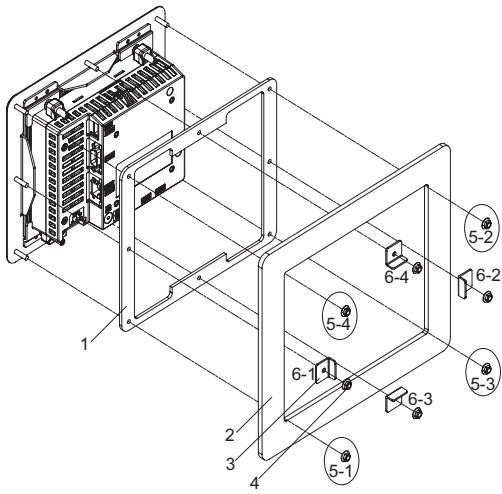
Étape	Action
4	<p data-bbox="222 152 813 203">Insérez l'équipement Magelis GTO dans l'ouverture du panneau.</p>  <p data-bbox="222 873 533 1041"> 1 Joint 2 Panneau 3 Supports 4 Écrous hexagonaux M4 5 Lisez l'étape 5. 6 Lisez l'étape 6. </p>
5	<p data-bbox="222 1055 870 1142">Serrez les quatre coins de l'arrière de l'équipement Magelis GTO à l'aide des écrous hexagonaux M4, dans l'ordre indiqué dans l'exemple de l'étape 4.</p> <p data-bbox="222 1142 870 1274">Utilisez un tournevis tête carrée M4 pour serrer chaque écrou hexagonal M4 et positionner l'équipement Magelis GTO. Le couple nécessaire est de 0,5 Nm (4,4 lb-po). Si les écrous hexagonaux M4 ne sont pas fixés correctement, l'équipement Magelis GTO peut se déplacer ou tomber.</p>

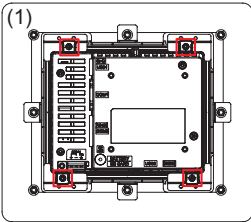
Étape	Action
6	<p>Fixez le support sur les vis dans le milieu entre les écrous hexagonaux M4 dans l'ordre indiqué dans l'exemple de l'étape 4.</p> <p>Utilisez un tournevis tête carrée M4 pour serrer chaque écrou hexagonal M4 et positionner l'équipement Magelis GTO. Le couple nécessaire est de 0,5 Nm (4,4 lb-po). Si les écrous hexagonaux M4 ne sont pas fixés correctement, l'équipement Magelis GTO peut se déplacer ou tomber.</p>
7	<p>Resserrez tous les écrous hexagonaux M4. Le couple nécessaire est de 0,5 Nm (4,4 lb-po).</p> <p>Remarque : Ne desserrez pas les fixations d'installation marquées d'un carré ci-dessous.</p> <div data-bbox="239 515 565 802" style="text-align: center;">  <p>(1)</p> </div> <p>1 Panneau</p>

AVIS

BOÎTIER BRISÉ

- Le couple de serrage des écrous hexagonaux M4 ne doit pas dépasser 0,5 Nm (4,4 po-lb).
- Pour utilisation sur une surface plane d'un boîtier de type 1, type 4X (usage intérieur seulement) ou type 13

Le non-respect de suivre ces instructions peut entraîner des dommages matériels.

▲ AVERTISSEMENT

INTERFÉRENCES ÉLECTROMAGNÉTIQUES EXCESSIVES

- Une fois la borne FG connectée, assurez-vous que le fil est relié à la terre. Si l'équipement Magelis GTO n'est pas relié à la terre, des interférences électromagnétiques (EMI) excessives peuvent survenir. La mise à la terre est requise afin d'assurer l'immunité de niveau CEM.
- Coupez l'alimentation de l'appareil avant de retirer des articles du système et avant d'installer ou de retirer des accessoires, des matériels ou des câbles.
- Coupez l'alimentation avant de câbler les bornes d'alimentation de l'équipement Magelis GTO.
- Le modèle CC ne fonctionne que sous une alimentation de 24 V c.c. Si vous utilisez un autre niveau d'alimentation, vous pouvez endommager l'alimentation et l'équipement Magelis GTO.
- L'équipement Magelis GTO n'est pas équipé d'un interrupteur ; vous devez donc en installer un sur la source d'alimentation.
- Veillez à mettre à la terre la borne FG de l'équipement Magelis GTO.
- Remplacez et fixez solidement tous les articles du système avant d'alimenter l'équipement Magelis GTO.

Le non-respect de suivre ces instructions peut entraîner la mort, des blessures graves ou des dommages matériels.

Remarque : Les bornes SG et FG sont connectées à l'intérieur de l'équipement Magelis GTO.

Branchement du cordon d'alimentation CC

Utilisez uniquement des conducteurs en cuivre.

Température des conducteurs installés sur site : 75°C (167 °F) seulement.

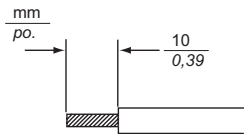
Diamètre du cordon d'alimentation	0,75 à 2.5 mm ² (18-13 AWG)
Type de conducteur	Fil simple ou multibrin*1
Longueur du conducteur	

*1 Si les fils (individuels) à l'extrémité du conducteur ne sont pas torsadés correctement, un court-circuit peut survenir sur la boucle au niveau des fils d'extrémité ou d'une électrode.

Spécifications du connecteur d'alimentation

HMIGTO1300/1310 /
HMIGTO2300/2310/2315 /
HMIGTO3510/4310

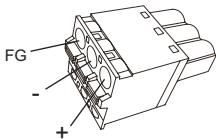

HMIGTO5310/5315 /
HMIGTO6310/6315

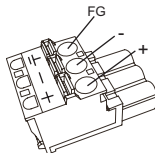

Connexion	Fil
+	24 V c.c.
-	0 V c.c.
FG	Borne de terre raccordée au châssis du panneau.

Raccordement du cordon d'alimentation CC

Étape	Action
1	Assurez-vous que le cordon d'alimentation n'est pas branché sur l'alimentation.
2	Vérifiez la tension nominale et enlevez l'autocollant « DC24V » du connecteur d'alimentation CC.
3	Dénudez la gaine en vinyle sur 10 mm (0,39 po) de chaque extrémité du fil du cordon d'alimentation. <div style="text-align: center;"> </div>
4	Pour des fils toronnés, torsadez les extrémités. L'étamage des extrémités à la soudure réduit le risque d'effilochage et assure un bon contact électrique.
5	Appuyez sur le bouton d'ouverture à l'aide d'un petit tournevis plat pour ouvrir le trou de broche désiré.
6	Insérez chaque borne à broche dans son support correspondant. Relâchez le bouton d'ouverture afin de pincer la broche en place. HMIGTO1300/1310 / HMIGTO2300/2310/2315 / HMIGTO3510 / HMIGTO4310 HMIGTO5310/5315 / HMIGTO6310/6315 <div style="display: flex; justify-content: space-around; align-items: flex-start; margin-top: 10px;"> <div style="text-align: center;"> <p>Cordon d'alimentation c.c.</p> </div> <div style="text-align: center;"> <p>Bouton d'ouverture</p> </div> <div style="text-align: center;"> <p>Bouton d'ouverture</p> </div> </div>
7	Après avoir inséré les trois broches, insérez le connecteur d'alimentation CC dans le connecteur d'alimentation sur l'équipement Magelis GTO.

Remarque :

- Ne soudez pas le fil directement sur la broche de la prise d'alimentation.
- Pour éviter la possibilité d'un court-circuit de borne, utilisez une borne à broche équipée d'une gaine isolante.

- Vous pouvez connecter le connecteur d'alimentation CC pour un équipement HMIGTO1300/1310, HMIGTO2300/2310/2315, HMIGTO3510 ou HMIGTO4310 sur un équipement HMIGTO5310/5315 ou HMIGTO6310/6315. Cependant, l'inverse n'est pas possible. Vous ne pouvez pas connecter le connecteur d'alimentation CC pour un équipement HMIGTO5310/5315 ou HMIGTO6310/6315 sur un équipement HMIGTO1300/1310, HMIGTO2300/2310/2315, HMIGTO3510 ou HMIGTO4310.

Précautions de câblage

Amélioration de la résistance au bruit ou aux surtensions

- Le cordon d'alimentation de l'équipement Magelis GTO ne doit pas être groupé avec des lignes de circuit principal (haute tension, haute intensité) ou des lignes de signal d'entrée/sortie, et leurs divers systèmes doivent être conservés séparément. Lorsqu'il est impossible de câbler les lignes électriques au moyen d'un système séparé, utilisez des câbles blindés comme lignes d'entrée/sortie.
- Réduisez au maximum la longueur du cordon d'alimentation et torsadez les extrémités des fils ensemble (p. ex., câblage à paires torsadées) à proximité du bloc d'alimentation.
- S'il y a un excès de bruit sur la ligne d'alimentation, connectez un dispositif antiparasites avant de mettre l'équipement sous tension.
- Connectez un parasurtenseur afin de gérer les surtensions. Assurez-vous de mettre à la terre le parasurtenseur (E1) séparément de l'équipement Magelis GTO (E2).

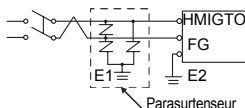

Prévention de court-circuit

- Les bornes SG (Signal Ground) et FG (Functional Ground) sont connectées à l'intérieur de l'équipement Magelis GTO. Lors du raccordement de la ligne SG sur un autre dispositif, assurez-vous qu'aucune boucle de court-circuit n'est créée.

Mise à la terre

- Utilisez un fil de mise à la terre exclusif avec une résistance de mise à la terre de 100Ω ou moins et un fil d'une épaisseur de 2 mm^2 (AWG 14) ou plus, ou la norme applicable à votre pays.

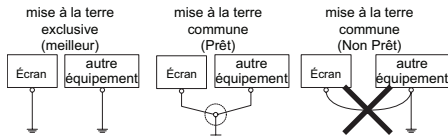

Attache pour câble USB

Lors de l'utilisation d'un périphérique USB, fixez une attache pour câble USB sur l'interface USB afin d'éviter la déconnexion du câble.

⚠ AVERTISSEMENT

RISQUE D'EXPLOSION DANS LES ENDROITS DANGEREUX

- Assurez-vous que le câblage pour l'alimentation, les entrées et les sorties (E/S) se conforme aux méthodes de câblage de la Classe I, Division 2.
- Ne remplacez pas les composants susceptibles de nuire à la conformité à la Classe I Division 2.
- Assurez-vous qu'un câble USB est fixé à l'aide d'une attache pour câble USB avant d'utiliser l'interface USB.
- Coupez l'alimentation avant de brancher ou de débrancher tout connecteur du panneau.

Le non-respect de suivre ces instructions peut entraîner la mort, des blessures graves ou des dommages matériels.

1. Fixer l'attache pour câble USB Type A

Remarque : Faites attention à vos doigts. L'arête de l'attache est coupante.

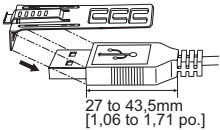
Étape	Action
1	<p>Montez l'attache sur l'enveloppe du connecteur USB ➡ pour qu'elle la recouvre partiellement. L'attache correspond à la longueur de 27 à 43,5 mm [1,06 à 1,71 pouces] du connecteur USB.</p>  <p>27 to 43,5mm [1,06 to 1,71 po.]</p>

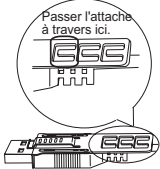
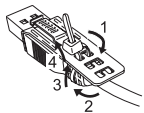
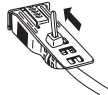
<p>2</p>	<p>Alignez l'attache à l'enveloppe du connecteur du câble USB. Ajustez la position des trous sur lesquels l'attache est fixée. Afin d'assurer la stabilité, sélectionnez la position de trou-attache la plus proche à la base de l'enveloppe du connecteur.</p> 
<p>3</p>	<p>Tel qu'illustré, passez le joint à travers le trou de l'attache. Ensuite, tournez le joint et passez-le à travers la tête pour que le câble USB puisse passer à travers le centre de la boucle du joint. L'attache est maintenant fixée sur le câble USB.</p>  <p>Remarque :</p> <ul style="list-style-type: none"> • Vérifiez à l'avance le sens de la tête. Assurez-vous que le câble USB a passé par le centre de la boucle du joint et que le joint puisse passer à travers la tête. • Vous pouvez remplacer le joint inclus dans l'emballage par des joints offerts sur le marché d'une largeur de 4,8 mm [0,19 po] et d'une épaisseur de 1,3 mm [0,05 po].
<p>4</p>	<p>En enfonçant la poignée de l'attache, insérez le câble de l'étape 3 dans l'interface hôte USB. Assurez-vous que la languette de l'attache est fixée sur le câble USB branché sur l'équipement Magelis GTO.</p> 

2. Retirer le câble USB Type A

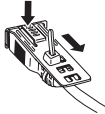
Étape	Action
1	Retirez le câble USB en appuyant sur la section de poignée de l'attache. 

3. Fixer l'attache pour câble USB mini-B

Remarque : Faites attention à vos doigts. L'arête de l'attache est coupante.

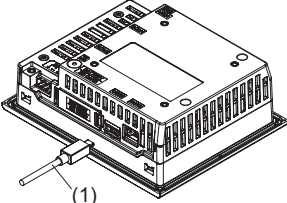
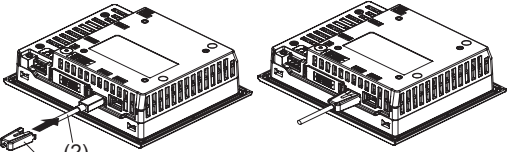
Étape	Action
1	Insérez le câble USB dans l'interface USB (mini-B).  1 Câble USB
2	Fixez le support USB afin de maintenir le câble USB. Insérez le support USB dans l'interface USB (mini-B).  1 Support USB 2 Câble USB

4. Retirer le support USB

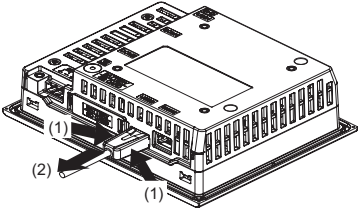
Étape	Action
1	<p data-bbox="215 198 919 248">Retirez le support USB en appuyant sur les languettes depuis les côtés.</p>  <p data-bbox="215 540 379 591">1 Support USB 2 Câble USB</p>

Normes applicables

Les numéros de modèle d'enregistrement sont les suivants :

- HMIGTO1300
- HMIGTO1310
- HMIGTO2300
- HMIGTO2310
- HMIGTO2315
- HMIGTO3510
- HMIGTO4310
- HMIGTO5310
- HMIGTO5315
- HMIGTO6310
- HMIGTO6315

L'équipement Magelis GTO est fabriqué conformément aux normes suivantes :

- UL 508 et CSA C22.2 n° 142 pour les appareils industriels de contrôle

Remarque :

- À utiliser dans un environnement de degré de pollution 2.
 - À utiliser sur une surface plane d'un boîtier de type 1, type 4X (usage intérieur seulement) ou type 13.
 - Le panneau d'entrée 24 V c.c. doit être utilisé avec une alimentation de Classe 2.
 - À utiliser dans les endroits dangereux de Classe I, Division 2.
- ANSI/ISA - 12.12.01 et CSA C22.2 n°213 pour les équipements électriques utilisés dans les endroits dangereux de Classe I, Division 2
 - Certification GOST.
Référez-vous aux marquages de produit.
 - Certification ATEX par la Technical Inspection Association.
Référez-vous à l'étiquette du produit.
 - Règles de la Marine marchande. (sauf Magelis GTOxxx5.)
Les produits sont conçus afin de se conformer aux règles de la Marine marchande.
Reportez-vous au site Web de Schneider Electric pour consulter les directives de montage selon les règles de la Marine marchande.
 - Norme EN1672-2 (Magelis GTOxxx5).
 - Réglementation de la FDA 21 CFR 177 (Magelis GTOxxx5).

⚠ AVERTISSEMENT

RISQUE D'EXPLOSION DANS LES ENDROITS DANGEREUX

- Assurez-vous que le câblage pour l'alimentation, les entrées et les sorties (E/S) se conforme aux méthodes de câblage de la Classe I, Division 2.
- Ne remplacez pas les composants susceptibles de nuire à la conformité à la Classe I Division 2.
- Assurez-vous que l'alimentation est coupée ou que la zone ne présente aucun danger avant de connecter ou déconnecter l'équipement.
- Ne déconnectez pas l'équipement lorsque le circuit sous tension.
- Verrouillez de façon sécuritaire les unités connectées à l'extérieur et chaque interface avant de mettre l'équipement sous tension.
- N'utilisez, ne connectez ou ne déconnectez pas un câble USB sauf si la zone ne présente aucun danger.
- Danger de charge électrostatique potentiel : essayez le panneau avant de la borne à l'aide d'un chiffon mouillé avant de mettre l'équipement sous tension.

Le non-respect de suivre ces instructions peut entraîner la mort, des blessures graves ou des dommages matériels.

ATTENTION

DANGERS ENVIRONNEMENTAUX

- Avant de mettre l'appareil sous tension, sa température doit atteindre la température ambiante en s'assurant de ne pas dépasser les valeurs suivantes :
50 °C (122 °F) : HMIGTO1300/1310, HMIGTO2300, HMIGTO3510.
55 °C (131 °F) : HMIGTO2310/2315, HMIGTO4310, HMIGTO5310/5315 et HMIGTO6310/HMIGTO6315.
- Ne mettez pas l'appareil sous tension s'il y a de la condensation à l'intérieur de l'appareil. Une fois complètement sèche, l'appareil peut être mis sous tension.
- N'exposez pas l'appareil à la lumière solaire directe.
- N'obstruez pas les événements du boîtier.
- Enlever toute poussière de l'appareil avant de le mettre sous tension.
- Assurez-vous que les fixations d'installation du câble ne sont pas endommagées. Remplacez-les, au besoin.
- Le remplacement de la batterie primaire ne doit être confié qu'à un personnel qualifié.
- Montez l'appareil dans une enceinte se conformant à un niveau de protection IP54 pour la catégorie 3G, IP6x pour la catégorie 3D et les exigences reliées aux catégories 3G ou 3D dans les zones 2/22 (Catégorie 3 : niveau de protection normal - G : Gaz - D : Poussière).

Le non-respect de suivre ces instructions peut entraîner des blessures corporelles ou des dommages matériels.

L'équipement Magelis GTO doit être monté, utilisé et maintenu conformément aux normes suivantes :

- WEEE, directive 2002/96/CE
- RoHS, directive 2002/95/CE
- RoHS Chine, norme SJ/T 11363-2006

Inhaltsverzeichnis

Übersicht

Lieferumfang.....	82
-------------------	----

Elektrische Kenndaten

1. HMIGTO1300/1310/2300/2310/2315/3510/4310	83
2. HMIGTO5310/5315/6310/6315	84

Teilenummern und Funktionen

1. HMIGTO1300/1310	85
2. HMIGTO2300/2310/2315	86
3. HMIGTO3510/4310	88
4. HMIGTO5310/5315	89
5. HMIGTO6310/6315	90
6. LED-Anzeigen	91

Schnittstelle

1. Anschluss serielle Schnittstelle	93
2. RS-232C.....	94
3. RS-232C/RS-485.....	95
4. RS-485	96

Installation

1. Installationsanforderungen	97
2. Montageschritte (außer HMIGTO2315/5315/6315).....	99
3. Schritte zur Demontage (außer HMIGTO2315/5315/6315).....	103
4. Montageschritte (HMIGTO2315/5315/6315)	104

Kabelverbindungen

Kabelverbindungen.....	108
------------------------	-----

USB-Kabelklemme

1. Anschluss der USB-Typ-A-Kabelklemme.....	113
2. Entfernen des USB-Typ-A-Kabels.....	115
3. Anschluss der USB-mini-B-Kabelklemme	115
4. Entfernen des USB-Halters	116

Normen

Relevante Normen.....	117
-----------------------	-----

Lieferumfang

Folgende Bestandteile sind im Lieferumfang enthalten. Bitte überprüfen Sie vor Verwendung des Magelis GTO, ob alle hier aufgeführten Bestandteile enthalten sind:

- 1 Magelis GTO: 1
- 2 Montagedichtung: 1 (am Magelis GTO befestigt)
- 3 Montagebefestigungen: 4 pro Satz
- 4 Halterungen: 4
- 5 M4 Sechskantmutter: 8
- 6 Gleichstrom-Steckverbinder: 1
- 7 USB-Kabelklemmen Typ A: 1 Satz (1 Schelle und 1 Binder)
- 8 USB-Kabelklemmen mini-B: 1 (1 USB-Halter)
- 9 Magelis GTO-Kurzanleitung (vorliegend): 1

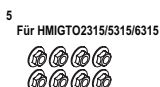
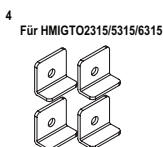
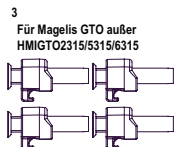
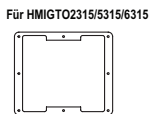
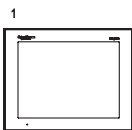

Für HMIGTO5310/5315
Für HMIGTO6310/6315

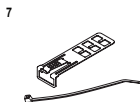

Dieses Gerät wurde sorgfältig und mit besonderer Rücksicht auf Qualität verpackt. Sollte dennoch etwas fehlen oder beschädigt sein, setzen Sie sich bitte mit einem Händler in Ihrer Nähe in Verbindung.

1. HMIGTO1300/1310/2300/2310/2315/3510/4310

Kenndaten		HMIGTO1300 HMIGTO1310	HMIGTO2300 HMIGTO2310 HMIGTO2315	HMIGTO3510 HMIGTO4310
Stromversorgung	Nominale Eingangsspannung	24 V DC		
	Grenzwerte für die Eingangsspannung	19.2...28.8 V DC		
	Spannungsabfall	2 ms oder weniger	5 ms oder weniger	
	Stromaufnahme	9,6 W oder weniger	10,5 W oder weniger	12 W oder weniger
	Wenn keine Stromversorgung an externe Geräte erfolgt	5,2 W oder weniger	6,5 W oder weniger	8 W oder weniger
	Hintergrundbeleuchtung AUS (Standby)	4,2 W oder weniger	4,5 W oder weniger	5 W oder weniger
	Hintergrundbeleuchtung gedimmt (Helligkeit: 20%)	4,3 W oder weniger	5 W oder weniger	5,5 W oder weniger
Einschaltstrom	30 A oder weniger			
Spannungsfestigkeit	1.000 V AC, 20 mA für 1 min. (zwischen Lade- und Gehäuseerdeklennen)			
Isolationswiderstand	500 V DC, 10 M Ω oder mehr (zwischen Lade- und Gehäuseerdeklennen)			

2. HMIGTO5310/5315/6310/6315

Kenndaten		HMIGTO5310/HMIGTO5315/ HMIGTO6310/HMIGTO6315
Stromversorgung	Nominale Eingangsspannung	24 V DC
	Grenzwerte für die Eingangsspannung	19.2...28.8 V DC
	Spannungsabfall	10 ms oder weniger
	Stromaufnahme	17 W oder weniger
	Wenn keine Stromversorgung an externe Geräte erfolgt	12 W oder weniger
	Hintergrundbeleuchtung AUS (Standby)	7 W oder weniger
	Hintergrundbeleuchtung gedimmt (Helligkeit: 20%)	8 W oder weniger
Einschaltstrom	30 A oder weniger	
Spannungsfestigkeit	1.000 V AC, 20 mA für 1 min. (zwischen Lade- und Gehäuseerdeklammern)	
Isolationswiderstand	500 V DC, 10 M Ω oder mehr (zwischen Lade- und Gehäuseerdeklammern)	

1. HMIGTO1300/1310

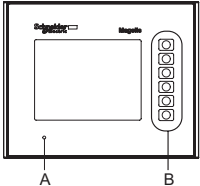
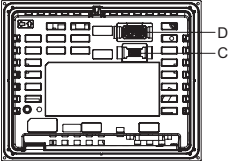
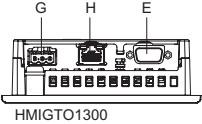
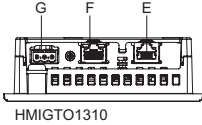
Frontseite	
Rückseite	
Unterseite	 <p style="text-align: center;">HMIGTO1300</p>  <p style="text-align: center;">HMIGTO1310</p>

- A: Status-LED (siehe Seite 91)
- B: Funktionsschalter
- C: USB-Schnittstelle (mini-B)
- D: USB-Schnittstelle (Typ A)
- E: Serielle Schnittstelle (COM1)
- F: Ethernetschnittstelle (siehe Seite 91)
- G: Netzanschluss
- H: Serielle Schnittstelle (COM2)

2. HMIGTO2300/2310/2315

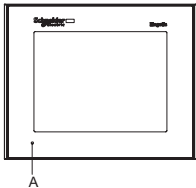
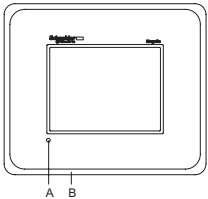
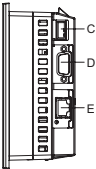
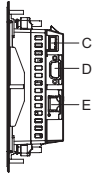
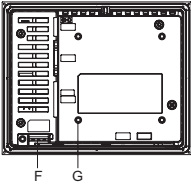
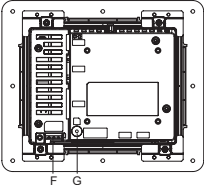
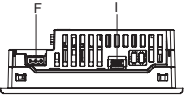
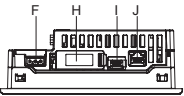
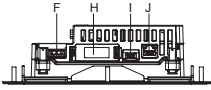
	HMIGTO2300/2310	HMIGTO2315
Frontseite		
Rechts		
Rückseite		
Unterseite	 HMIGTO2300  HMIGTO2310	

- A: Status-LED (siehe Seite 91)
- B: Edelstahlfassung
- C: USB-Schnittstelle (Typ A)
- D: Serielle Schnittstelle (COM1)
- E: Serielle Schnittstelle (COM2) (siehe Seite 91)
- F: Netzverbinder
- G: SD-Kartenzugriffs-LED (siehe Seite 91)*¹
- H: SD-Karten-Schnittstellenabdeckung/Ersatzakkufachabdeckung*¹
- I: USB-Schnittstelle (mini-B)
- J: Ethernetschnittstelle (siehe Seite 91)

*¹ Nur HMIGTO2310 und HMIGTO2315.

3. HMIGTO3510/4310

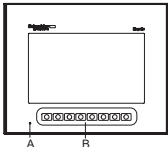
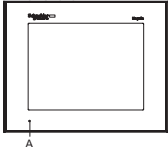
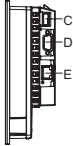
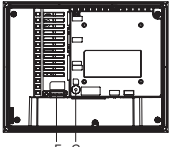
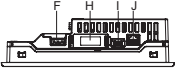
<p>Frontseite</p>	<p>HMIGTO3510</p>  <p>HMIGTO4310</p> 
<p>Rechts</p>	
<p>Rückseite</p>	
<p>Unterseite</p>	



A: Status-LED (siehe Seite 91)

B: Funktionsschalter

C: USB-Schnittstelle (Typ A)

- D: Serielle Schnittstelle (COM1)
- E: Serielle Schnittstelle (COM2) (siehe Seite 91)
- F: Netzverbinder
- G: SD-Kartenzugriffs-LED (siehe Seite 91)
- H: SD-Karten-Schnittstellenabdeckung/Ersatzakkufachabdeckung
- I: USB-Schnittstelle (mini-B)
- J: Ethernetschnittstelle (siehe Seite 91)

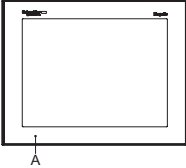
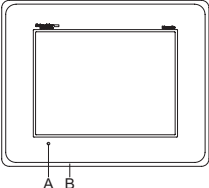
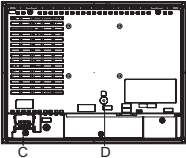
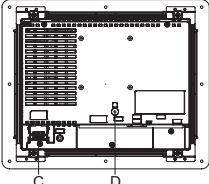
4. HMIGTO5310/5315

	HMIGTO5310	HMIGTO5315
Frontseite		
Rückseite		
Unterseite		

- A: Status-LED (siehe Seite 91)
- B: Edelstahlfassung
- C: Netzverbinder
- D: SD-Kartenzugriffs-LED (siehe Seite 91)
- E: Ethernetschnittstelle (siehe Seite 91)
- F: USB-Schnittstelle (mini-B)



G: SD-Karten-Schnittstellenabdeckung/Ersatzakkufachabdeckung

H: Serielle Schnittstelle (COM2) (siehe Seite 91)

I: Serielle Schnittstelle (COM1)

J: USB-Schnittstelle (Typ A)

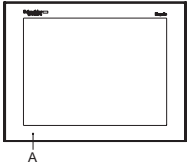
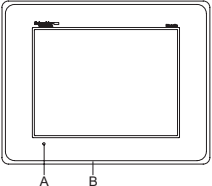
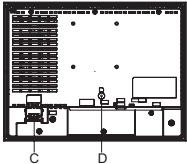
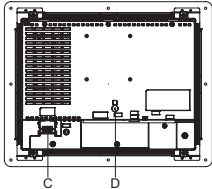
5. HMIGTO6310/6315

	HMIGTO6310	HMIGTO6315
Frontseite		
Rückseite		
Unterseite		

A: Status-LED (siehe Seite 91)

B: Edelstahlfassung

C: Netzverbinder

D: SD-Kartenzugriffs-LED (siehe Seite 91)

E: Ethernetschnittstelle (siehe Seite 91)

F: USB-Schnittstelle (mini-B)

G: SD-Karten-Schnittstellenabdeckung/Ersatzakkufachabdeckung

H: Serielle Schnittstelle (COM2) (siehe Seite 91)

I: Serielle Schnittstelle (COM1)

J: USB-Schnittstelle (Typ A)

6. LED-Anzeigen

(1) Status-LED

Farbe	Anzeige	Beschreibung
Grün	EIN	Offline.
		In Betrieb.
Orange	Blinken	Software wird gestartet.
Rot	EIN	Gerät wird eingeschaltet.
–	AUS	Gerät wird ausgeschaltet.

(2) SD-Kartenzugriffs-LED

Farbe	Anzeige	Beschreibung
Grün (Aktiv)	EIN	Die SD-Karte wird eingeführt.
	AUS	Die SD-Karte ist nicht eingesteckt, oder es wird nicht auf die CF-Karte zugegriffen.

(3) Ethernet-LED

	Farbe	Anzeige	Beschreibung
Verbindung  Aktiv	Grün (Aktiv)	Blinken	Es findet eine Datenübertragung statt.
		AUS	Keine Datenübertragung
	Grün (Link)	EIN	Datenübertragung ist in 10BASE-T/100BASE-TX verfügbar.
		AUS	Keine Verbindung oder Übertragung NICHT möglich.

(4) COM2-LED

Farbe	Anzeige	Beschreibung
Gelb	EIN	Kommunikation (Senden oder Empfangen von Daten) erfolgt.
	AUS	Keine Kommunikation.

Serielle Schnittstelle

Der serielle Port ist nicht potenzialgetrennt. Die Klemmen SG (Signalerde) und FG (Gehäuseerde) sind im Gerät miteinander verbunden.



ELEKTRISCHER SCHLAG

Wenn Sie mit der SG-Klemme ein externes Gerät mit dem Gerät verbinden, achten Sie bitte auf Folgendes:

- Stellen Sie sicher, dass es beim Einrichten des Systems nicht zum Kurzschluss kommt.
- Bei Verwendung eines 9-poligen D-Sub-Steckverbinders verbinden Sie die SG-Klemme Nr. 5 mit dem dezentralen Gerät, wenn der Host (SPS) nicht potenzialgetrennt ist. verbinden Sie die SG-Klemme Nr. 5 mit einer zuverlässigen Erdung, um das Risiko einer Schaltbeschädigung zu verringern.
- Bei Verwendung des RJ-45-Steckverbinders verbinden Sie die SG-Klemme Nr. 8 mit dem dezentralen Gerät, wenn der Host (SPS) nicht potenzialgetrennt ist. verbinden Sie die SG-Klemme Nr. 8 mit einer zuverlässigen Erdung, um das Risiko einer Schaltbeschädigung zu verringern.

Eine Missachtung dieser Anweisungen kann zum Tod führen oder schwere Verletzungen verursachen.



KOMMUNIKATIONVERLUST

- Die Kommunikationsports dürfen keiner übermäßigen Belastung ausgesetzt sein.
- Schließen Sie die Kommunikationskabel sicher an der Gerätewand oder am Schrank an.
- Verwenden Sie ausschließlich 9-polige RJ45-Kabel mit einem einwandfreien Verriegelungssystem.

Eine Missachtung dieser Anweisungen kann zu Verletzungen führen oder Schäden am Gerät verursachen.

1. Anschluss serielle Schnittstelle

Die Steckerbelegung der einzelnen seriellen Schnittstellen wird auf den entsprechenden Seiten beschrieben.

	COM1	COM2
HMIGTO1300	RS-232C (siehe Seite 94)	RS-485 (siehe Seite 96)
HMIGTO1310	RS-232C/RS-485 (siehe Seite 95)	-
HMIGTO2300	RS-232C (siehe Seite 94)	RS-485 (siehe Seite 96)
HMIGTO2310	RS-232C (siehe Seite 94)	RS-485 (siehe Seite 96)
HMIGTO2315	RS-232C (siehe Seite 94)	RS-485 (siehe Seite 96)
HMIGTO3510	RS-232C (siehe Seite 94)	RS-485 (siehe Seite 96)
HMIGTO4310	RS-232C (siehe Seite 94)	RS-485 (siehe Seite 96)
HMIGTO5310	RS-232C (siehe Seite 94)	RS-485 (siehe Seite 96)
HMIGTO5315	RS-232C (siehe Seite 94)	RS-485 (siehe Seite 96)
HMIGTO6310	RS-232C (siehe Seite 94)	RS-485 (siehe Seite 96)
HMIGTO6315	RS-232C (siehe Seite 94)	RS-485 (siehe Seite 96)

2. RS-232C

9-poliger D-Sub-Steckverbinder per RS-232C-Kabel.

Steckerzahl	RS-232C		
	Signalname	Richtung	Bedeutung
1	CD	Eingang	Trägererkennung
2	RD(RXD)	Eingang	Empfang von Daten
3	SD(TXD)	Ausgang	Senden von Daten
4	ER(DTR)	Ausgang	Datenübertragungs- einrichtung bereit
5	SG	–	Signalmasse
6	DR(DSR)	Eingang	Datensatz bereit
7	RS(RTS)	Ausgang	Sendeanforderung
8	CS(CTS)	Eingang	Senden möglich
9	CI(RI)/VCC	Eingang/–	Aufgerufene Statusanzeige +5V±5% Ausgang 0,25A
Stecker	FG	–	Rahmenerdung (gemeinsam mit SG)

Sie können Stecker Nr. 9 zwischen RI und VCC per Software wechseln.

HINWEISE

GERÄTESCHADEN

Wenden Sie nur die Nennspannung an.

Eine Missachtung dieser Anweisungen kann Schäden am Gerät verursachen.

Interfit-Halterung ist #4-40 (UNC).

3. RS-232C/RS-485

RJ-45-Verbinder per RS-232C- oder RS-485-Kabel.

Hinweis: Bei der Einrichtung der RS-485-Kommunikation ist bei manchen Geräten laut Kabelplan möglicherweise klemmenseitige Polarisierung erforderlich. Die Klemme benötigt keine spezielle Vorbereitung, da sie die Polarisierung automatisch vornimmt.

Steckerzahl	RS-232C/RS-485		
	Signalname	Richtung	Bedeutung
1	RD(RXD)	Eingang	Empfangsdaten (RS-232C)
2	SD(TXD)	Ausgang	Sendedaten (RS-232C)
3	NC	–	–
4	D1	Eingang/ Ausgang	Übertragungsdaten (RS-485)
5	D0	Eingang/ Ausgang	Übertragungsdaten (RS-485)
6	RS(RTS)	Ausgang	Sendeanforderung
7	NC	–	–
8	SG	–	Signalmasse
Stecker	FG	–	Rahmenerdung (gemeinsam mit SG)

4. RS-485

RJ-45-Verbinder per RS-485-Kabel.

Hinweis: Bei der Einrichtung der RS-485-Kommunikation ist bei manchen Geräten laut Kabelplan möglicherweise klemmenseitige Polarisierung erforderlich. Die Klemme benötigt keine spezielle Vorbereitung, da sie die Polarisierung automatisch vornimmt.

Steckerzahl	RS-485		
	Signalname	Richtung	Bedeutung
1	NC	–	–
2	NC	–	–
3	NC	–	–
4	Leitung A	Eingang/ Ausgang	Übertragungsdaten (RS-485)
5	Leitung B	Eingang/ Ausgang	Übertragungsdaten (RS-485)
6	RS(RTS)	Ausgang	Sendeanforderung
7	NC	–	keine Verbindung
8	SG	–	Signalmasse

1. Installationsanforderungen

- Die Dicke der Gehäusewand sollte sich nach der erforderlichen Stärke richten: 1,6 mm (0,06 in.) bis 5 mm (0,2 in.).
- Vergewissern Sie sich, dass die Montageplatten- oder Schaltschrankoberfläche eben und in einwandfreiem Zustand ist und keine scharfen Kanten aufweist.
- Selbst wenn sich die Plattendicke innerhalb des empfohlenen Bereichs befindet, kann es je nach Gerätematerial, -größe und Montageort des Magelis GTO oder eines anderen Gerätes zu Verformungen kommen. Um einer solchen Verformung vorzubeugen, muss die Montageoberfläche möglicherweise verstärkt werden.
- Stellen Sie sicher, dass Umgebungstemperatur und Luftfeuchtigkeit innerhalb des vorgeschriebenen Bereichs liegen.

Umgebungstemperatur:

0 bis 50 °C (32 bis 122 °F): HMIGTO1300/1310, HMIGTO2300, HMIGTO3510.

0 bis 55 °C (32 bis 131 °F): HMIGTO2310/2315, HMIGTO4310, HMIGTO5310/5315, HMIGTO6310/6315.

Luftfeuchtigkeit: 10 bis 90 % r. F.; Feuchtkugeltemperatur: maximal 39 ° (102 °F).

Bei der Installation des Magelis GTO in einem Schaltschrank oder Gehäuse bezieht sich die Umgebungstemperatur auf die Temperatur im Schaltschrank oder Gehäuse.

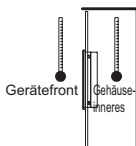

- Stellen Sie sicher, dass die Wärmeabgabe benachbarter Geräte nicht dazu führt, dass das Magelis GTO seine Standardbetriebstemperatur übersteigt.
- Bei vertikaler Montage des Magelis GTO sollte darauf geachtet werden, dass die rechte Seite des Geräts nach oben zeigt. Das bedeutet, der Netzanschluss des Gleichstrom-Modells sollte oben sein.

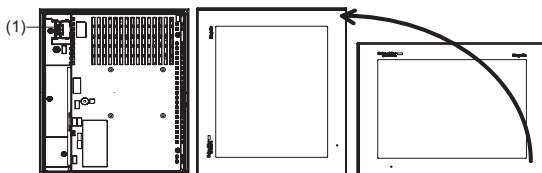

(1) Netzanschluss

- Bei Montage des Magelis GTO in schräger Position sollte die Vorderseite des Magelis GTO nicht mehr als 30° geneigt sein.

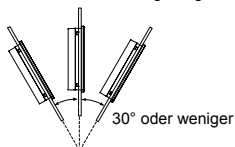

- Bei Montage des Magelis GTO in schräger Position mit einer Neigung von mehr als 30° darf die Umgebungstemperatur nicht höher sein als 40 °C (104 °F). Gegebenenfalls müssen Sie eine Gebläseluftkühlung (Ventilator, Klimaanlage) einsetzen, damit eine Umgebungsbetriebstemperatur von höchstens 40°C (104 F) gewährleistet ist.
- Um die Wartung und den Betrieb zu erleichtern und die Belüftung zu verbessern, sollte das Magelis GTO mindestens 100 mm (3,94 in.) von jeglichen benachbarten Strukturen und anderen Geräten entfernt installiert werden - siehe Abbildung unten.

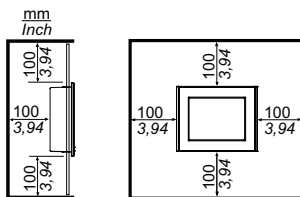

- Die Löcher auf der Rückseite des Magelis GTO (außer HMIGTO1300/1310) entsprechen nicht den VESA 75mm-Normen. Das Magelis GTO darf nicht an einen handelsüblichen VESA-Arm befestigt werden.

2. Montageschritte (außer HMIGTO2315/5315/6315)

HINWEISE

INSTABILITÄT BEI FEHLENDER ABSICHERUNG

Sorgen Sie beim Anbringen oder Entfernen der Halter für die Schraubmontage dafür, dass das Magelis GTO im Ausschnitt stabil ist.

Eine Missachtung dieser Anweisungen kann Schäden am Gerät verursachen.

Schritt	Aktion
1	Legen Sie das Magelis GTO mit der Anzeige nach unten auf eine saubere, ebene Oberfläche.
2	Überprüfen Sie, dass die Dichtung des Magelis GTO sicher in der dafür vorgesehenen Nut sitzt, die um den Rahmen des Geräts verläuft. Hinweis: Es wird dringend empfohlen, die Montagedichtung zu verwenden, da sie neben ihrer Wasser-abweisenden Wirkung auch Vibrationen absorbiert. Informationen zum Ersetzen der Montagedichtung erhalten Sie im "Magelis-GTO-Benutzerhandbuch".

- 3 Machen Sie einen Ausschnitt in der Montageplatte, und setzen Sie dann das Magelis GTO von vorne in den Ausschnitt.

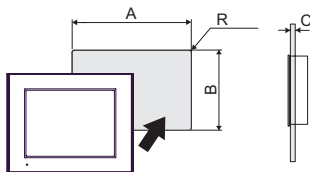

HMIGTO1300/1310

A	B	C	R
118,5 ⁺¹ ₋₀ mm (4,67 ^{+0.04} ₋₀ in.)	92,5 ⁺¹ ₋₀ mm (3,64 ^{+0.04} ₋₀ in.)	1,6...5 mm (0,06...0,2 in)	3 mm (0,12 in.) maximal

HMIGTO2300/2310

A	B	C	R
156 ⁺¹ ₋₀ mm (6,14 ^{+0.04} ₋₀ in.)	123,5 ⁺¹ ₋₀ mm (4,86 ^{+0.04} ₋₀ in.)	1,6...5 mm (0,06...0,2 in)	3 mm (0,12 in.) maximal

HMIGTO3510/HMIGTO4310

A	B	C	R
204,5 ⁺¹ ₋₀ mm (8,05 ^{+0.04} ₋₀ in.)	159,5 ⁺¹ ₋₀ mm (6,28 ^{+0.04} ₋₀ in.)	1,6...5 mm (0,06...0,2 in)	3 mm (0,12 in.) maximal

HMIGTO5310

A	B	C	R
259 ⁺¹ ₋₀ mm (10,2 ^{+0.04} ₋₀ in.)	201 ⁺¹ ₋₀ mm (7,91 ^{+0.04} ₋₀ in.)	1,6...5 mm (0,06...0,2 in)	3 mm (0,12 in.) maximal

HMIGTO6310

A	B	C	R
301,5 ⁺¹ ₋₀ mm (11,87 ^{+0.04} ₋₀ in.)	227,5 ⁺¹ ₋₀ mm (8,96 ^{+0.04} ₋₀ in.)	1,6...5 mm (0,06...0,2 in)	3 mm (0,12 in.) maximal

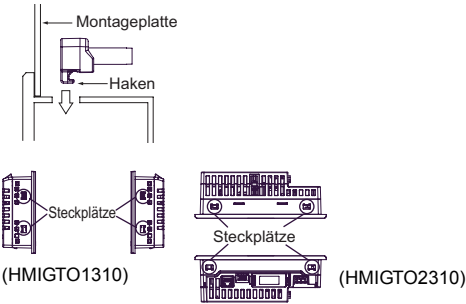
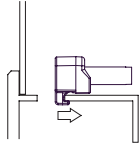
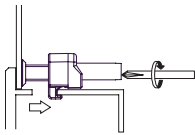
4	<p>Setzen Sie die Montagebefestigungen in die Einschübe des Magelis GTO oben und unten (links und rechts bei HMIGTO1300/1310) ein. Wenn die Befestigungen nicht ordnungsgemäß angebracht sind, kann das Magelis GTO verrutschen oder herausfallen.</p>  <p>Montageplatte</p> <p>Haken</p> <p>Steckplätze</p> <p>(HMIGTO1310)</p> <p>Steckplätze</p> <p>(HMIGTO2310)</p>
5	<p>Schieben Sie die Befestigungen nach hinten.</p> 
6	<p>Verwenden Sie einen Schraubendreher, um alle Befestigungsschrauben anzuziehen und das Magelis GTO auf diese Weise sicher in seiner Position zu montieren. Das erforderliche Anzugsdrehmoment beträgt 0,5 Nm (4,4 lb-in).</p> 

HINWEISE

GEHÄUSEBRUCH

- Ziehen Sie die Befestigungsschrauben mit einem Anzugsdrehmoment von maximal 0,5 Nm (4,4 in-lb) fest.
- Zur Verwendung auf flacher Oberfläche eines Gehäuses vom Typ 1, Typ 4X (nur Innenbereich) oder Typ 13.

Eine Missachtung dieser Anweisungen kann Schäden am Gerät verursachen.

3. Schritte zur Demontage (außer HMIGTO2315/5315/6315)

Schritt	Aktion
1	Lockern Sie die Montagebefestigungen (4) vom Magelis GTO.
2	Entfernen Sie das Magelis GTO langsam aus dem Montageplatte, während Sie die Überstände auf der Oberseite des Magelis GTO gedrückt halten. <div data-bbox="357 331 692 647" data-label="Image"> <p>(1) Überstände</p> </div> <p>Hinweis:</p> <ul style="list-style-type: none"> • Das Magelis GTO könnte beim Versuch, es ohne Eindrücken der Überstände zu entfernen, beschädigt werden. • Achten Sie darauf, dass Ihre Finger beim Eindrücken der Überstände nicht eingeklemmt werden.

▲ VORSICHT

VERLETZUNGSGEFAHR

Lassen Sie das Magelis GTO beim Entfernen aus der Montageplatte nicht fallen.

- Halten Sie das Magelis GTO in seiner Position fest, nachdem Sie die Befestigungen entfernt haben.
- Verwenden Sie dazu beide Hände.

Eine Missachtung dieser Anweisungen kann zu Verletzungen führen oder Schäden am Gerät verursachen.

4. Montageschritte (HMIGTO2315/5315/6315)

VORSICHT

VERLETZUNGSGEFAHR

Lassen Sie das Magelis GTO beim Entfernen aus der Montageplatte nicht fallen.

- Halten Sie das Magelis GTO in seiner Position fest, nachdem Sie die M4-Muttern und die Befestigungen entfernt haben.
- Verwenden Sie dazu beide Hände.

Eine Missachtung dieser Anweisungen kann zu Verletzungen führen oder Schäden am Gerät verursachen.

HINWEISE

INSTABILITÄT BEI FEHLENDER ABSICHERUNG

Sorgen Sie beim Anbringen oder Entfernen der M4-Sechskantmutter und Befestigungen dafür, dass das Magelis GTO im Ausschnitt stabil ist.

Eine Missachtung dieser Anweisungen kann Schäden am Gerät verursachen.

Schritt	Aktion
1	Legen Sie das Magelis GTO mit der Anzeige nach unten auf eine saubere, ebene Oberfläche.
2	Vergewissern Sie sich, dass die Dichtung des Magelis GTO richtig auf der Rückseite des magelis GTO sitzt.

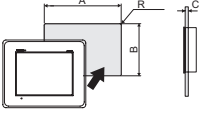
Schritt	Aktion																								
3	<p>Machen Sie einen Ausschnitt in der Montageplatte, und setzen Sie dann das Magelis GTO von vorne in den Ausschnitt.</p>  <p>HMIGTO2315</p> <table border="1"> <thead> <tr> <th>A</th> <th>B</th> <th>C</th> <th>R</th> </tr> </thead> <tbody> <tr> <td>195⁺¹₋₀ mm (7,68^{+0.04}₋₀ in.)</td> <td>162,5⁺¹₋₀ mm (6,40^{+0.04}₋₀ in.)</td> <td>1,6...5 mm (0,06...0,2 in)</td> <td>3 mm (0,12 in.) maximal</td> </tr> </tbody> </table> <p>HMIGTO5315</p> <table border="1"> <thead> <tr> <th>A</th> <th>B</th> <th>C</th> <th>R</th> </tr> </thead> <tbody> <tr> <td>298⁺¹₋₀ mm (11,73^{+0.04}₋₀ in.)</td> <td>240⁺¹₋₀ mm (9,45^{+0.04}₋₀ in.)</td> <td>1,6...5 mm (0,06...0,2 in)</td> <td>3 mm (0,12 in.) maximal</td> </tr> </tbody> </table> <p>HMIGTO6315</p> <table border="1"> <thead> <tr> <th>A</th> <th>B</th> <th>C</th> <th>R</th> </tr> </thead> <tbody> <tr> <td>340,5⁺¹₋₀ mm (13,41^{+0.04}₋₀ in.)</td> <td>266,5⁺¹₋₀ mm (10,49^{+0.04}₋₀ in.)</td> <td>1,6...5 mm (0,06...0,2 in)</td> <td>3 mm (0,12 in.) maximal</td> </tr> </tbody> </table>	A	B	C	R	195 ⁺¹ ₋₀ mm (7,68 ^{+0.04} ₋₀ in.)	162,5 ⁺¹ ₋₀ mm (6,40 ^{+0.04} ₋₀ in.)	1,6...5 mm (0,06...0,2 in)	3 mm (0,12 in.) maximal	A	B	C	R	298 ⁺¹ ₋₀ mm (11,73 ^{+0.04} ₋₀ in.)	240 ⁺¹ ₋₀ mm (9,45 ^{+0.04} ₋₀ in.)	1,6...5 mm (0,06...0,2 in)	3 mm (0,12 in.) maximal	A	B	C	R	340,5 ⁺¹ ₋₀ mm (13,41 ^{+0.04} ₋₀ in.)	266,5 ⁺¹ ₋₀ mm (10,49 ^{+0.04} ₋₀ in.)	1,6...5 mm (0,06...0,2 in)	3 mm (0,12 in.) maximal
A	B	C	R																						
195 ⁺¹ ₋₀ mm (7,68 ^{+0.04} ₋₀ in.)	162,5 ⁺¹ ₋₀ mm (6,40 ^{+0.04} ₋₀ in.)	1,6...5 mm (0,06...0,2 in)	3 mm (0,12 in.) maximal																						
A	B	C	R																						
298 ⁺¹ ₋₀ mm (11,73 ^{+0.04} ₋₀ in.)	240 ⁺¹ ₋₀ mm (9,45 ^{+0.04} ₋₀ in.)	1,6...5 mm (0,06...0,2 in)	3 mm (0,12 in.) maximal																						
A	B	C	R																						
340,5 ⁺¹ ₋₀ mm (13,41 ^{+0.04} ₋₀ in.)	266,5 ⁺¹ ₋₀ mm (10,49 ^{+0.04} ₋₀ in.)	1,6...5 mm (0,06...0,2 in)	3 mm (0,12 in.) maximal																						

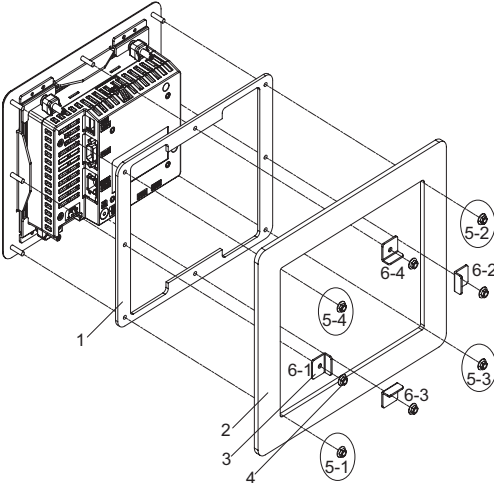
Schritt	Aktion
4	<p>Setzen Sie das Magelis GTO in den Montageausschnitt ein.</p>  <p>1 Montagedichtung 2 Montageplatte 3 Halterungen 4 M4-Sechskantmuttern 5 Bitte lesen Sie Schritt 5. 6 Bitte lesen Sie Schritt 6.</p>
5	<p>Befestigen Sie die vier Ecken der Rückseite des Magelis GTO durch Anziehen der M4-Sechskantmuttern in der im Beispiel von Schritt 4 dargestellten Reihenfolge. Verwenden Sie einen Steckschlüssel, um die einzelnen M4-Sechskantmuttern anzuziehen und Magelis GTO in seiner Position zu sichern. Das erforderliche Anzugsdrehmoment beträgt 0,5 Nm (4,4 lb-in). Wenn die M4-Sechskantmuttern nicht ordnungsgemäß angebracht sind, kann das Magelis GTO verrutschen oder herausfallen.</p>

Schritt	Aktion
6	<p>Bringen Sie die Halterung in der im Beispiel von Schritt 4 dargestellten Reihenfolge in der Mitte zwischen die M4-Sechskantmuttern auf.</p> <p>Verwenden Sie einen Steckschlüssel, um die einzelnen M4-Sechskantmuttern anzuziehen und Magelis GTO in seiner Position zu sichern. Das erforderliche Anzugsdrehmoment beträgt 0,5 Nm (4,4 lb-in). Wenn die M4-Sechskantmuttern nicht ordnungsgemäß angebracht sind, kann das Magelis GTO verrutschen oder herausfallen.</p>
7	<p>Ziehen Sie alle M4-Sechskantmuttern erneut an. Das erforderliche Anzugsdrehmoment beträgt 0,5 Nm (4,4 lb-in).</p> <p>Hinweis: Die unten mit Vierecken gekennzeichneten Montagebefestigungen dürfen nicht gelockert werden.</p> <div data-bbox="238 546 564 829" style="text-align: center;"> <p>(1)</p> </div> <p>1 Montageplatte</p>

HINWEISE

GEHÄUSEBRUCH

- Der Anzugsdrehmoment der Schrauben darf 0,5 Nm (4,4 in-lb) nicht überschreiten.
- Zur Verwendung auf flacher Oberfläche eines Gehäuses vom Typ 1, Typ 4X (nur Innenbereich) oder Typ 13.

Eine Missachtung dieser Anweisungen kann Schäden am Gerät verursachen.

WARNHINWEIS

ÜBERMÄSSIGE ELEKTROMAGNETISCHE INTERFERENZEN

- Wenn die Gehäuseerdeklammer (FG) angeschlossen ist, vergewissern Sie sich, dass der Draht geerdet ist. Eine fehlende Erdung führt zu übermäßigen elektromagnetischen Interferenzen (EMI). Eine Erdung ist erforderlich, um die Anforderungen an elektromagnetische Verträglichkeit (EMV) zu erfüllen.
- Entfernen Sie das Gerät von jeglicher Stromzufuhr, bevor Sie Bestandteile des Systems entfernen und vor der Montage oder Entfernung von Zubehör, Hardware oder Kabeln.
- Unterbrechen Sie die Stromzufuhr vor der Verkabelung an die Netzklemmen des Magelis GTO ab.
- Das Gleichstromgerät (DC) verwendet nur 24 V DC. Die Verwendung eines anderen Leistungspegels kann zur Beschädigung sowohl der Stromversorgung als auch des Magelis GTO führen.
- Da das Magelis GTO nicht mit einem Ein/Aus-Schalter ausgestattet ist, ist ein Leistungsschalter an die Stromversorgung des Geräts anzuschließen.
- Vergewissern Sie sich, dass die Gehäuseerdeklammer des Magelis GTO geerdet ist.
- Ersetzen und sichern Sie alle Systembestandteile, bevor Sie die Stromzufuhr für das Magelis GTO einschalten.

Eine Missachtung dieser Anweisungen kann zu Tod, schweren Verletzungen oder Geräteschaden führen.

Hinweis: Die Klemmen für Signallerde (SG) und Gehäuseerde (FG) sind im Magelis GTO miteinander verbunden.

Anschließen des Gleichstrom-Netzkabels

Verwenden Sie ausschließlich Kupferleiter.

Temperaturbelastung feldinstallierter Leiter: 75°C (167 °F).

Stromkabel-Durchmesser	0,75 bis 2,5 mm ² (18-13 AWG)
Leitertyp	Einfacher oder verseilter Draht*1
Leiterlänge	

*1 Wenn die (einzelnen) Enddrähte des Leiters nicht richtig verdreht sind, kann ein Kurzschluss zwischen den Enddrähten oder ein Kurzschluss zwischen einem Enddraht und einer Elektrode entstehen.

Netzanschluss-Spezifikationen

HMIGTO1300/1310 /
HMIGTO2300/2310/2315 /
HMIGTO3510/4310

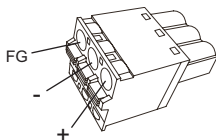

HMIGTO5310/5315 /
HMIGTO6310/6315

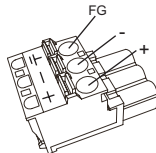

Verbindung	Draht
+	24 V DC
-	0 V DC
FG	Am Gehäuse des Geräts angeschlossene, geerdete Klemme.

Anschluss des Gleichstromkabels

Schritt	Aktion
1	Stellen Sie sicher, dass das Stromkabel nicht an das Stromnetz angeschlossen ist.
2	Überprüfen Sie die Nennspannung, und entfernen Sie den "DC24V"-Aufkleber vom Gleichstrom-Steckverbinder.
3	Entfernen Sie 10 mm (0,39 in.) der Vinylmembran von den Enden der Stromkabeldrähte. <div style="text-align: center;"> </div>
4	Wenn Sie einen vorseilten Draht verwenden, verdrehen Sie die Enden. Ein Verzinnen der Drahtenden durch Löten verringert das Risiko des Ausfransens und gewährleistet eine gute elektrische Übertragung.
5	Drücken Sie den Öffnungsknopf mit einem kleinen, flachen Schraubenzieher, um das gewünschte Steckloch zu öffnen.
6	Führen Sie die einzelnen Klemmstecker in ihre jeweiligen Halter ein. Lassen Sie den Öffnungsknopf los, um den Stecker festzuklemmen. HMIGTO1300/1310 / HMIGTO2300/ 2310/2315 / HMIGTO3510 / HMIGTO4310 HMIGTO5310/5315 / HMIGTO6310/6315 <div style="display: flex; justify-content: space-around; align-items: flex-start; margin-top: 10px;"> <div style="text-align: center;"> <p>Gleichstromnetz-kabel</p> </div> <div style="text-align: center;"> <p>Öffnungsknopf</p> </div> <div style="text-align: center;"> <p>Öffnungsknopf</p> </div> </div>
7	Wenn alle drei Stecker eingeführt sind, führen Sie den Gleichstrom-Steckverbinder in den Netzanschluss des Magelis GTO.

Hinweis:

- Löten Sie den Draht nicht direkt am Stromaufnahme-Pin fest.
- Um die Möglichkeit eines Klemmenkurzschlusses zu vermeiden, vermeiden Sie Steckklemmen mit Isolierummantelung

- Sie können den Gleichstrom-Steckverbinder für HMIGTO1300/1310, HMIGTO2300/2310/2315, HMIGTO3510 oder HMIGTO4310 an HMIGTO5310/5315 oder HMIGTO6310/6315 anschließen. Die umgekehrte Möglichkeit besteht jedoch nicht. Sie können den Gleichstrom-Steckverbinder für HMIGTO5310/5315 oder HMIGTO6310/6315 nicht an HMIGTO1300/1310, HMIGTO2300/2310/2315, HMIGTO3510 oder HMIGTO4310 anschließen.

Vorsichtsmaßnahmen Kabelverbindungen

Verbesserung des Rausch-/Stoßspannungswiderstands

- Das Netzkabel des Magelis GTO sollte nicht gemeinsam mit bzw. in unmittelbarer Nähe von Hauptstromleitungen (hohe Spannung, hoher Strom), Stromleitungen oder Ein-/Ausgangsleitungen verlegt werden. Außerdem sollten ihre verschiedenen Systeme auseinander gehalten werden. Wenn Stromleitungen nicht über ein separates System verkabelt werden können, sollten für Ein-/Ausgangsleitungen abgeschirmte Kabel verwendet werden.
- Die Stromkabel sollten so kurz wie möglich gehalten werden; außerdem sollten die Kabelenden kurz vor dem Netzgerät verdrillt werden (paarweise verdrillte Kabel - Twisted-Pair-Kabel).
- Besteht in der Stromleitung ein übermäßiges Rauschen, schließen Sie vor dem Einschalten der Stromzufuhr einen rauschvermindernden Transistor an.
- Schließen Sie einen Überspannungsschutz an, um Spannungsschöße auszugleichen. Erden Sie den Überspannungsschutz (E1) separat vom Magelis GTO (E2).

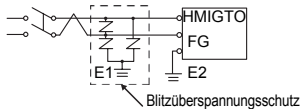

Vermeiden von Kurzschlüssen

- Die Klemmen für Signalerde (SG) und Gehäuseerde (FG) sind im Magelis GTO miteinander verbunden. Stellen Sie bei der Verbindung der SG-Leitung mit einem anderen Gerät sicher, dass es nicht zu Kurzschlüssen kommt.

Erdung

- Verwenden Sie einen speziellen Erdungsdraht mit einem Erdungswiderstand von 100Ω oder weniger und einen Draht von 2 mm^2 (AWG 14) oder dicker bzw. der der Norm Ihres Landes entspricht.

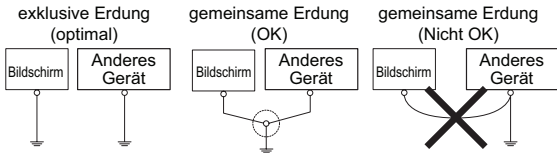

USB-Kabelklemme

Bringen Sie bei Verwendung eines USB-Geräts eine USB-Kabelklemme an die USB-Schnittstelle an, damit sich das USB-Kabel nicht löst.

⚠ WARNHINWEIS

EXPLOSIONSGEFAHR IN GEFAHRENBEREICHEN

- Stellen Sie sicher, dass die Strom- und Ein-/Ausgangsverkabelung (E/A) den Verkabelungsmethoden der Klasse I, Division 2 entspricht.
- Wechseln Sie keine Komponenten aus, die die Konformität mit Klasse I, Division 2 beeinträchtigen können.
- Überprüfen Sie vor Verwendung der USB-Schnittstelle, ob das USB-Kabel mit der USB-Kabelklemme befestigt wurde.
- Trennen Sie die Stromversorgung, bevor Sie Steckverbinder an das Gerät anschließen oder vom Gerät lösen.

Eine Missachtung dieser Anweisungen kann zu Tod, schweren Verletzungen oder Geräteschaden führen.

1. Anschluss der USB-Typ-A-Kabelklemme

Hinweis: Achten Sie auf Ihre Finger. Der Rand der Klemme ist scharf.

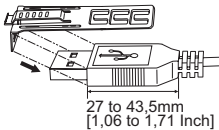
Schritt	Aktion
1	<p>Montieren Sie die Klemme auf das Steckergehäuse mit der USB-Kennzeichnung , so dass sie übersteht. Die Klemme entspricht der Länge von 27 bis 43,5 mm [1,06 bis 1,71 inch] des USB-Steckers.</p>  <p>27 to 43,5mm [1,06 to 1,71 Inch]</p>

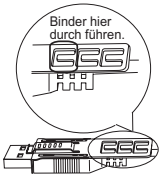
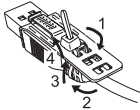
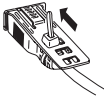
2	<p>Justieren Sie die Klemme mit dem USB-Kabelsteckergehäuse. Justieren Sie die Position der Löcher, wo die Klemme befestigt ist. Wählen Sie zur Stabilität die Klemmen-Loch-Position, die dem Steg des Steckergehäuses am nächsten ist.</p> 
3	<p>Führen Sie den Binder gemäß Abbildung durch das Klemmenloch. Machen Sie mit dem Binder nun eine Schlaufe, und führen Sie ihn durch das Kopfstück, so dass das USB-Kabel durch die Mitte der Binderschleufe passt. Der Klip ist nun mit dem USB-Kabel befestigt.</p>  <p>Hinweis:</p> <ul style="list-style-type: none">• Überprüfen Sie vorher die Richtung des Kopfstücks. Stellen Sie sicher, dass das USB-Kabel durch die Binderschleufe ist, und dass der Binder durch das Kopfstück geführt werden kann.• Diese Binder sind als Sammelpäckchen verpackt oder handelsüblich mit einer Breite von 4,8 mm [0,19 inch] und einer Dicke von 1,3 mm [0,05 inch] erhältlich.
4	<p>Während Sie den Griff an der Klemme gedrückt halten, führen Sie das Kabel von Schritt 3 ganz in die USB-Host-Schnittstelle ein. Stellen Sie sicher, dass die Klemmschleufe sich sicher am USB-Kabel befindet, das an das Magelis GTO angeschlossen ist.</p> 

2. Entfernen des USB-Typ-A-Kabels

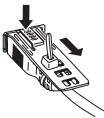
Schritt	Aktion
1	Entfernen Sie das USB-Kabel, während Sie den Griffbereich der Klemme drücken. 

3. Anschluss der USB-mini-B-Kabelklemme

Hinweis: Achten Sie auf Ihre Finger. Der Rand der Klemme ist scharf.

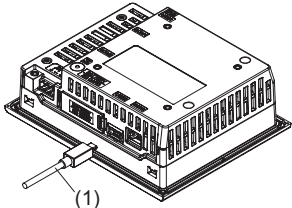
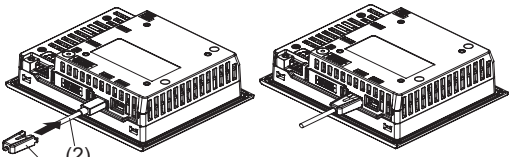
Schritt	Aktion
1	Führen Sie das USB-Kabel in die USB-Schnittstelle (mini-B) ein. 
2	Bringen Sie den USB-Halter an, um das USB-Kabel zu befestigen. Führen Sie die USB-Halterung in die USB-Schnittstelle (mini-B) ein. 

4. Entfernen des USB-Halters

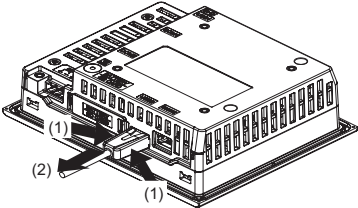
Schritt	Aktion
1	Entfernen Sie den USB-Halter durch seitliches Drücken der Schlaufe.  <p>Das Diagramm zeigt eine Draufsicht auf eine USB-Kabelklemme. Ein USB-Kabel (2) ist in den Anschluss eingesteckt. Ein USB-Halter (1) ist an der Seite des Kabels befestigt. Ein Pfeil (1) zeigt auf die Schlaufe des Halters, die seitlich gedrückt werden soll, um das Kabel zu entfernen. Ein weiterer Pfeil (1) zeigt auf den USB-Halter selbst.</p>

1 USB-Halterung
2 USB-Kabel

Normen

Relevante Normen

Die Registrierungsmodell-Nr. ist wie folgt:

- HMIGTO1300
- HMIGTO1310
- HMIGTO2300
- HMIGTO2310
- HMIGTO2315
- HMIGTO3510
- HMIGTO4310
- HMIGTO5310
- HMIGTO5315
- HMIGTO6310
- HMIGTO6315

Die Herstellung des Magelis GTO erfolgte gemäß:

- Standard UL 508 und CSA C22.2 n°142 für industrielle Steuerungsgeräte

Hinweis:

- Für die Verwendung in einer Umgebung gemäß Verschmutzungsgrad 2 geeignet.
 - Zur Verwendung auf flacher Oberfläche eines Gehäuses vom Typ 1, Typ 4X (nur Innenbereich) oder Typ 13.
 - 24V DC-Eingangseinheit muss mit einer Stromversorgung der Klasse 2 verwendet werden.
 - Nur zur Verwendung in Gefahrenbereichen der Klasse 1, Division 2.
- Standard ANSI/ISA - 12.12.01 und CSA C22.2 n°213 für elektrische Anlagen zum Einsatz in Gefahrenbereichen der Klassen I, Division 2
 - GOST-Zertifizierung.
Weitere Informationen siehe Produktkennzeichnungen.
 - ATEX-Zertifizierung durch den Technischen Überwachungsverein.
Weitere Informationen siehe Produktbeschriftung.
 - Handelsmarinevorschriften. (Ausnahme: Magelis GTOxxx5.)
Die Produkte sind für die Entsprechung der Handelsmarinevorschriften konzipiert.
Informationen zu den Montagerichtlinien der Handelsmarinevorschriften erhalten Sie auf der Website von Schneider Electric.
 - Standard EN1672-2 (Magelis GTOxxx5).
 - FDA-Regulierung 21 CFR 177 (Magelis GTOxxx5).

WARNHINWEIS

EXPLOSIONSGEFAHR IN GEFAHRENBEREICHEN

- Stellen Sie sicher, dass die Strom- und Ein-/Ausgangsverkabelung (E/A) den Verkabelungsmethoden der Klasse I, Division 2 entspricht.
- Wechseln Sie keine Komponenten aus, die die Konformität mit Klasse I, Division 2 beeinträchtigen können.
- Schließen Sie Geräte nur an bzw. trennen Sie Anschlüsse von Geräten nur, wenn Sie das Gerät zuvor von der Stromversorgung getrennt haben oder wenn im betreffenden Bereich keine Gefahr besteht.
- Nicht während der Stromzufuhr ausstecken.
- Verriegeln Sie extern angeschlossene Geräte und jede Schnittstelle, bevor Sie die Stromzufuhr einschalten.
- USB-Kabel nur verwenden, anschließen oder trennen, wenn im Bereich bekanntlich keine Gefahr besteht.
- Potentielle Gefahr elektrostatischer Aufladung: Wischen Sie die Frontseite des Geräts vor dem Einschalten mit einem feuchten Tuch ab.

Eine Missachtung dieser Anweisungen kann zu Tod, schweren Verletzungen oder Geräteschaden führen.

VORSICHT

UMWELTGEFAHREN FÜR DAS GERÄT

- Das Gerät darf die Umgebungstemperatur erreichen und dabei folgende Werte vor dem Einschalten nicht überschreiten:
50°C (122°F): HMIGTO1300/1310, HMIGTO2300, HMIGTO3510.
55°C (131°F): HMIGTO2310/2315, HMIGTO4310, HMIGTO5310/5315 und HMIGTO6310/HMIGTO6315.
- Schalten Sie das Gerät nicht ein, wenn es im Inneren zu Kondensation kam. Nach völligem Trocknen darf das Gerät eingeschaltet werden.
- Setzen Sie das Gerät nicht direktem Sonnenlicht aus.
- Die Belüftung im Gerätegehäuse darf nicht blockiert werden.
- Entstauben Sie das Gerät vor dem Einschalten.
- Stellen Sie sicher, dass die Kabelmontagebefestigungen nicht beschädigt sind. Ersetzen Sie sie gegebenenfalls.
- Der Hauptakku darf nur von qualifiziertem Personal ausgewechselt werden.
- Montieren Sie das Gerät in einem Gehäuse, das der Schutzstufe IP54 für Kategorie 3G und IP6X für Kategorie 3D entspricht sowie den Anforderungen bzgl. Kategorien 3G oder 3D in Zonen 2/22 (Kategorie 3: normale Schutzstufe - G: Gas - D: Staub).

Eine Missachtung dieser Anweisungen kann zu Verletzungen führen oder Schäden am Gerät verursachen.

Die Montage, Verwendung und Wartung des Magelis GTO muss erfolgen gemäß:

- Standard WEEE, Richtlinie 2002/96/EC
- Standard RoHS, Richtlinie 2002/95/EC
- Standard RoHS China, Standard SJ/T 11363-2006

Tabla de materias

Generalidades

Contenido del paquete	122
-----------------------------	-----

Especificaciones eléctricas

1. HMIGTO1300/1310/2300/2310/2315/3510/4310	123
2. HMIGTO5310/5315/6310/6315	124

Números de referencia y funciones

1. HMIGTO1300/1310	125
2. HMIGTO2300/2310/2315	126
3. HMIGTO3510/4310	128
4. HMIGTO5310/5315	129
5. HMIGTO6310/6315	130
6. Indicaciones del LED	131

Interface

1. Conexión para la interface serie	133
2. RS-232C	134
3. RS-232C/RS-485	135
4. RS-485	136

Instalación

1. Requisitos de instalación	137
2. Procedimiento de instalación (excepto HMIGTO2315/5315/6315)	139
3. Procedimiento de remoción (excepto HMIGTO2315/5315/6315)	143
4. Procedimiento de instalación (HMIGTO2315/5315/6315)	144

Cableado

Cableado	148
----------------	-----

Abrazadera del cable USB

1. Sujeción de la abrazadera de cable USB Tipo A:	153
2. Remoción del cable USB Tipo A	155
3. Sujeción de la abrazadera del cable USB mini B:	155
4. Remoción del soporte del USB	156

Normas

Normas pertinentes	157
--------------------------	-----

Contenido del paquete

Los siguientes ítems están incluidos en el paquete. Antes de utilizar la pantalla Magelis GTO, verifique que todos estos ítems estén presentes:

- 1 Magelis GTO: 1
- 2 Junta de instalación: 1 (unida al equipo de Magelis GTO)
- 3 Fijaciones de montaje: cuatro por conjunto
- 4 Soportes: 4
- 5 Tuercas hexagonales M4: 8
- 6 Conector de fuentes de alimentación CC: 1
- 7 Abrazadera del cable USB Tipo A: un conjunto (un clip y una brida de cables)
- 8 Abrazadera del cable USB mini B: una (un soporte de USB)
- 9 Guía de Referencia Rápida de Magelis GTO (la presente): 1

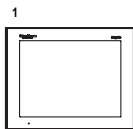

2
Para Magelis GTO excepto
HMIGTO2315/5315/6315



Para HMIGTO2315/5315/6315

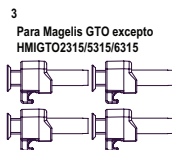
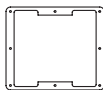

6
Para Magelis GTO excepto
HMIGTO5310/5315/6310/6315



Para HMIGTO5310/5315
Para HMIGTO6310/6315

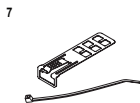

Este panel ha sido embalado cuidadosamente, prestando especial atención a la calidad.

No obstante, si descubre que falta algún elemento o que algo está dañado, contacte con su distribuidor local inmediatamente.

1. HMIGTO1300/1310/2300/2310/2315/3510/4310

Especificaciones		HMIGTO1300 HMIGTO1310	HMIGTO2300 HMIGTO2310 HMIGTO2315	HMIGTO3510 HMIGTO4310
Fuente de alimentación	Tensión de entrada nominal	24 Vcc		
	Límites de la tensión de entrada	19,2...28,8 Vcc		
	Caída de tensión	2 ms o menos	5 ms o menos	
	Consumo de alimentación	9,6W o menos	10,5W o menos	12W o menos
	Cuando no se suministra alimentación eléctrica a los dispositivos externos	5,2W o menos	6,5W o menos	8W o menos
	Retroiluminación apagada (Modo de espera)	4,2W o menos	4,5W o menos	5W o menos
	Retroiluminación atenuada (Brillo: 20%)	4,3W o menos	5W o menos	5,5W o menos
	Corriente de irrupción	30 A o menos		
	Resistencia de la tensión	1.000 Vca, 20 mA por un min (entre los bornes de carga y de la toma de tierra)		
	Resistencia de aislamiento	500 Vcc, 10 M Ω o mas (entre los bornes de carga y de la toma de tierra)		

2. HMIGTO5310/5315/6310/6315

Especificaciones		HMIGTO5310/HMIGTO5315/ HMIGTO6310/HMIGTO6315
Fuente de alimentación	Tensión de entrada nominal	24 Vcc
	Límites de la tensión de entrada	19,2...28,8 Vcc
	Caída de tensión	10 ms o menos
	Consumo de alimentación	17W o menos
	Cuando no se suministra alimentación eléctrica a los dispositivos externos	12W o menos
	Retroiluminación apagada (Modo de espera)	7W o menos
	Retroiluminación atenuada (Brillo: 20%)	8W o menos
Corriente de irrupción	30 A o menos	
Resistencia de la tensión	1.000 Vca, 20 mA por un min (entre los bornes de carga y de la toma de tierra)	
Resistencia de aislamiento	500 Vcc, 10 M Ω o mas (entre los bornes de carga y de la toma de tierra)	

1. HMIGTO1300/1310

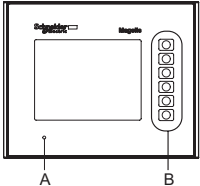
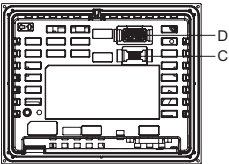
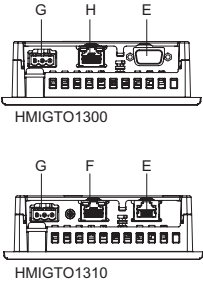
<p>Frontal</p>	
<p>Posterior</p>	
<p>Inferior</p>	 <p style="text-align: center;">HMIGTO1300</p> <p style="text-align: center;">HMIGTO1310</p>

- A: Indicador LED de estado (véase la página 131)
- B: Conmutadores de funciones
- C: Interface USB (mini-B)
- C: Interface USB (Tipo A)
- E: Interface serie (COM1)
- F: Interface Ethernet (véase la página 131)
- G: Conector de alimentación
- H: Interface serie (COM2)

Español

2. HMIGTO2300/2310/2315

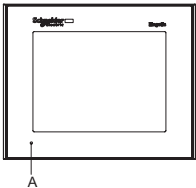
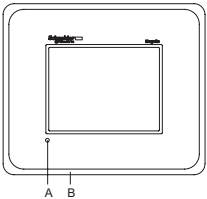
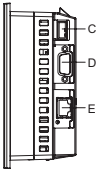
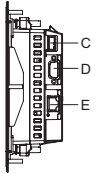
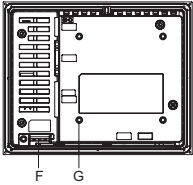
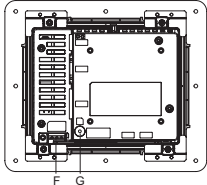
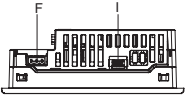
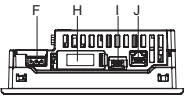
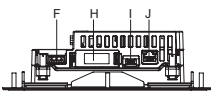
	HMIGTO2300/2310	HMIGTO2315
Frontal	 <p>A</p>	 <p>A B</p>
Derecha	 <p>C D E</p>	 <p>C D E</p>
Posterior	 <p>F G</p>	 <p>F G</p>
Inferior	 <p>HMIGTO2300</p>  <p>HMIGTO2310</p>	

- A: Indicador LED de estado (véase la página 131)
- B: Bisel de acero inoxidable
- C: Interface USB (Tipo A)
- D: Interface serie (COM1)
- E: Interface serie (COM2) (véase la página 131)
- F: Conector de alimentación
- G: Indicador LED de acceso a la tarjeta SD (véase la página 131)^{*1}
- H: Cubierta del interface de la tarjeta SD/Cubierta de la ranura de inserción de la batería de reemplazo^{*1}
- I: Interface USB (mini-B)
- J: Interface Ethernet (véase la página 131)

*1 Sólo para HMIGTO2310 y HMIGTO2315.

3. HMIGTO3510/4310

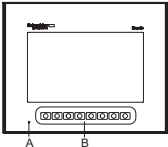
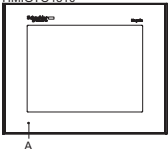
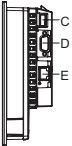
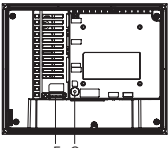
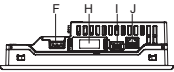
<p>Frontal</p>	<p>HMIGTO3510</p>  <p>HMIGTO4310</p> 
<p>Derecha</p>	
<p>Posterior</p>	
<p>Inferior</p>	



A: Indicador LED de estado (véase la página 131)

B: Conmutadores de funciones

C: Interface USB (Tipo A)

- D: Interface serie (COM1)
 E: Interface serie (COM2) (véase la página 131)
 F: Conector de alimentación
 G: Indicador LED de acceso a la tarjeta SD (véase la página 131)
 H: Cubierta del interface de la tarjeta SD/Cubierta de la ranura de inserción de la batería de reemplazo
 I: Interface USB (mini-B)
 J: Interface Ethernet (véase la página 131)

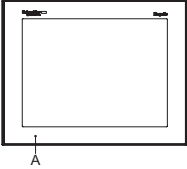
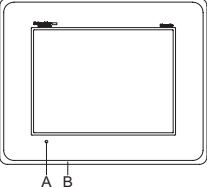
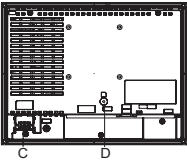
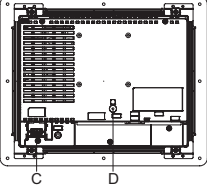
4. HMIGTO5310/5315

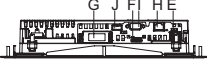
	HMIGTO5310	HMIGTO5315
Frontal		
Posterior		
Inferior		

- A: Indicador LED de estado (véase la página 131)
 B: Bisel de acero inoxidable
 C: Conector de alimentación
 D: Indicador LED de acceso a la tarjeta SD (véase la página 131)
 E: Interface Ethernet (véase la página 131)

F: Interface USB (mini-B)



G: Cubierta del interface de la tarjeta SD/Cubierta de la ranura de inserción de la batería de reemplazo

H: Interface serie (COM2)(véase la página 131)

I: Interface serie (COM1)

J: Interface USB (Tipo A)

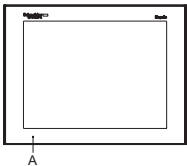
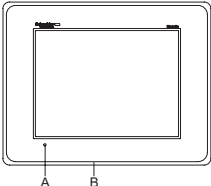
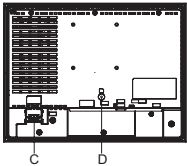
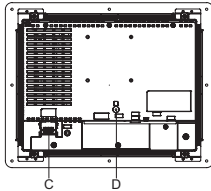
5. HMIGTO6310/6315

	HMIGTO6310	HMIGTO6315
Frontal		
Posterior		
Inferior		

A: Indicador LED de estado (véase la página 131)

B: Bisel de acero inoxidable

C: Conector de alimentación

D: Indicador LED de acceso a la tarjeta SD (véase la página 131)

E: Interface Ethernet (véase la página 131)

F: Interface USB (mini-B)

G: Cubierta del interface de la tarjeta SD/Cubierta de la ranura de inserción de la batería de reemplazo

H: Interface serie (COM2)(véase la página 131)

I: Interface serie (COM1)

J: Interface USB (Tipo A)

6. Indicaciones del LED

(1) Indicador LED de estado

Color	Indicador	Descripción
Verde	ON	Offline.
		En funcionamiento.
Naranja	Intermitencia	El software se está iniciando.
Rojo	ON	El equipo está encendido.
–	OFF	El equipo está apagado.

(2) Indicador LED de acceso a la tarjeta SD

Color	Indicador	Descripción
Verde (activo)	ON	La tarjeta SD está insertada.
	OFF	La tarjeta SD no está insertada o no se está obteniendo acceso a la misma.

(3) LED de Ethernet

	Color	Indicador	Descripción
 <p>Enlace Activo</p>	Verde (activo)	Intermitencia	Transmisión de datos en curso.
		OFF	Ninguna transmisión de datos
	Verde (vínculo)	ON	La transmisión de datos está disponible en 10BASE-T/100BASE-TX.
		OFF	No hay conexión o la transmisión posterior no está disponible.

(4) LED de COM2

Color	Indicador	Descripción
Amarillo	ON	Comunicación (envío o recepción de datos) en curso.
	OFF	Ninguna comunicación.

Interface serie

El puerto serie no está aislado. Los terminales SG (toma de tierra de señal) y FG (toma de tierra del bastidor) están conectados dentro del panel.



PELIGRO

DESCARGA ELÉCTRICA

Cuando use el borne de SG para conectar un dispositivo externo al panel:

- Confirme que no se haya creado un bucle de cortocircuito cuando instale el sistema.
- Cuando use el conector Sub-D de 9 pines, conecte el borne de SG #8 a un equipo remoto si la unidad base (PLC) no está aislada. Conecte el borne de SG #5 a una conexión a tierra conocida y fiable para reducir el riesgo de daños en el circuito.
- Cuando use el conector RJ-45, conecte el borne de SG #8 a un equipo remoto si la unidad base (PLC) no está aislada. Conecte el borne de SG #8 a una conexión a tierra conocida y fiable para reducir el riesgo de daños en el circuito.

Si no sigue estas instrucciones, provocará la muerte o serios daños personales.

⚠ PRECAUCIÓN

PÉRDIDA DE COMUNICACIÓN

- No someta los puertos de comunicación a una carga excesiva.
- Sujete con firmeza los cables de comunicación al panel o al armario.
- Use únicamente un conector Sub-D de 9 pines o cables RJ45 que cuentan con una lengüeta de bloqueo en buenas condiciones.

Si no sigue estas instrucciones, puede provocar daños personales o daños en el equipo.

1. Conexión para la interface serie

La distribución de los pines de cada interface serie se describe en las páginas de referencia.

	COM1	COM2
HMIGTO1300	RS-232C (véase la página 134)	RS-485 (véase la página 136)
HMIGTO1310	RS-232C/RS-485 (véase la página 135)	-
HMIGTO2300	RS-232C (véase la página 134)	RS-485 (véase la página 136)
HMIGTO2310	RS-232C (véase la página 134)	RS-485 (véase la página 136)
HMIGTO2315	RS-232C (véase la página 134)	RS-485 (véase la página 136)
HMIGTO3510	RS-232C (véase la página 134)	RS-485 (véase la página 136)
HMIGTO4310	RS-232C (véase la página 134)	RS-485 (véase la página 136)
HMIGTO5310	RS-232C (véase la página 134)	RS-485 (véase la página 136)
HMIGTO5315	RS-232C (véase la página 134)	RS-485 (véase la página 136)
HMIGTO6310	RS-232C (véase la página 134)	RS-485 (véase la página 136)
HMIGTO6315	RS-232C (véase la página 134)	RS-485 (véase la página 136)

2. RS-232C

Conector Sub-D de 9 pines a través de un cable RS-232C.

N.º del contacto	RS-232C		
	Nombre de la señal	Dirección	Significado
1	CD	Entrada	Detección de la portadora
2	RD(RXD)	Entrada	Recibir datos
3	SD(TXD)	Salida	Enviar datos
4	ER(DTR)	Salida	Terminal de datos preparado
5	SG	–	Toma de tierra de señalización
6	DR(DSR)	Entrada	Conjunto de datos preparado
7	RS(RTS)	Salida	Solicitud de envío
8	CS(CTS)	Entrada	Envío posible
9	CI(RI)/VCC	Entrada/–	Pantalla de estado llamado +5V±5% Salida 0,25A
Cubierta	FG	–	Toma de tierra (común con SG)

Use el software para alternar el contacto #9 entre RI y VCC.

AVISO

DAÑO EN EL EQUIPO

Use únicamente la corriente nominal.

Si no sigue las instrucciones, puede provocar daños en el equipo.

El soporte Interfit es #4-40 (UNC).

3. RS-232C/RS-485

Conector RJ-45 a través de un cable RS-232C o RS-485.

Nota: Cuando establezca la comunicación a través de RS-485, puede que el esquema del cableado de algunos equipos requiera la polarización del terminal. Este terminal no requiere ninguna configuración especial ya que maneja la polarización automáticamente.

N.º del contacto	RS-232C/RS-485		
	Nombre de la señal	Dirección	Significado
1	RD(RXD)	Entrada	Recibir datos (RS-232C)
2	SD(TXD)	Salida	Enviar datos (RS-232C)
3	NC	–	–
4	D1	Entrada/ Salida	Transferir datos (RS-485)
5	D0	Entrada/ Salida	Transferir datos (RS-485)
6	RS(RTS)	Salida	Solicitud de envío
7	NC	–	–
8	SG	–	Toma de tierra de señalización
Cubierta	FG	–	Toma de tierra (común con SG)

4. RS-485

Conector RJ-45 a través de un cable RS-485.

Nota: Cuando establezca la comunicación a través de RS-485, puede que el esquema del cableado de algunos equipos requiera la polarización del terminal. Este terminal no requiere ninguna configuración especial ya que maneja la polarización automáticamente

N.º del contacto	RS-485		
	Nombre de la señal	Dirección	Significado
1	NC	–	–
2	NC	–	–
3	NC	–	–
4	Línea A	Entrada/Salida	Transferir datos (RS-485)
5	Línea B	Entrada/Salida	Transferir datos (RS-485)
6	RS(RTS)	Salida	Solicitud de envío
7	NC	–	no hay conexión
8	SG	–	Toma de tierra de señalización

1. Requisitos de instalación

- Determine el grosor de la carcasa basado en el nivel de resistencia necesario: de 1,6 mm (0,06 in.) a 5 mm (0,2 in.).
- Compruebe que el panel de instalación o la superficie del armario sea liso, que esté en buen estado y que no presente bordes dentados.
- Incluso si el grosor del panel se encuentra dentro del rango recomendado para las "Dimensiones de Corte del Panel", el panel se puede combar en función del material y tamaño del mismo, así como el lugar donde instala el panel de Magelis GTO u otros dispositivos. Para prevenir que el panel se comba, puede que sea necesario reforzar la superficie de la instalación.
- Asegúrese que la temperatura ambiente del aire y la humedad ambiental se encuentren dentro de los niveles especificados.

Temperatura ambiente del aire:

de 0 a 50 °C (32 a 122 °F): HMIGTO1300/1310, HMIGTO2300, HMIGTO3510.

de 0 a 55 °C (32 a 131 °F): HMIGTO2310/2315, HMIGTO4310, HMIGTO5310/5315, HMIGTO6310/6315.

Humedad ambiental: de 10 a 90% de humedad relativa; temperatura húmeda:

máximo de 39 °C (102 °F). Cuando instale la pantalla Magelis GTO en un armario o carcasa, la temperatura ambiente es la temperatura del interior del armario o la carcasa.

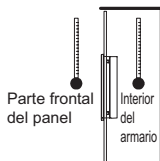

- Asegúrese que el calor despedido por equipos cercanos no provoque que la pantalla Magelis GTO supere su temperatura de funcionamiento estándar.
- Si coloca la pantalla Magelis GTO verticalmente, asegúrese que el costado derecho del panel esté orientado hacia arriba. Es decir, el conector de alimentación para el modelo de CC debe estar situado en la parte superior.

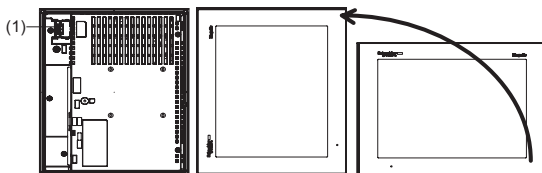

(1) Conector de alimentación

- Cuando instale la pantalla Magelis GTO en posición inclinada, la cara de la pantalla Magelis GTO no debe superar los 30° de inclinación.

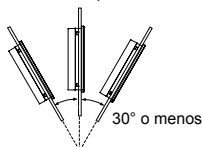

- Si coloca el panel Magelis GTO con una inclinación superior a 30°, la temperatura ambiental no debe superar los 40 °C (104 °F). Puede que sea necesario utilizar un sistema de enfriamiento por aire forzado (ventilador, aire acondicionado) para garantizar que la temperatura ambiente de funcionamiento sea de 40 °C o menos (104 °F o menos).
- Para contar con un funcionamiento y mantenimiento más sencillos, así como con una ventilación mejorada, instale la unidad a una distancia mínima de 100 mm [3,94 in.] de otros equipos y estructuras adyacentes, tal como se muestra en la siguiente ilustración:

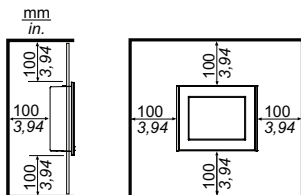

- Los agujeros en la parte trasera del panel Magelis GTO (excepto HMIGTO1300/1310) no corresponden a las normas VESA de 75 mm. No sujete el panel Magelis GTO a un brazo VESA de uso comercial.

2. Procedimiento de instalación (excepto HMIGTO2315/5315/6315)

AVISO

PANEL INESTABLE CUANDO NO ESTÁ SUJETO

Asegúrese que el equipo Magelis GTO se mantenga estabilizado en el corte del panel cuando instale o remueva los elementos de fijación.

Si no sigue las instrucciones, puede provocar daños en el equipo.

Paso	Acción
1	Coloque la Magelis GTO en una superficie limpia y plana con la pantalla orientada hacia abajo.
2	<p>Compruebe que la junta de la pantalla Magelis GTO esté colocada firmemente en la ranura de la junta, la cual recorre el perímetro del marco del panel.</p> <p>Nota: Se recomienda que use la junta de instalación, ya que absorbe las vibraciones y repela el agua.</p> <p>Consulte el "Manual del usuario de Magelis GTO" para ver el procedimiento para reemplazar la junta de instalación.</p>

- 3 Haga un corte en el panel e introduzca la pantalla Magelis GTO en parte frontal del panel.

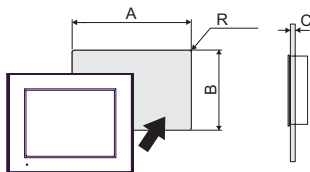

HMIGTO1300/1310

A	B	C	R
118,5 ⁺¹ ₋₀ mm (4,67 ^{+0.04} ₋₀ in.)	92,5 ⁺¹ ₋₀ mm (3,64 ^{+0.04} ₋₀ in.)	1,6...5 mm (0,06...0,2 in)	3 mm (0,12 in.) máximo

HMIGTO2300/2310

A	B	C	R
156 ⁺¹ ₋₀ mm (6,14 ^{+0.04} ₋₀ in.)	123,5 ⁺¹ ₋₀ mm (4,86 ^{+0.04} ₋₀ in.)	1,6...5 mm (0,06...0,2 in)	3 mm (0,12 in.) máximo

HMIGTO3510/HMIGTO4310

A	B	C	R
204,5 ⁺¹ ₋₀ mm (8,05 ^{+0.04} ₋₀ in.)	159,5 ⁺¹ ₋₀ mm (6,28 ^{+0.04} ₋₀ in.)	1,6...5 mm (0,06...0,2 in)	3 mm (0,12 in.) máximo

HMIGTO5310

A	B	C	R
259 ⁺¹ ₋₀ mm (10,2 ^{+0.04} ₋₀ in.)	201 ⁺¹ ₋₀ mm (7,91 ^{+0.04} ₋₀ in.)	1,6...5 mm (0,06...0,2 in)	3 mm (0,12 in.) máximo

HMIGTO6310

A	B	C	R
301,5 ⁺¹ ₋₀ mm (11,87 ^{+0.04} ₋₀ in.)	227,5 ⁺¹ ₋₀ mm (8,96 ^{+0.04} ₋₀ in.)	1,6...5 mm (0,06...0,2 in)	3 mm (0,12 in.) máximo

<p>4</p>	<p>Inserte las fijaciones de montaje en las ranuras de inserción de Magelis GTO en las partes superior e inferior (costados izquierdo y derecho para HMIGTO1300/1310.) Si las fijaciones no se sujetan correctamente, la pantalla Magelis GTO puede moverse o caerse del panel.</p> <p>Panel de instalación</p> <p>Gancho</p> <p>Logements (HMIGTO1310)</p> <p>Ranuras (HMIGTO2310)</p>
<p>5</p>	<p>Deslice las fijaciones hacia atrás.</p>
<p>6</p>	<p>Utilice un destornillador para apretar cada uno de los tornillos y sujetar la pantalla Magelis GTO. El par de apriete necesario es de 0,5 Nm (4,4 lbs-in.):</p>

Español

AVISO

CARCASA DAÑADA

- No aplique más de 0,5 Nm (4,4 in-lb) de par de apriete a los tornillos de fijación.
- Usar en una superficie plana de una carcasa de Tipo 1, Tipo 4X (sólo para uso en interiores) o Tipo 13

Si no sigue las instrucciones, puede provocar daños en el equipo.

3. Procedimiento de remoción (excepto HMIGTO2315/5315/6315)

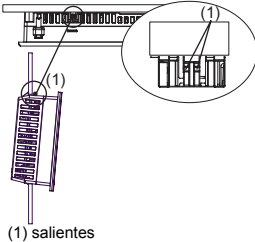
Paso	Acción
1	Afloje las fijaciones de montaje (4) de la pantalla Magelis GTO.
2	<p>Remueva la pantalla Magelis GTO del panel cuidadosamente mientras presiona los salientes en la parte superior de la pantalla Magelis GTO.</p>  <p>(1) salientes</p> <p>Nota:</p> <ul style="list-style-type: none"> • Puede dañar la pantalla Magelis GTO si intenta removerla sin presionar los salientes. • Tenga cuidado de no lastimarse cuando presione los salientes.

▲ PRECAUCIÓN

RIESGO DE DAÑOS PERSONALES

No deje que la pantalla Magelis GTO se caiga cuando la remueva del panel.

- Sujétela después de quitar las fijaciones.
- Use las dos manos.

Si no sigue las instrucciones, puede provocar daños personales o daños en el equipo.

4. Procedimiento de instalación (HMIGTO2315/5315/6315)

PRECAUCIÓN

RIESGO DE DAÑOS PERSONALES

No deje que la pantalla Magelis GTO se caiga cuando la instale o la remueva del panel.

- Sujétela después de quitar las tuercas hexagonales M4 y los soportes.
- Use las dos manos.

Si no sigue las instrucciones, puede provocar daños personales o daños en el equipo.

AVISO

PANEL INESTABLE CUANDO NO ESTÁ SUJETO

Mantenga el panel Magelis GTO estable en el corte del panel cuando instale o quite las tuercas hexagonales M4 y los soportes.

Si no sigue las instrucciones, puede provocar daños en el equipo.

Paso	Acción
1	Coloque la Magelis GTO en una superficie limpia y plana con la pantalla orientada hacia abajo.
2	Confirme que la junta de la pantalla Magelis GTO esté colocada correctamente en la parte trasera de la pantalla.

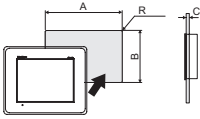
Paso	Acción																								
3	<p>Haga un corte en el panel e introduzca la pantalla Magelis GTO en el mismo desde la parte frontal.</p>  <p>HMIGTO2315</p> <table border="1" data-bbox="217 414 875 546"> <thead> <tr> <th>A</th> <th>B</th> <th>C</th> <th>R</th> </tr> </thead> <tbody> <tr> <td>195⁺¹₋₀ mm (7,68^{+0.04}₋₀ in.)</td> <td>162,5⁺¹₋₀ mm (6,40^{+0.04}₋₀ in.)</td> <td>1,6...5 mm (0,06...0,2 in)</td> <td>3 mm (0,12 in.) máximo</td> </tr> </tbody> </table> <p>HMIGTO5315</p> <table border="1" data-bbox="217 618 875 749"> <thead> <tr> <th>A</th> <th>B</th> <th>C</th> <th>R</th> </tr> </thead> <tbody> <tr> <td>298⁺¹₋₀ mm (11,73^{+0.04}₋₀ in.)</td> <td>240⁺¹₋₀ mm (9,45^{+0.04}₋₀ in.)</td> <td>1,6...5 mm (0,06...0,2 in)</td> <td>3 mm (0,12 in.) máximo</td> </tr> </tbody> </table> <p>HMIGTO6315</p> <table border="1" data-bbox="217 800 875 931"> <thead> <tr> <th>A</th> <th>B</th> <th>C</th> <th>R</th> </tr> </thead> <tbody> <tr> <td>340,5⁺¹₋₀ mm (13,41^{+0.04}₋₀ in.)</td> <td>266,5⁺¹₋₀ mm (10,49^{+0.04}₋₀ in.)</td> <td>1,6...5 mm (0,06...0,2 in)</td> <td>3 mm (0,12 in.) máximo</td> </tr> </tbody> </table>	A	B	C	R	195 ⁺¹ ₋₀ mm (7,68 ^{+0.04} ₋₀ in.)	162,5 ⁺¹ ₋₀ mm (6,40 ^{+0.04} ₋₀ in.)	1,6...5 mm (0,06...0,2 in)	3 mm (0,12 in.) máximo	A	B	C	R	298 ⁺¹ ₋₀ mm (11,73 ^{+0.04} ₋₀ in.)	240 ⁺¹ ₋₀ mm (9,45 ^{+0.04} ₋₀ in.)	1,6...5 mm (0,06...0,2 in)	3 mm (0,12 in.) máximo	A	B	C	R	340,5 ⁺¹ ₋₀ mm (13,41 ^{+0.04} ₋₀ in.)	266,5 ⁺¹ ₋₀ mm (10,49 ^{+0.04} ₋₀ in.)	1,6...5 mm (0,06...0,2 in)	3 mm (0,12 in.) máximo
A	B	C	R																						
195 ⁺¹ ₋₀ mm (7,68 ^{+0.04} ₋₀ in.)	162,5 ⁺¹ ₋₀ mm (6,40 ^{+0.04} ₋₀ in.)	1,6...5 mm (0,06...0,2 in)	3 mm (0,12 in.) máximo																						
A	B	C	R																						
298 ⁺¹ ₋₀ mm (11,73 ^{+0.04} ₋₀ in.)	240 ⁺¹ ₋₀ mm (9,45 ^{+0.04} ₋₀ in.)	1,6...5 mm (0,06...0,2 in)	3 mm (0,12 in.) máximo																						
A	B	C	R																						
340,5 ⁺¹ ₋₀ mm (13,41 ^{+0.04} ₋₀ in.)	266,5 ⁺¹ ₋₀ mm (10,49 ^{+0.04} ₋₀ in.)	1,6...5 mm (0,06...0,2 in)	3 mm (0,12 in.) máximo																						

Español

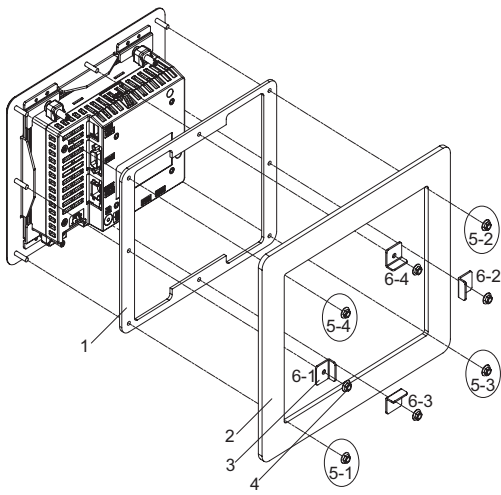
Paso	Acción
<p>4</p>	<p>Inserte la pantalla Magelis GTO en el corte del panel.</p>  <p>1 Junta 2 Panel 3 Soportes 4 Tuercas hexagonales M4 5 Lea el paso 5. 6 Lea el paso 6.</p>
<p>5</p>	<p>Apriete las cuatro esquinas en la parte trasera de la pantalla Magelis GTO usando tuercas hexagonales M4 en el orden que se muestra en el ejemplo en el paso 4. Utilice un destornillador de cabeza cuadrada M4 para apretar cada una de las tuercas hexagonales M4 y sujetar la pantalla Magelis GTO. El par de apriete necesario es de 0,5 Nm (4,4 lbs-in.). Si las tuercas hexagonales M4 no se fijan correctamente, la pantalla Magelis GTO puede moverse o caerse del panel.</p>

Paso	Acción
6	<p>Coloque el soporte en los tornillos en el punto medio entre las tuercas hexagonales M4 en el orden que se muestra en el ejemplo en el paso 4.</p> <p>Utilice un destornillador de cabeza cuadrada M4 para apretar cada una de las tuercas hexagonales M4 y sujetar la pantalla Magelis GTO. El par de apriete necesario es de 0,5 Nm (4,4 lbs-in.). Si las tuercas hexagonales M4 no se fijan correctamente, la pantalla Magelis GTO puede moverse o caerse del panel.</p>
7	<p>Apriete todas las tuercas hexagonales M4 de nuevo. El par de apriete necesario es de 0,5 Nm (4,4 lbs-in.).</p> <p>Nota: No afloje las fijaciones de instalación marcadas con cuadrados rojos a continuación.</p> <div data-bbox="238 546 564 829" style="text-align: center;"> <p>(1)</p> </div> <p>1 Panel</p>

AVISO

CARCASA DAÑADA

- No aplique más de 0,5 Nm (4.4 in-lb) de par de apriete a las tuercas hexagonales M4.
- Usar en una superficie plana de una carcasa de Tipo 1, Tipo 4X (sólo para uso en interiores) o Tipo 13

Si no sigue las instrucciones, puede provocar daños en el equipo.

⚠ ADVERTENCIA

EXCESO DE INTERFERENCIA ELECTROMAGNÉTICA

- Cuando conecte el terminal de toma de tierra (FG), asegúrese que el cable esté conectado a tierra. Si no conecta la pantalla Magelis GTO a tierra, puede provocar un exceso de interferencia electromagnética (EMI por su sigla en inglés). La conexión a tierra es necesaria para cumplir con la protección de nivel de compatibilidad electromagnética.
- Desconecte todas las fuentes de alimentación del dispositivo antes de remover cualquier elemento del sistema y antes de instalar o desconectar cualquier accesorio, hardware o cable.
- Desconecte la alimentación antes de cablear los terminales de alimentación de la pantalla Magelis GTO.
- El modelo de CC sólo usa energía de 24 Vcc. Si usa cualquier otro nivel de alimentación, puede dañar la fuente de alimentación y la pantalla Magelis GTO.
- Puesto que la pantalla Magelis GTO no está equipada con un interruptor de alimentación, asegúrese de conectar uno a la fuente de alimentación.
- Asegúrese de conectar a tierra el terminal FG de Magelis GTO.
- Reemplace y sujete todos los elementos del sistema antes de suministrar la alimentación a la pantalla Magelis GTO.

Si no sigue estas instrucciones, puede provocar la muerte, serios daños personales o daños en el equipo.

Nota: Los terminales SG y FG se conectan en el interior de la pantalla Magelis GTO.

Conexión del cable de alimentación CC

Utilice sólo conductores de cobre.

Temperatura nominal de los conductores instalados en campo: sólo 75°C (167 °F).

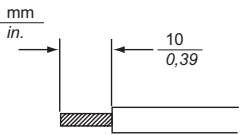
Diámetro del cable de alimentación	De 0,75 a 2,5 mm ² (18-13 AWG)
Tipo de conductor	Cable simple o trenzado*1
Longitud del conductor	

*1 Si los extremos de los cables (individuales) del conductor no se trenzan correctamente, se puede producir un bucle de cortocircuito entre los extremos de cable o entre los extremos y un electrodo.

Especificaciones del conector de alimentación

HMIGTO1300/1310 /
HMIGTO2300/2310/2315 /
HMIGTO3510/4310

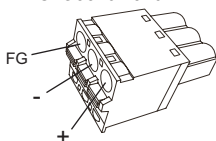

HMIGTO5310/5315 /
HMIGTO6310/6315

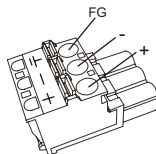

Conexión	Cable
+	24 Vcc
-	0 Vcc
FG	Terminal con toma de tierra conectado al chasis del panel.

Conexión del cable de alimentación CC

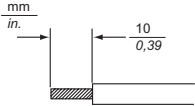
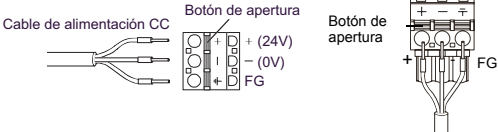
Paso	Acción
1	Confirme que el cable de alimentación no esté conectado a la fuente de alimentación.
2	Compruebe la tensión nominal y retire la pegatina "DC24V" en el conector de la fuente de alimentación CC.
3	Quite 10 mm (0,39 in.) de la membrana de vinilo de los extremos de los cables del cordón de alimentación.
	
4	Si está utilizando cable trenzado, trence los extremos. Estañar los extremos reduce el riesgo de que se deshilachen y asegura una buena transferencia eléctrica.
5	Presione el botón de apertura usando un pequeño destornillador plano para abrir el agujero deseado.
6	<p>Introduzca cada terminal del pin en el orificio correspondiente. Libere el botón de apertura para sujetar el pin.</p> <p>HMIGTO1300/1310 / HMIGTO2300/2310/2315 / HMIGTO3510 / HMIGTO4310</p> <p>HMIGTO5310/5315 / HMIGTO6310/6315</p> 
7	Después de introducir los tres pines, introduzca el conector de la fuente de alimentación CC en el conector de alimentación en la pantalla Magelis GTO.

Nota:

- No suelde el cable directamente al pin del receptáculo de alimentación.
- Para prevenir la posibilidad de un cortocircuito en el terminal, use un bornero con una manga aislante.

- Puede conectar la toma de la fuente de alimentación CC de HMIGTO1300/1310, HMIGTO2300/2310/2315, HMIGTO3510 o HMIGTO4310 a HMIGTO5310/5315 o HMIGTO6310/6315I sin embargo, no se puede realizar la conexión opuesta. No puede conectar la toma de la fuente de alimentación CC de HMIGTO5310/5315 o HMIGTO6310/6315 a HMIGTO1300/1310, HMIGTO2300/2310/2315, HMIGTO3510 o HMIGTO4310.

Precauciones al realizar el cableado

Mejora de la resistencia al ruido/sobretensiones

- El cordón de la fuente de alimentación de la pantalla Magelis GTO no se debe agrupar con líneas de circuitos principales (alta tensión, alta corriente) ni con líneas de señales de entrada/salida, ni colocarse cerca de las mismas, y todos los sistemas se deben mantener separados. Si las líneas eléctricas no se pueden cablear a través de un sistema separado, use cables blindados para las líneas de entrada/salida.
- Asegúrese que el cordón de alimentación sea lo más corto posible y trence los extremos de los cables (por ejemplo, cableado trenzado) cerca de fuente de alimentación.
- Si se produce un exceso de ruido en la línea de alimentación, conecte un transistor para reducir los ruidos antes de encender el equipo.
- Conecte un supresor de sobretensiones para controlar las subidas de tensión. Asegúrese de conectar el supresor de sobretensiones (E1) a tierra separado de la pantalla Magelis GTO (E2).

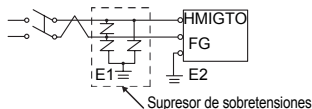

Prevención de cortocircuitos

- Los terminales de SG (toma de tierra de señalización) y FG (toma de tierra) se conectan en el interior de la pantalla Magelis GTO. Cuando conecte la línea de SG a otro dispositivo, asegúrese que no se forme un bucle de cortocircuito.

Conexión a tierra

- Use un cable de puesta a tierra exclusivo con una resistencia de 100Ω o menos y un cable con un grosor de 2 mm^2 (AWG 14) o más, o la normativa aplicable de su país.

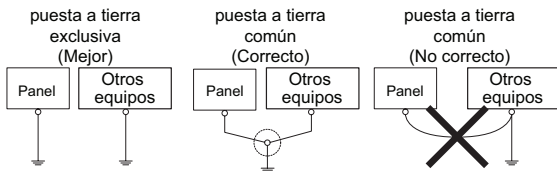

Abrazadera del cable USB

Cuando use un dispositivo USB, coloque una abrazadera del cable USB al interface USB para evitar que se desconecte el cable USB.

⚠ ADVERTENCIA

RIESGO DE EXPLOSIÓN EN LUGARES PELIGROSOS

- Verifique que el cableado de la alimentación, entrada y salida (E/S) cumple los métodos de cableado de Clase I, División 2.
- No sustituya ningún componente que pueda anular la conformidad con la Clase I, División 2.
- Confirme que el cable USB ha sido sujetado con la abrazadera del cable USB antes de usar el interface USB.
- Apague la alimentación antes de conectar o desconectar un conector del panel.

Si no sigue estas instrucciones, puede provocar la muerte, serios daños personales o daños en el equipo.

1. Sujeción de la abrazadera de cable USB Tipo A:

Nota: Tenga cuidado cuando coloque la abrazadera. El clip tiene un borde afilado.

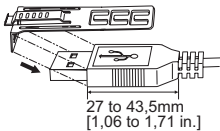
Paso	Acción
1	<p>Coloque el clip en la cubierta del conector del símbolo  de USB de modo que se superponga. El clip coincide con la longitud de 27 a 43,5 mm (1,06 a 1,71 in.) del conector USB.</p> 

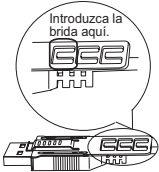
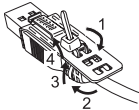
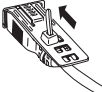
2	<p>Alinee el clip y la cubierta del conector del cable USB. Ajuste la posición de los orificios donde ha colocado la clip. Para asegurar su estabilidad, seleccione la posición del orificio del clip más cercana a la base de la cubierta del conector.</p> 
3	<p>Tal como se muestra en el dibujo, pase la brida de cable por el orificio del clip. Luego gire la brida y pásela por la cabeza de modo que el cable USB pueda pasar por el centro del lazo de la brida. Ahora el clip está colocado al cable USB.</p>  <p>Nota:</p> <ul style="list-style-type: none">• Compruebe la orientación de la cabeza de antemano. Asegúrese que el cable USB haya pasado por el centro del lazo de la brida y que ésta puede pasar por la cabeza.• Puede sustituir la brida de cables en el paquete con otras disponibles comercialmente con un ancho de 4,8 mm [0,19 in] y un grosor de 1,3 mm [0,05 in].
4	<p>Mientras presiona el área de agarre del clip clip, introduzca el cable del paso 3 completamente dentro de la interface del USB principal. Asegúrese que la lengüeta del clip esté firmemente sujeta al cable USB conectado a la pantalla Magelis GTO.</p> 

2. Remoción del cable USB Tipo A

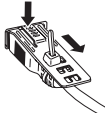
Paso	Acción
1	<p>Extraiga el cable USB mientras presiona el área de agarre del clip.</p> 

3. Sujeción de la abrazadera del cable USB mini B:

Nota: Tenga cuidado cuando coloque la abrazadera. El clip tiene un borde afilado.

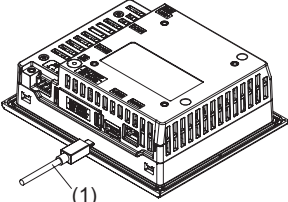
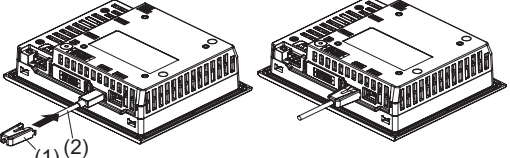
Paso	Acción
1	<p>Inserte el cable USB en la interface del USB (mini B).</p>  <p>Un cable USB</p>
2	<p>Coloque el soporte del USB para sujetar el cable USB. Inserte el soporte del USB en la interface del USB (mini B).</p>  <p>1 Soporte de USB 2 Cable USB</p>

4. Remoción del soporte del USB

Paso	Acción
1	Presione las lengüetas de los costados y remueva el soporte del USB.

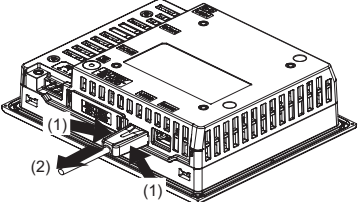

1 Soporte de USB
2 Cable USB

Normas pertinentes

El N.º del Modelo de Registro se muestra a continuación:

- HMIGTO1300
- HMIGTO1310
- HMIGTO2300
- HMIGTO2310
- HMIGTO2315
- HMIGTO3510
- HMIGTO4310
- HMIGTO5310
- HMIGTO5315
- HMIGTO6310
- HMIGTO6315

La pantalla Magelis GTO se fabrica de acuerdo con:

- Norma UL 508 y CSA C22.2 n°142 para Equipos de Control Industrial

Nota:

- Destinada a un uso en un entorno que presente un nivel de contaminación 2.
- Destinada para uso en una superficie plana de una carcasa Tipo 1, Tipo 4X (sólo usar en interiores) o Tipo 13.
- Un panel de entrada de 24 Vcc debe utilizarse con una fuente de alimentación de Clase 2.
- Sólo para uso en Emplazamientos Peligrosos de Clase 1, División 2.
- Norma ANSI/ISA - 12.12.01 y CSA C22.2 n°213 para Equipos Eléctricos destinados para uso en Emplazamientos Peligrosos de Clase 1, División 2
- Certificación GOST.
Consulte el marcado del producto.
- Certificación ATEX otorgada por Technical Inspection Association.
Consulte la etiqueta del producto.
- Reglamentos de la Marina Mercante (Excepto Magelis GTOxxx5).
Los productos han sido diseñados en cumplimiento con los reglamentos de la Marina Mercante.
Consulte el portal de Schneider Electric para ver las directrices de instalación de los reglamentos de la Marina Mercante.
- Norma EN1672-2 (Magelis GTOxxx5).
- Reglamento de la FDA 21 CFR 177 (Magelis GTOxxx5).

ADVERTENCIA

RIESGO DE EXPLOSIÓN EN LUGARES PELIGROSOS

- Verifique que el cableado de la alimentación, entrada y salida (E/S) cumpla los métodos de cableado de Clase 1, División 2.
- No sustituya ningún componente que pueda anular la conformidad con la Clase 1, División 2.
- No conecte ni desconecte el equipo a menos que se haya apagado la alimentación o que el emplazamiento no sea peligroso.
- No lo desconecte cuando el circuito está bajo tensión.
- Bloquee las unidades externas conectadas y cada interface firmemente antes de encender la fuente de alimentación.
- No utilice ni conecte ni desconecte el cable USB a menos que esté seguro que el área no sea peligroso.
- Posible peligro de descargas electrostáticas: limpie el panel frontal del terminal con un paño húmedo antes de encenderlo.

Si no sigue estas instrucciones, puede provocar la muerte, serios daños personales o daños en el equipo.

▲ PRECAUCIÓN

PELIGROS AMBIENTALES QUE AFECTAN AL EQUIPO

- Deje que el dispositivo alcance la temperatura ambiente del aire, sin exceder los siguientes valores, antes de encender el dispositivo:
50°C (122°F): HMIGTO1300/1310, HMIGTO2300, HMIGTO3510.
55°C (131°F): HMIGTO2310/2315, HMIGTO4310, HMIGTO5310/5315 y HMIGTO6310/HMIGTO6315.
- No apague el dispositivo si se produce condensación dentro del mismo. Una vez que el dispositivo esté completamente seco, lo puede encender.
- No exponga el dispositivo a la luz directa del sol.
- No obstruya la ventilación en la carcasa del dispositivo..
- Limpie el polvo del dispositivo antes de encenderlo.
- Asegúrese que las fijaciones del cable no estén dañadas. Reemplácelas si fuese necesario.
- Sólo el personal cualificado está autorizado para cambiar la batería principal.
- Coloque el dispositivo en una carcasa que cumpla con el nivel de protección IP54 para la categoría 3G, IP6x para la categoría 3D, y los requisitos relacionados a las categorías 3G o 3D en las Zonas 2/22 (Categoría 3: nivel de protección normal - G: Gas - P: Polvo).

Si no sigue estas instrucciones, puede provocar daños personales o daños en el equipo.

La pantalla Magelis GTO se debe instalar, utilizar y mantener de acuerdo con las siguientes normas:

- Normas WEEE, Directiva 2002/96/EC
- Normas RoHS, Directiva 2002/95/EC
- Normas RoHS China, Normas SJ/T 11363-2006

Indice

Descrizione generale

Contenuto della confezione	162
----------------------------------	-----

Specifiche elettriche

1. HMIGTO1300/1310/2300/2310/2315/3510/4310	163
2. HMIGTO5310/5315/6310/6315	164

Numeri parti e funzioni

1. HMIGTO1300/1310	165
2. HMIGTO2300/2310/2315	166
3. HMIGTO3510/4310	168
4. HMIGTO5310/5315	169
5. HMIGTO6310/6315	170
6. Indicazioni spie	171

Interfaccia

1. Connessione interfaccia seriale.....	173
2. RS-232C.....	174
3. RS-232C/RS-485.....	175
4. RS-485	176

Installazione

1. Requisiti per l'installazione	177
2. Procedura di installazione(eccetto HMIGTO2315/5315/6315).....	179
3. Procedura di rimozione (eccetto HMIGTO2315/5315/6315)	183
4. Procedura di installazione (HMIGTO2315/5315/6315).....	184

Cablaggio

Cablaggio	188
-----------------	-----

Morsetto serracavo USB

1. Attaccare il morsetto serracavo USB Tipo A	192
2. Rimuovere il cavo USB Tipo A	194
3. Attaccare il morsetto serracavo USB mini-B	194
4. Rimuovere il sostegno USB.....	195

Standard

Standard applicabili	196
----------------------------	-----

Contenuto della confezione

Nella confezione sono contenuti i seguenti componenti. Prima di utilizzare il Magelis GTO, verificare la presenza di tutti i componenti elencati:

- 1 Magelis GTO: 1
- 2 Guarnizione d'installazione 1 (accluso al Magelis GTO)
- 3 Elementi di fissaggio per l'installazione 4 per set
- 4 Staffe: 4
- 5 Dadi esagonali M4: 8
- 6 Connettore alimentazione CC: 1
- 7 Morsetto cavo USB tipo A: 1 set (1 molletta e 1 laccio)
- 8 Morsetto cavo USB mini-B: 1 (1 sostegno USB)
- 9 Guida rapida Magelis GTO (questa guida): 1

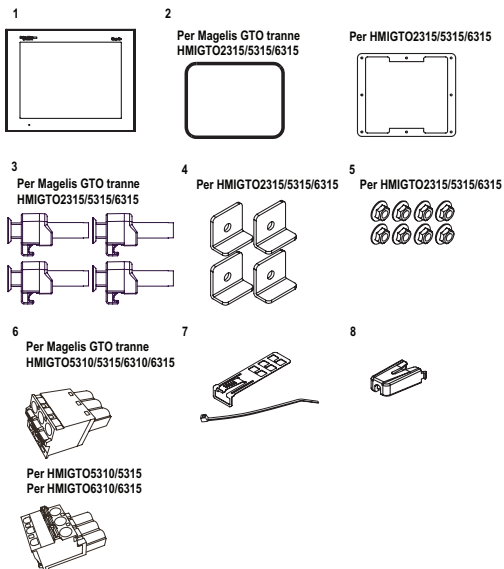

Il pannello è stato imballato con cura, facendo particolare attenzione alla qualità. Nel caso qualcosa sia danneggiata o mancante, rivolgersi immediatamente al proprio distributore di zona.

1. HMIGTO1300/1310/2300/2310/2315/3510/4310

Specifiche		HMIGTO1300 HMIGTO1310	HMIGTO2300 HMIGTO2310 HMIGTO2315	HMIGTO3510 HMIGTO4310	
Alimentazione	Tensione d'ingresso nominale	24 VCC			
	Limiti della tensione di ingresso	19,2...28,8 VCC			
	Caduta di tensione	2 ms o minore	5 ms o minore		
	Assorbimento		9,6W o minore	10,5W o minore	12W o minore
		In assenza di alimentazione a dispositivi esterni	5,2W o minore	6,5W o minore	8W o minore
		Retroilluminazione spenta (Modalità standby)	4,2W o minore	4,5W o minore	5W o minore
		Retroilluminazione attenuata (Luminosità: 20%)	4,3W o minore	5W o minore	5,5W o minore
	Corrente di spunto	30 A o minore			
Durata della tensione	1.000 VCA, 20 mA per 1 minuto (tra carica e terminali FG)				
Resistenza di isolamento	500 VCC, 10 MΩ o maggiore (tra carica e terminali FG)				

2. HMIGTO5310/5315/6310/6315

Specifiche		HMIGTO5310/HMIGTO5315/ HMIGTO6310/HMIGTO6315
Alimentazione	Tensione d'ingresso nominale	24 VCC
	Limiti della tensione di ingresso	19,2...28,8 VCC
	Caduta di tensione	10 ms o minore
	Assorbimento	17W o minore
	In assenza di alimentazione a dispositivi esterni	12W o minore
	Retroilluminazione spenta (Modalità standby)	7W o minore
	Retroilluminazione attenuata (Luminosità: 20%)	8W o minore
Corrente di spunto	30 A o minore	
Durata della tensione	1.000 VCA, 20 mA per 1 minuto (tra carica e terminali FG)	
Resistenza di isolamento	500 VCC, 10 M Ω o maggiore (tra carica e terminali FG)	

1. HMIGTO1300/1310

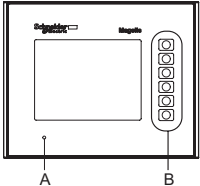
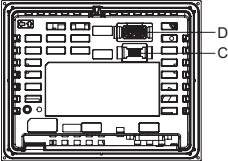
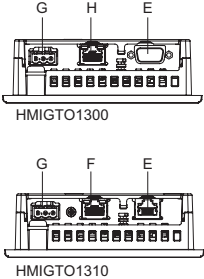
Fronte	
Retro	
Fondo	

- A: LED di stato (vedere pagina 171)
- B: Interruttori funzione
- C: Interfaccia USB (mini-B)
- D: Interfaccia USB (Tipo A)
- E: Interfaccia seriale (COM1)
- F: Interfaccia Ethernet (vedere pagina 171)
- G: Connettore di alimentazione
- H: Interfaccia seriale (COM2)

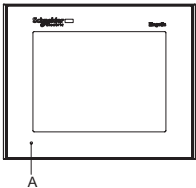
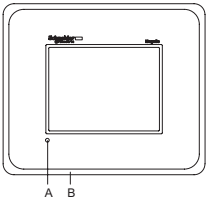
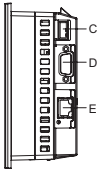
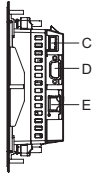
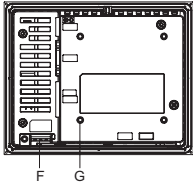
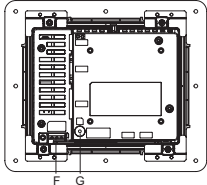
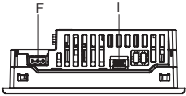
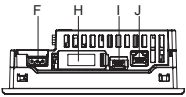
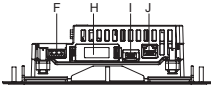

2. HMIGTO2300/2310/2315

	HMIGTO2300/2310	HMIGTO2315
Fronte		
Destra		
Retro		
Fondo	 HMIGTO2300  HMIGTO2310	

- A: LED di stato (vedere pagina 171)
- B: Cornice in acciaio inossidabile
- C: Interfaccia USB (Tipo A)
- D: Interfaccia seriale (COM1)
- E: Interfaccia seriale (COM2) (vedere pagina 171)
- F: Connettore di alimentazione
- G: Spia di accesso SD Card (vedere pagina 171)*¹
- H: Sportellino interfaccia SD Card/Sportellino inserimento batteria di ricambio*¹
- I: Interfaccia USB (mini-B)
- J: Interfaccia Ethernet (vedere pagina 171)

*1 Solo per HMIGTO2310 e HMIGTO2315.

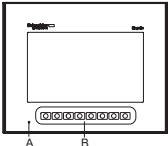
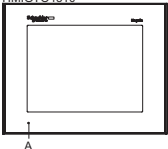
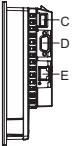
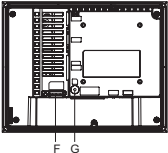
3. HMIGTO3510/4310

<p>Fronte</p>	<p>HMIGTO3510</p>  <p>HMIGTO4310</p> 
<p>Destra</p>	
<p>Retro</p>	
<p>Fondo</p>	



A: LED di stato (vedere pagina 171)

B: Interruttori funzione

C: Interfaccia USB (Tipo A)

- D: Interfaccia seriale (COM1)
 E: Interfaccia seriale (COM2) (vedere pagina 171)
 F: Connettore di alimentazione
 G: Spia di accesso SD Card (vedere pagina 171)
 H: Sportellino interfaccia SD Card/Sportellino inserimento batteria di ricambio
 I: Interfaccia USB (mini-B)
 J: Interfaccia Ethernet (vedere pagina 171)

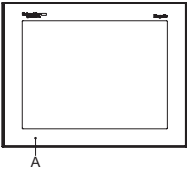
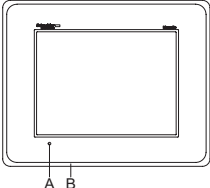
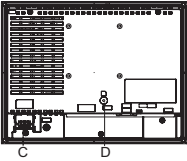
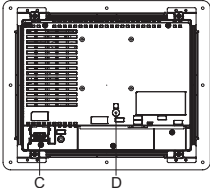

4. HMIGTO5310/5315

	HMIGTO5310	HMIGTO5315
Fronte		
Retro		
Fondo		

- A: LED di stato (vedere pagina 171)
 B: Cornice in acciaio inossidabile
 C: Connettore di alimentazione
 D: Spia di accesso SD Card (vedere pagina 171)
 E: Interfaccia Ethernet (vedere pagina 171)
 F: Interfaccia USB (mini-B)

- G: Sportellino interfaccia SD Card/Sportellino inserimento batteria di ricambio
 H: Interfaccia seriale (COM2) (vedere pagina 171)
 I: Interfaccia seriale (COM1)
 J: Interfaccia USB (Tipo A)

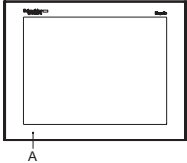
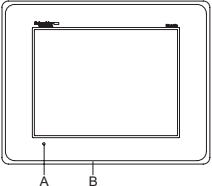
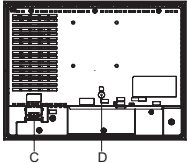
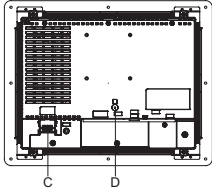
5. HMIGTO6310/6315

	HMIGTO6310	HMIGTO6315
Fronte		
Retro		
Fondo		

- A: LED di stato (vedere pagina 171)
 B: Cornice in acciaio inossidabile
 C: Connettore di alimentazione
 D: Spia di accesso SD Card (vedere pagina 171)
 E: Interfaccia Ethernet (vedere pagina 171)
 F: Interfaccia USB (mini-B)
 G: Sportellino interfaccia SD Card/Sportellino inserimento batteria di ricambio
 H: Interfaccia seriale (COM2) (vedere pagina 171)
 I: Interfaccia seriale (COM1)
 J: Interfaccia USB (Tipo A)

6. Indicazioni spie

(1) LED di stato

Colore	Indicatore	Descrizione
Verde	ON	Non in linea.
		In funzione.
Arancione	Lampeggiante	Software in avviamento.
Rosso	ON	Alimentazione accesa.
–	OFF	Alimentazione spenta.

(2) Spia di accesso SD Card

Colore	Indicatore	Descrizione
Verde (Attivo)	ON	La SD Card è inserita.
	OFF	La SD Card non è inserita o il sistema non sta accedendo alla SD Card.

(3) Spia Ethernet

	Colore	Indicatore	Descrizione
 Link Attivo	Verde (Attivo)	Lampeggiante	Trasmissione dati in corso.
		OFF	Trasmissione dati assente
	Verde (Collegamento)	ON	Trasmissione dati disponibile in 10BASE-T/100BASE-TX.
		OFF	Connessione assente o trasmissione successiva NON disponibile.

(4) Spia COM2

Colore	Indicatore	Descrizione
Giallo	ON	Comunicazione (invio o ricezione dati) in corso.
	OFF	Comunicazione assente.

Interfaccia seriale

La porta seriale non è isolata. I terminali SG (massa segnale) e FG (massa telaio) sono collegati internamente al pannello.



PERICOLO

SHOCK ELETTRICO

Nel caso si utilizzi il terminale SG per collegare un dispositivo esterno al pannello:

- Verificare che non si venga a creare un anello di corto circuito quando si installa il sistema.
- Quando si utilizza il connettore D-Sub 9 pin, collegare il terminale SG #5 all'apparato remoto se l'unità host (PLC) non è isolata. Collegare il terminale SG #5 ad una connessione sicura di massa, per ridurre il rischio di danneggiare il circuito.
- Quando si utilizza il connettore RJ-45, collegare il terminale SG #8 all'apparato remoto se l'unità host (PLC) non è isolata. Collegare il terminale SG #8 ad una connessione sicura di massa, per ridurre il rischio di danneggiare il circuito.

Il mancato rispetto delle istruzioni provoca lesioni gravi o morte.

⚠ ATTENZIONE

PERDITA DI COMUNICAZIONE

- Non sollecitare eccessivamente le porte di comunicazione.
- Fissare saldamente i cavi di comunicazione sulla parete del pannello o del cabinet.
- Utilizzare soltanto cavi SUB-D a 9 pin o RJ45 con sistema di bloccaggio in buone condizioni.

Il mancato rispetto delle istruzioni potrebbe provocare lesioni minori o danni materiali.

1. Connessione interfaccia seriale

L'assegnazione dei pin ad ogni interfaccia seriale è descritta nelle pagine di riferimento.

	COM1	COM2
HMIGTO1300	RS-232C (vedere pagina 174)	RS-485 (vedere pagina 176)
HMIGTO1310	RS-232C/RS-485 (vedere pagina 175)	-
HMIGTO2300	RS-232C (vedere pagina 174)	RS-485 (vedere pagina 176)
HMIGTO2310	RS-232C (vedere pagina 174)	RS-485 (vedere pagina 176)
HMIGTO2315	RS-232C (vedere pagina 174)	RS-485 (vedere pagina 176)
HMIGTO3510	RS-232C (vedere pagina 174)	RS-485 (vedere pagina 176)
HMIGTO4310	RS-232C (vedere pagina 174)	RS-485 (vedere pagina 176)
HMIGTO5310	RS-232C (vedere pagina 174)	RS-485 (vedere pagina 176)
HMIGTO5315	RS-232C (vedere pagina 174)	RS-485 (vedere pagina 176)
HMIGTO6310	RS-232C (vedere pagina 174)	RS-485 (vedere pagina 176)
HMIGTO6315	RS-232C (vedere pagina 174)	RS-485 (vedere pagina 176)

2. RS-232C

Connettore della presa D-Sub a 9 pin mediante cavo RS-232C

Numero pin	RS-232C		
	Nome segnale	Direzione	Significato
1	CD	Ingresso	Rilevamento portante
2	RD(RXD)	Ingresso	Ricezione dati
3	SD(TXD)	Uscita	Invio dati
4	ER(DTR)	Uscita	Terminale dati pronto
5	SG	–	Massa del segnale
6	DR(DSR)	Ingresso	Set dati pronto
7	RS(RTS)	Uscita	Richiesta di invio
8	CS(CTS)	Ingresso	Invio possibile
9	CI(RI)/VCC	Ingresso/-	Chiamata visualizzazione di stato +5V±5% Uscita 0,25A
Involucro	FG	–	Massa del telaio (Comune con SG)

È possibile passare il pin #9 tra RI e VCC via software.

AVVISO

DANNI ALLE APPARECCHIATURE

Usare solo la corrente nominale.

Il mancato rispetto delle istruzioni potrebbe provocare danni materiali.

La staffa interna è #4-40 (UNC).

3. RS-232C/RS-485

Connettore RJ-45 con un cavo RS-232C o RS-485.

Nota: Quando si configura la comunicazione RS-485, lo schema dei cavi per alcuni apparati potrebbe richiedere la polarizzazione dal lato del terminale. Questo terminale non richiede nessuna configurazione particolare, perché gestisce automaticamente la polarizzazione.

Numero pin	RS-232C/RS-485		
	Nome segnale	Direzione	Significato
1	RD(RXD)	Ingresso	Ricezione dati (RS-232C)
2	SD(TXD)	Uscita	Invio dati (RS-232C)
3	NC	–	–
4	D1	Ingresso/ Uscita	Trasferimento dati (RS-485)
5	D0	Ingresso/ Uscita	Trasferimento dati (RS-485)
6	RS(RTS)	Uscita	Richiesta di invio
7	NC	–	–
8	SG	–	Massa del segnale
Involucro	FG	–	Massa del telaio (Comune con SG)

4. RS-485

Connettore RJ-45 con un cavo RS-485.

Nota: Quando si configura la comunicazione RS-485, lo schema dei cavi per alcuni apparati potrebbe richiedere la polarizzazione dal lato del terminale. Questo terminale non richiede nessuna configurazione particolare, perché gestisce automaticamente la polarizzazione

Numero pin	RS-485		
	Nome segnale	Direzione	Significato
1	NC	–	–
2	NC	–	–
3	NC	–	–
4	Linea A	Ingresso/ Uscita	Trasferimento dati (RS-485)
5	Linea B	Ingresso/ Uscita	Trasferimento dati (RS-485)
6	RS(RTS)	Uscita	Richiesta di invio
7	NC	–	connessione assente
8	SG	–	Massa del segnale

1. Requisiti per l'installazione

- Stabilire lo spessore della parete dell'involucro, in base al livello di sforzo richiesto: da 1,6 mm (0,06 in.) a 5 mm (0,2 in.).
- Verificare che il pannello di installazione o la superficie del cabinet sia piatta, in buone condizioni e non abbia bordi seghettati.
- Anche se lo spessore del pannello è nell'intervallo consigliato da "Dimensioni apertura pannello", il pannello potrebbe deformarsi, a seconda del materiale e della dimensione del pannello e della posizione di installazione di Magelis GTO o di altri dispositivi. Per evitare la deformazione del pannello, la superficie di installazione potrebbe richiedere un rinforzo.
- Assicurarsi che la temperatura aria circostante e che l'umidità ambientale siano contenuti negli intervalli definiti.

Temperatura aria circostante:

da 0 a 50 °C (da 32 a 122 °F): HMIGTO1300/1310, HMIGTO2300, HMIGTO3510.

da 0 a 55 °C (da 32 a 131 °F): HMIGTO2310/2315, HMIGTO4310, HMIGTO5310/5315, HMIGTO6310/6315.

Umidità ambientale: da 10 a 90%RH; temperatura bulbo umido: massimo 39 °C (102 °F). Quando si installa il Magelis GTO in un cabinet o in un involucro, la temperatura aria circostante è la temperatura interna del cabinet o dell'involucro.

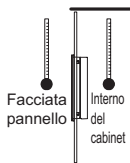

- Assicurarsi che il calore proveniente da apparati circostanti non causi a Magelis GTO di superare la temperatura standard di funzionamento.
- Quando si monta il Magelis GTO in posizione verticale, assicurare che il lato destro del pannello sia rivolto in alto. In altre parole, il connettore di alimentazione per il modello CC dovrebbe essere sulla sommità.

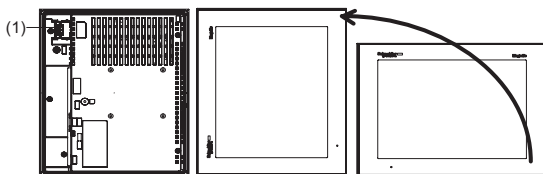

(1) Connettore di alimentazione

- Quando si installa il Magelis GTO in posizione obliqua, la facciata del Magelis GTO non dovrebbe essere inclinata più di 30°.

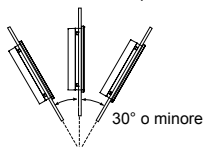

- Quando si installa il Magelis GTO in posizione obliqua con inclinazione maggiore di 30°, la temperatura ambiente non deve superare 40 °C (104 °F). Potrebbe essere necessario l'uso di aria di raffreddamento forzata (ventilatori, A/C) per assicurare che la temperatura ambiente sia al massimo 40°C (massimo 104 °F).
- Per facilitare la manutenzione, il funzionamento e migliorare la ventilazione, installare il Magelis GTO a distanza di 100 mm (3,94 in.) da ogni struttura o da altri apparati adiacenti, come mostrato nell'illustrazione seguente.

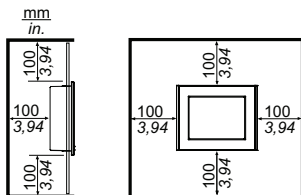

- I fori sul retro del Magelis GTO (eccetto HMIGTO1300/1310) non sono corrispondenti a quelli standard VESA 75mm. Non fissare il Magelis GTO a un braccio VESA di tipo commerciale.

2. Procedura di installazione(ecetto HMIGTO2315/5315/6315)

AVVISO

PANNELLO INSTABILE SE NON È FISSATO

Mantenere il Magelis GTO stabile nell'apertura del pannello mentre si installano o si rimuovono i dispositivi di fissaggio dell viti.

Il mancato rispetto delle istruzioni potrebbe provocare danni materiali.

Passo	Azione
1	Appoggiare il Magelis GTO su una superficie pulita e piana con il display rivolto in basso.
2	<p>Verificare che la guarnizione del Magelis GTO sia insediata stabilmente nella scanalatura apposita che gira intorno al perimetro del telaio del pannello.</p> <p>Nota: Si consiglia vivamente di utilizzare la guarnizione di installazione, per assorbire vibrazioni e per respingere l'acqua. Per la procedura di sostituzione della guarnizione di installazione, far riferimento al "Manuale utente del Magelis GTO".</p>

- 3 Creare un'apertura nel pannello e inserirvi il Magelis GTO dalla parte anteriore.

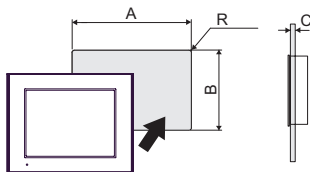

HMIGTO1300/1310

A	B	C	R
118,5 ⁺¹ ₋₀ mm (4,67 ^{+0.04} ₋₀ in.)	92,5 ⁺¹ ₋₀ mm (3,64 ^{+0.04} ₋₀ in.)	1,6...5 mm (0,06...0,2 in)	3 mm (0,12 in.) massimo

HMIGTO2300/2310

A	B	C	R
156 ⁺¹ ₋₀ mm (6,14 ^{+0.04} ₋₀ in.)	123,5 ⁺¹ ₋₀ mm (4,86 ^{+0.04} ₋₀ in.)	1,6...5 mm (0,06...0,2 in)	3 mm (0,12 in.) massimo

HMIGTO3510/HMIGTO4310

A	B	C	R
204,5 ⁺¹ ₋₀ mm (8,05 ^{+0.04} ₋₀ in.)	159,5 ⁺¹ ₋₀ mm (6,28 ^{+0.04} ₋₀ in.)	1,6...5 mm (0,06...0,2 in)	3 mm (0,12 in.) massimo

HMIGTO5310

A	B	C	R
259 ⁺¹ ₋₀ mm (10,2 ^{+0.04} ₋₀ in.)	201 ⁺¹ ₋₀ mm (7,91 ^{+0.04} ₋₀ in.)	1,6...5 mm (0,06...0,2 in)	3 mm (0,12 in.) massimo

HMIGTO6310

A	B	C	R
301,5 ⁺¹ ₋₀ mm (11,87 ^{+0.04} ₋₀ in.)	227,5 ⁺¹ ₋₀ mm (8,96 ^{+0.04} ₋₀ in.)	1,6...5 mm (0,06...0,2 in)	3 mm (0,12 in.) massimo

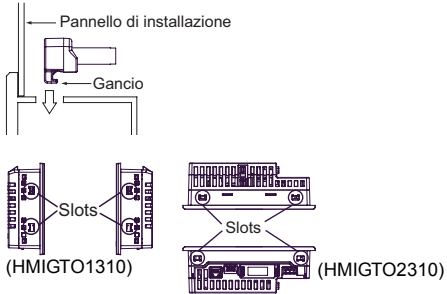
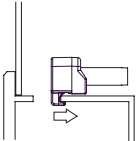
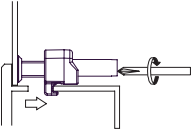
<p>4</p>	<p>Inserire i dispositivi di fissaggio nelle fessure di inserimento del Magelis GTO sui lati superiore e inferiore (lati sinistro e destro per HMIGTO1300/1310). Se i dispositivi di fissaggio non sono attaccati correttamente, il Magelis GTO potrebbe spostarsi o cadere.</p>  <p>Pannello di installazione</p> <p>Gancio</p> <p>Slots</p> <p>(HMIGTO1310)</p> <p>Slots</p> <p>(HMIGTO2310)</p>
<p>5</p>	<p>Far scorrere i dispositivi di fissaggio sul retro.</p> 
<p>6</p>	<p>Usare un cacciavite per stringere tutte le viti dei dispositivi di fissaggio e assicurare il Magelis GTO in posizione. La coppia necessaria è 0,5 Nm (4,4 lb-in).</p> 

AVVISO

INVOLUCRO ROTTO

- Non esercitare più di 0,5 Nm (4,4 in-lb) di coppia per stringere le viti dei dispositivi di fissaggio.
- Utilizzare sulla superficie piatta di un involucro Tipo 1, Tipo 4X (solo uso interno) o Tipo 13

Il mancato rispetto delle istruzioni potrebbe provocare danni materiali.

3. Procedura di rimozione (eccetto HMIGTO2315/5315/6315)

Passo	Azione
1	Allentare i dispositivi di fissaggio (4) del Magelis GTO.
2	Rimuovere il Magelis GTO lentamente dal pannello mentre si premono le sporgenze superiori del Magelis GTO.

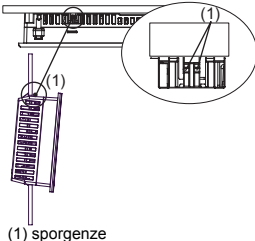

(1) sporgenze

Nota:

- Si potrebbe danneggiare il Magelis GTO se si tenta di rimuoverlo senza tenere abbassate le sporgenze.
- Attenzione alle dita, perché non restino impigliate mentre si tengono abbassate le sporgenze.

⚠ ATTENZIONE

RISCHIO DI LESIONI

Non far cadere il Magelis GTO mentre si rimuove dal pannello.

- Sostenere il Magelis GTO al suo posto mentre si rimuovono i dispositivi di fissaggio.
- Usare entrambe le mani.

Il mancato rispetto delle istruzioni potrebbe provocare lesioni minori o danni materiali.

4. Procedura di installazione (HMIGTO2315/5315/6315)

⚠ ATTENZIONE

RISCHIO DI LESIONI

Non far cadere il Magelis GTO mentre si installa e si rimuove dal pannello.

- Sostenere il Magelis GTO al suo posto mentre si rimuovono i dadi esagonali M4 e le staffe.
- Usare entrambe le mani.

Il mancato rispetto delle istruzioni potrebbe provocare lesioni minori o danni materiali.

AVVISO

PANNELLO INSTABILE SE NON È FISSATO

• Mantenere il Magelis GTO stabile nell'apertura del pannello mentre si installano o si rimuovono i dadi esagonali M4 e le staffe.

Il mancato rispetto delle istruzioni potrebbe provocare danni materiali.

Passo	Azione
1	Appoggiare il Magelis GTO su una superficie pulita e piana con il display rivolto in basso.
2	Verificare che la guarnizione del Magelis GTO sia insediata correttamente sul retro del Magelis GTO.

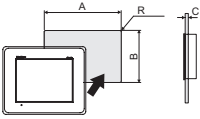
Passo	Azione																								
3	<p data-bbox="222 152 844 203">Creare un'apertura nel pannello e inserirvi il Magelis GTO dalla parte anteriore.</p>  <p data-bbox="217 385 367 407">HMIGTO2315</p> <table border="1" data-bbox="217 414 875 546"> <thead> <tr> <th>A</th> <th>B</th> <th>C</th> <th>R</th> </tr> </thead> <tbody> <tr> <td>195⁺¹₋₀ mm (7,68^{+0.04}₋₀ in.)</td> <td>162,5⁺¹₋₀ mm (6,40^{+0.04}₋₀ in.)</td> <td>1,6...5 mm (0,06...0,2 in)</td> <td>3 mm (0,12 in.) massimo</td> </tr> </tbody> </table> <p data-bbox="217 589 367 611">HMIGTO5315</p> <table border="1" data-bbox="217 618 875 749"> <thead> <tr> <th>A</th> <th>B</th> <th>C</th> <th>R</th> </tr> </thead> <tbody> <tr> <td>298⁺¹₋₀ mm (11,73^{+0.04}₋₀ in.)</td> <td>240⁺¹₋₀ mm (9,45^{+0.04}₋₀ in.)</td> <td>1,6...5 mm (0,06...0,2 in)</td> <td>3 mm (0,12 in.) massimo</td> </tr> </tbody> </table> <p data-bbox="217 771 367 793">HMIGTO6315</p> <table border="1" data-bbox="217 800 875 931"> <thead> <tr> <th>A</th> <th>B</th> <th>C</th> <th>R</th> </tr> </thead> <tbody> <tr> <td>340,5⁺¹₋₀ mm (13,41^{+0.04}₋₀ in.)</td> <td>266,5⁺¹₋₀ mm (10,49^{+0.04}₋₀ in.)</td> <td>1,6...5 mm (0,06...0,2 in)</td> <td>3 mm (0,12 in.) massimo</td> </tr> </tbody> </table>	A	B	C	R	195 ⁺¹ ₋₀ mm (7,68 ^{+0.04} ₋₀ in.)	162,5 ⁺¹ ₋₀ mm (6,40 ^{+0.04} ₋₀ in.)	1,6...5 mm (0,06...0,2 in)	3 mm (0,12 in.) massimo	A	B	C	R	298 ⁺¹ ₋₀ mm (11,73 ^{+0.04} ₋₀ in.)	240 ⁺¹ ₋₀ mm (9,45 ^{+0.04} ₋₀ in.)	1,6...5 mm (0,06...0,2 in)	3 mm (0,12 in.) massimo	A	B	C	R	340,5 ⁺¹ ₋₀ mm (13,41 ^{+0.04} ₋₀ in.)	266,5 ⁺¹ ₋₀ mm (10,49 ^{+0.04} ₋₀ in.)	1,6...5 mm (0,06...0,2 in)	3 mm (0,12 in.) massimo
A	B	C	R																						
195 ⁺¹ ₋₀ mm (7,68 ^{+0.04} ₋₀ in.)	162,5 ⁺¹ ₋₀ mm (6,40 ^{+0.04} ₋₀ in.)	1,6...5 mm (0,06...0,2 in)	3 mm (0,12 in.) massimo																						
A	B	C	R																						
298 ⁺¹ ₋₀ mm (11,73 ^{+0.04} ₋₀ in.)	240 ⁺¹ ₋₀ mm (9,45 ^{+0.04} ₋₀ in.)	1,6...5 mm (0,06...0,2 in)	3 mm (0,12 in.) massimo																						
A	B	C	R																						
340,5 ⁺¹ ₋₀ mm (13,41 ^{+0.04} ₋₀ in.)	266,5 ⁺¹ ₋₀ mm (10,49 ^{+0.04} ₋₀ in.)	1,6...5 mm (0,06...0,2 in)	3 mm (0,12 in.) massimo																						

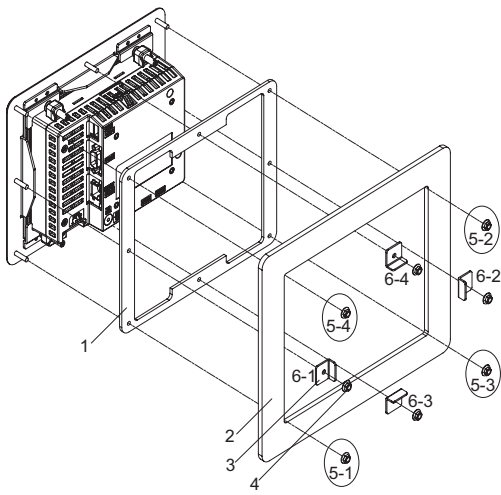
Passo	Azione
<p>4</p>	<p>Inserire il Magelis GTO nell'apertura del pannello.</p>  <p>1 Guarnizione 2 Pannello 3 Staffe 4 M4 Dadi esagonali 5 Leggere il Passo 5. 6 Leggere il Passo 6.</p>
<p>5</p>	<p>Stringere i quattro angoli sul retro del Magelis GTO con i dadi esagonali M4, nell'ordine mostrato nell'esempio al Passo 4. Utilizzare un cacciavite a bussola M4 per stringere tutti i dadi esagonali M4 e assicurare il Magelis GTO in posizione. La coppia necessaria è 0,5 Nm (4,4 lb-in). Se i dadi esagonali M4 non sono fissati correttamente, il Magelis GTO potrebbe spostarsi o cadere.</p>

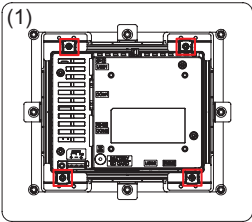
Passo	Azione
6	<p>Fissare la staffa sulle viti, nel mezzo dei dadi esagonali M4, nell'ordine mostrato nell'esempio al Passo 4.</p> <p>Utilizzare un cacciavite a bussola M4 per stringere tutti i dadi esagonali M4 e assicurare il Magelis GTO in posizione. La coppia necessaria è 0,5 Nm (4,4 lb-in). Se i dadi esagonali M4 non sono fissati correttamente, il Magelis GTO potrebbe spostarsi o cadere.</p>
7	<p>Stringere tutti i dadi esagonali M4 di nuovo. La coppia necessaria è 0,5 Nm (4,4 lb-in).</p> <p>Nota: Non allentare i dispositivi di fissaggio dell'installazione segnati con i quadrati qui sotto.</p> <div data-bbox="239 489 566 776" style="text-align: center;">  <p>(1)</p> </div> <p>1 Pannello</p>

AVVISO

INVOLUCRO ROTTO

- Non esercitare più di 0,5 Nm (4,4 in-lb) di coppia per stringere i dadi esagonali M4.
- Utilizzare sulla superficie piatta di un involucro Tipo 1, Tipo 4X (solo uso interno) o Tipo 13

Il mancato rispetto delle istruzioni potrebbe provocare danni materiali.

AVVERTIMENTO

INTERFERENZE ELETTROMAGNETICHE ECCESSIVE

- Quando il terminale (FG) di massa funzionale è collegato, assicurarsi che il cavo sia a massa. La mancanza della messa a massa del Magelis GTO può causare eccessive interferenze elettromagnetiche (EMI). La messa a terra è necessaria per assicurare l'immunità del livello EMC.
- Rimuovere tutte le alimentazioni dal dispositivo prima di rimuovere qualche elemento del sistema e prima di installare o rimuovere qualsiasi accessorio, hardware o cavi.
- Rimuovere l'alimentazione prima di collegare i morsetti del Magelis GTO.
- Il modello CC utilizza solo alimentazione a 24 VCC. Utilizzando altri livelli di alimentazione si potrebbe danneggiare sia l'alimentatore che il Magelis GTO.
- Poiché il Magelis GTO non è dotato di interruttore, assicurarsi di collegare un interruttore all'alimentatore.
- Assicurarsi di mettere il terminale FG del Magelis GTO a massa.
- Sostituire e rendere sicuri tutti gli elementi del sistema prima di alimentare il Magelis GTO.

Il mancato rispetto delle istruzioni potrebbe provocare lesioni gravi o danni materiali.

Nota: La massa dello schermo (SG) e i terminali FG sono connessi internamente al Magelis GTO.

Collegare il cavo di alimentazione CC

Utilizzare esclusivamente conduttori in rame.

Temperatura nominale dei conduttori installati su campo: 75 solo °C (167 °F).

Diametro del cavo di alimentazione	da 0,75 a 2,5 mm ² (18-13 AWG)
Tipo di conduttore	Cavo semplice o intrecciato*1
Lunghezza conduttore	

*1 Se i cavi (singoli) terminali del conduttore non sono ritorti correttamente, i cavi terminali potrebbero far cortocircuito tra loro o contro un elettrodo.

Specifiche del connettore di alimentazione

HMIGTO1300/1310 /
HMIGTO2300/2310/2315 /
HMIGTO3510/4310

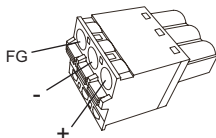

HMIGTO5310/5315 /
HMIGTO6310/6315

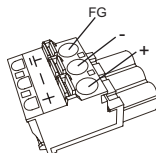

Connessione	Cavo
+	24 VCC
-	0 VCC
FG	Terminale a massa collegato al telaio del pannello.

Come collegare il cavo di alimentazione CC

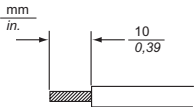
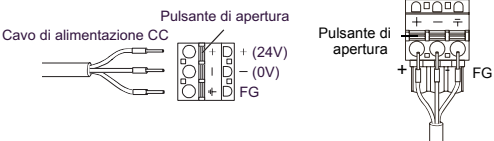
Passo	Azione
1	Verificare che il cavo di alimentazione non sia collegato all'alimentatore.
2	Verificare la tensione nominale e rimuovere l'adesivo "DC24V" sul connettore dell'alimentatore CC.
3	Rimuovere 10 mm (0,39 in.) della membrana vinilica dalle estremità dei fili del cavo di alimentazione. 
4	Se si utilizza un cavo intrecciato, attorcigliare le estremità. Stagnare le estremità per ridurre il rischio che si sfilaccino e garantire una buona conduzione elettrica.
5	Spingere il pulsante di apertura con un cacciavite piccolo e piatto per aprire il foro del pin desiderato.
6	Inserire ogni terminale pin nel suo sostegno corrispondente. Rilasciare il pulsante di apertura per assicurare il pin in posizione. HMIGTO1300/1310 / HMIGTO2300/2310/2315 / HMIGTO3510 / HMIGTO4310 HMIGTO5310/5315 / HMIGTO6310/6315 
7	Dopo aver inserito tutti i tre pin, inserire il connettore dell'alimentatore CC nel connettore di alimentazione del Magelis GTO.

Nota:

- Non saldare il cavo direttamente sul pin del ricettacolo di alimentazione.
- Per evitare la possibilità di un cortocircuito del terminale, utilizzare un terminale pin che abbia un manicotto di isolamento.

- È possibile collegare il connettore dell'alimentatore CC per HMIGTO1300/1310, HMIGTO2300/2310/2315, HMIGTO3510 o HMIGTO4310 su HMIGTO5310/5315 o su HMIGTO6310/6315. Ad ogni modo non è possibile l'inverso. Non è possibile collegare il connettore dell'alimentatore CC per HMIGTO5310/5315 o HMIGTO6310/6315 su HMIGTO1300/1310, HMIGTO2300/2310/2315, HMIGTO3510 o su HMIGTO4310.

Precauzioni nel cablaggio

Miglioramento del rumore/Resistenza di sovracorrente

- Il cavo di alimentazione del Magelis GTO non dovrebbe essere avvolto o tenuto vicino alle linee principali del circuito (alta tensione, alta corrente), alle linee di ingresso/uscita e i loro vari sistemi dovrebbero essere tenuti separati. Se le linee di alimentazione non possono essere collegate su un sistema separato, utilizzare cavi schermati per le linee di ingresso/uscita.
- Realizzare il cavo di alimentazione più corto possibile e assicurarsi di attorcigliare le estremità dei fili tra loro (cioè creare un doppino) vicino all'alimentatore.
- Se fosse presente eccessiva quantità di rumore sulla linea dell'alimentatore, collegare un transistor di riduzione rumore prima di accendere l'alimentazione.
- Collegare uno scaricatore per gestire le sovracorrenti. Assicurarsi di mettere a massa lo scaricatore (E1) separatamente dal Magelis GTO (E2).

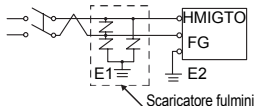

Prevenzione di cortocircuito

- La SG (massa del segnale) e i terminali FG (massa funzionale) sono collegati internamente nel Magelis GTO. Quando si collega la linea SG a un altro dispositivo, assicurarsi di non formare anelli di cortocircuito.

Messa a terra

- Utilizzare un cavo di massa esclusivo, con una resistenza di massa di 100Ω o minore e un cavo di 2mm^2 (AWG 14) o più spesso, oppure gli standard applicativi delle norme locali.

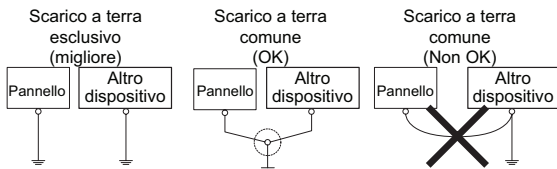

Morsetto serracavo USB

Se si utilizza un dispositivo USB, attaccare un morsetto serracavo USB all'interfaccia USB per evitare che il cavo USB si possa scollegare.

⚠ AVVERTIMENTO

RISCHIO DI ESPLOSIONE IN UBICAZIONI PERICOLOSE

- Verificare che l'alimentazione e i cavi di ingresso/uscita (I/O) siano conformi ai metodi di cablaggio della Classe I, Divisione 2.
- Non sostituire i componenti che indeboliscono la conformità alla Classe I, Divisione 2.
- Verificare che il cavo USB sia stato fissato con il morsetto serracavo USB prima di utilizzare l'interfaccia USB.
- Rimuovere l'alimentazione prima di attaccare e staccare qualsiasi connettore a/dal pannello.

Il mancato rispetto delle istruzioni potrebbe provocare lesioni gravi o danni materiali.

1. Attaccare il morsetto serracavo USB Tipo A

Nota: Attenzione alle dita. Il bordo della molla è affilato.

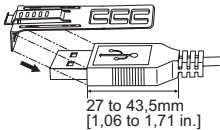
Passo	Azione
1	<p>Montare la molla sulla protezione del connettore sul segno USB  in modo che si sovrapponga. La molla corrisponde alla lunghezza da 27 a 43,5mm [1,06 a 1,71 inch] del connettore USB.</p>  <p>27 to 43,5mm [1,06 to 1,71 in.]</p>

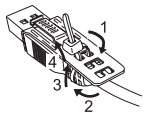
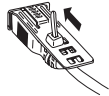
2	<p>Allineare la molla e la protezione del connettore del cavo USB. Regolare la posizione dei fori in cui si attacca la molla. Per garantire la stabilità, scegliere la posizione molla-foro più vicina alla base della protezione del connettore.</p> 
3	<p>Come illustrato, far passare il legame attraverso il foro della molla. Poi ruotare il legame e farlo passare attraverso la testa in modo che il cavo USB possa passare attraverso il centro dell'anello del legame. La molla ora è attaccata al cavo USB.</p>  <p>Nota:</p> <ul style="list-style-type: none"> • Verificare la direzione della testa in anticipo. Assicurarsi che il cavo USB sia dentro al centro dell'anello del fermo e che il fermo possa passare attraverso la testa. • È possibile sostituire il fermo della confezione o i fermi disponibili in commercio con uno di larghezza 4,8 mm [0,19 inch] e spessore 1,3 mm [0,05 inch].
4	<p>Mentre si preme l'impugnatura sulla molla, inserire il cavo al Passo 3 completamente nell'interfaccia host USB. Assicurarsi che la linguetta della molla sia assicurata sul cavo USB attaccato al Magelis GTO.</p> 

2. Rimuovere il cavo USB Tipo A

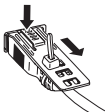
Passo	Azione
1	Rimuovere il cavo USB mentre si spinge la sezione dell'impugnatura della molla. 

3. Attaccare il morsetto serracavo USB mini-B

Nota: Attenzione alle dita. Il bordo della molla è affilato.

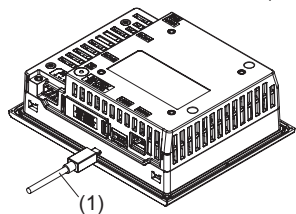
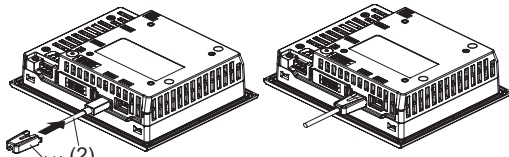
Passo	Azione
1	Inserire il cavo USB nell'interfaccia USB (mini-B).  1 cavo USB
2	Attaccare il sostegno USB per fissare il cavo USB in posizione. Inserire il sostegno USB nell'interfaccia USB (mini-B).  1 sostegno USB 2 cavo USB

4. Rimuovere il sostegno USB

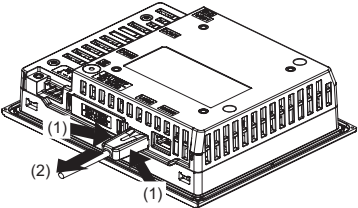
Passo	Azione
1	<p data-bbox="215 200 819 224">Rimuovere il sostegno USB premendo le alette per i lati.</p>  <p data-bbox="215 515 394 564">1 sostegno USB 2 cavo USB</p>

Standard applicabili

La registrazione del N° di modello è come segue:

- HMIGTO1300
- HMIGTO1310
- HMIGTO2300
- HMIGTO2310
- HMIGTO2315
- HMIGTO3510
- HMIGTO4310
- HMIGTO5310
- HMIGTO5315
- HMIGTO6310
- HMIGTO6315

Il Magelis GTO viene prodotto in conformità con:

- Standard UL 508 e CSA C22.2 n°142 per apparati di controllo industriale

Nota:

- Da usare in ambienti con inquinamento Grado 2.
 - Da utilizzare sulla superficie piatta di un involucro Tipo 1, Tipo 4X (solo uso interno) o Tipo 13
 - Il pannello di ingresso 24CC deve essere utilizzato con un alimentatore Classe 2.
 - Da utilizzare in Classe I, Divisione2, solo in ubicazioni a rischio.
- Standard ANSI/ISA - 12.12.01 e CSA C22.2 n°213 per apparati elettrici da usare in Classe I, Divisione 2 ubicazioni a rischio
 - Certificazione GOST.
Far riferimento alle marcature del prodotto.
 - Certificazione ATEX, eseguita da Technical Inspection Association.
Far riferimento all'etichetta del prodotto.
 - Regole della Marina Mercantile. (tranne che per Magelis GTOxxx5.)
I prodotti sono progettati per essere conformi con le regole della Marina Mercantile.
Far riferimento al sito Web della Schneider Electric per le direttive di installazione secondo le regole della Marina Mercantile.
 - Standard EN1672-2 (Magelis GTOxxx5).
 - Regolamento FDA 21 CFR 177 (Magelis GTOxxx5).

⚠ AVVERTIMENTO

RISCHIO DI ESPLOSIONE IN UBICAZIONI PERICOLOSE

- Verificare che l'alimentazione e i cavi di ingresso/uscita (I/O) siano conformi ai metodi di cablaggio della Classe I, Divisione 2.
- Non sostituire i componenti che indeboliscono la conformità alla Classe I, Divisione 2.
- Non collegare o scollegare apparati senza aver prima spento l'alimentazione o in assenza di pericoli locali.
- Non scollegare mentre il circuito è in funzione.
- Bloccare saldamente le unità collegate esternamente e tutte le interfacce prima di accendere l'alimentatore.
- Non utilizzare, collegare o scollegare cavi USB, a meno che si conosca l'area come non è pericolosa.
- Pericolo di carica elettrostatica potenziale: strofinare il pannello frontale del terminale con un panno umido prima di accenderlo.

Il mancato rispetto delle istruzioni potrebbe provocare lesioni gravi o danni materiali.

ATTENZIONE

PERICOLO AMBIENTALE DELL'APPARATO

- Consentire al dispositivo di raggiungere la temperatura dell'aria circostante, non superando i valori seguenti, prima di accendere il dispositivo.
50°C (122°F): HMIGTO1300/1310, HMIGTO2300, HMIGTO3510.
55°C (131°F): HMIGTO2310/2315, HMIGTO4310, HMIGTO5310/5315, and HMIGTO6310/HMIGTO6315.
- Non accendere il dispositivo se è presente della condensa all'interno. Dopo che si è asciugata completamente, il dispositivo potrà essere acceso.
- Non esporre il dispositivo a luce solare diretta.
- Non ostruire le prese d'aria dell'involucro del dispositivo.
- Rimuovere la polvere dal dispositivo prima di accenderlo.
- Assicurarsi che i dispositivi di fissaggio di installazione non siano danneggiati. Se necessario sostituirli.
- La batteria principale può essere cambiata solo da personale qualificato.
- Montare il dispositivo in un involucro che incontri il livello IP54 di protezione per la categoria 3G, IP6x per la categoria 3D e i requisiti relativi alle categorie 3G o 3D nelle zone 2/22 (Categoria 3: livello normale di protezione - G: Gas - D: Polvere).

Il mancato rispetto delle istruzioni potrebbe provocare lesioni minori o danni materiali.

Il Magelis GTO deve essere installato, utilizzato e manutenzione eseguita secondo le:

- Standard WEEE, Direttiva 2002/96/EC
- Standard RoHS, Direttiva 2002/95/EC
- Standard RoHS Cina, Standard SJ/T 11363-2006

目录

概述

装箱物品	200
------------	-----

电气规格

1. HMIGTO1300/1310/2300/2310/2315/3510/4310	201
2. HMIGTO5310/5315/6310/6315	202

部件号与功能

1. HMIGTO1300/1310	203
2. HMIGTO2300/2310/2315	204
3. HMIGTO3510/4310	206
4. HMIGTO5310/5315	207
5. HMIGTO6310/6315	208
6. LED 指示	209

接口

串行接口	210
1. 串口的连接	211
2. RS-232C	212
3. RS-232C/RS-485	213
4. RS-485	214

安装

1. 安装需求	215
2. 安装步骤 (HMIGTO2315/5315/6315 除外)	217
3. 取出步骤 (HMIGTO2315/5315/6315 除外)	221
4. 安装步骤 (HMIGTO2315/5315/6315)	222

接线

接线	226
----------	-----

USB 电缆卡扣

USB 电缆卡扣	230
1. 连接 USB A 型电缆夹具	230
2. 取出 USB A 型电缆	231
3. 连接 USB mini-B 型电缆夹具	232
4. 卸下 USB 座	233

标准

相关标准	234
------------	-----

装箱物品

产品的包装中包含下列项目。使用 Magelis GTO 之前，请予以核实：

- 1 Magelis GTO: 1
- 2 安装衬垫：1（附在 Magelis GTO 机器中）
- 3 安装紧固件：每套 4 个
- 4 支架：4
- 5 M4 Hex Nuts: 8
- 6 DC 电源供应连接器：1
- 7 A 型 USB 电缆夹具：1 组（1 个夹子与 1 根带子）
- 8 mini-B 型 USB 电缆夹具：1（1 个固定架）
- 9 Magelis GTO 快速参考指南（即本指南）：1

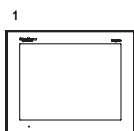

2
对于 HMIGTO2315/5315/6315
除外的 Magelis GTO



对于 HMIGTO2315/5315/6315

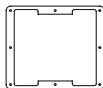

3
对于 HMIGTO2315/5315/6315
除外的 Magelis GTO

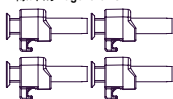

4
对于 HMIGTO2315/5315/6315

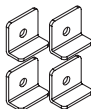

5
对于 HMIGTO2315/5315/6315



6
对于 HMIGTO5310/5315/6310/6315
除外的 Magelis GTO



7

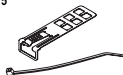

8



对于 HMIGTO5310/5315
对于 HMIGTO6310/6315



我们已经对该面板的包装进行了仔细的质量检查。
如果您发现有损坏或有任何物品损失，请立即与您当地的经销商联系。

1. HMIGTO1300/1310/2300/2310/2315/3510/4310

规格		HMIGTO1300 HMIGTO1310	HMIGTO2300 HMIGTO2310 HMIGTO2315	HMIGTO3510 HMIGTO4310
电源	额定输入电压	24 Vdc		
	输入电压限制	19.2...28.8 Vdc		
	容许瞬时掉电时间	2 毫秒或更低 5 毫秒或更低		
	功耗	9.6W 或更低	10.5W 或更低	12W 或更低
	当外部设备不需要供电时	5.2W 或更低	6.5W 或更低	8W 或更低
	背景灯关闭 (备用模式)	4.2W 或更低	4.5W 或更低	5W 或更低
	背景灯模糊 (亮度: 20%)	4.3W 或更低	5W 或更低	5.5W 或更低
浪涌电流	30A 或更低			
绝缘耐压	1,000 Vac, 20 mA 一分钟 (电源端与 FG 端之间)			
绝缘电阻	500 Vdc, 10 MW 或更多 (电源端与 FG 端之间)			

2. HMIGTO5310/5315/6310/6315

规格		HMIGTO5310/HMIGTO5315/ HMIGTO6310/HMIGTO6315
参数	额定输入电压	24 Vdc
	输入电压限制	19.2...28.8 Vdc
	容许瞬时掉电时间	10 毫秒或更低
	功耗	17W 或更低
	当外部设备不需要供电时	12W 或更低
	背景灯关闭 (备用模式)	7W 或更低
	背景灯模糊 (亮度: 20%)	8W 或更低
浪涌电流		30A 或更低
绝缘耐压		1,000 Vac, 20 mA 一分钟 (电源端与 FG 端之间)
绝缘电阻		500 Vdc, 10 MW 或更多 (电源端与 FG 端之间)

1. HMIGTO1300/1310

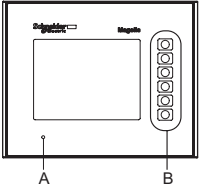
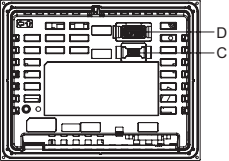
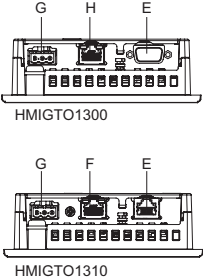
<p>前面</p>	
<p>背面</p>	
<p>底部</p>	 <p>HMIGTO1300</p> <p>HMIGTO1310</p>

- A: 状态 LED 灯 (请参阅页码 209)
- B: 功能开关
- C: USB (mini-B) 接口
- D: USB (A 型) 接口
- E: 串行接口 (COM1)
- F: 以太网接口 (请参阅页码 209)
- G: 电源插头连接器
- H: 串行接口 (COM2)

2. HMIGTO2300/2310/2315

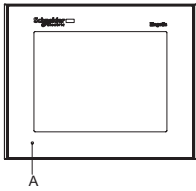
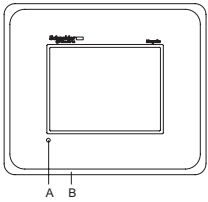
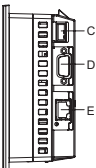
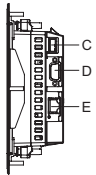
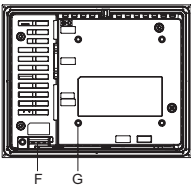
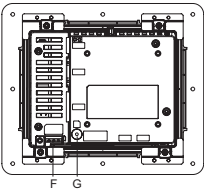
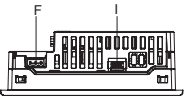
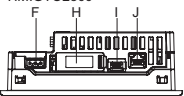
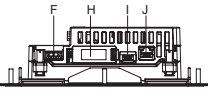
	HMIGTO2300/2310	HMIGTO2315
前面		
右		
背面		
底部	 <p>HMIGTO2300</p>  <p>HMIGTO2310</p>	

- A: 状态 LED 灯 (请参阅页码 209)
- B: 不锈钢表面
- C: USB (A 型) 接口
- D: 串行接口 (COM1)
- E: 串行接口 (COM2) (请参阅页码 209)
- F: 电源插头连接器
- G: SD 卡访问 LED 灯 (请参阅页码 209)^{*1}
- H: SD 卡接口盖 / 备用电池插入盖^{*1}
- I: USB (mini-B) 接口
- J: 以太网接口 (请参阅页码 209)

*1 仅适用于 HMIGTO2310 与 HMIGTO2315。

3. HMIGTO3510/4310

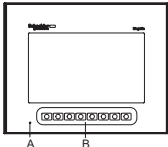
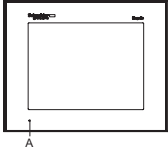
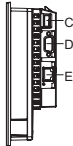
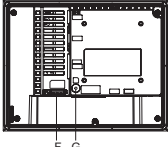
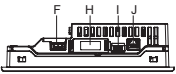

<p>前面</p>	<p>HMIGTO3510</p>  <p>HMIGTO4310</p> 
<p>右</p>	
<p>背面</p>	
<p>底部</p>	

A: 状态 LED 灯 (请参阅页码 209)

B: 功能开关

- C: USB (A 型) 接口
 D: 串行接口 (COM1)
 E: 串行接口 (COM2) (请参阅页码 209)
 F: 电源插头连接器
 G: SD 卡访问 LED 灯 (请参阅页码 209)
 H: SD 卡接口盖 / 备用电池插入盖
 I: USB (mini-B) 接口
 J: 以太网接口 (请参阅页码 209)

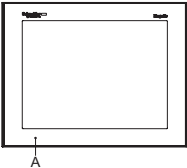
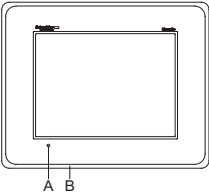
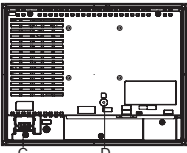
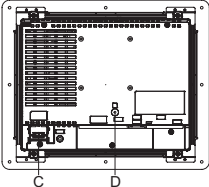

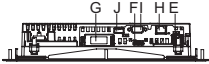
4. HMIGTO5310/5315

	HMIGTO5310	HMIGTO5315
前面		
背面		
底部		

- A: 状态 LED 灯 (请参阅页码 209)
 B: 不锈钢表面
 C: 电源插头连接器
 D: SD 卡访问 LED 灯 (请参阅页码 209)
 E: 以太网接口 (请参阅页码 209)

- F: USB (mini-B) 接口
 G: SD 卡接口盖 / 备用电池插入盖
 H: 串行接口 (COM2)(请参阅页码 209)
 I: 串行接口 (COM1)
 J: USB (A 型) 接口

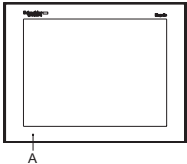
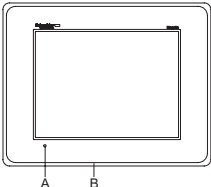
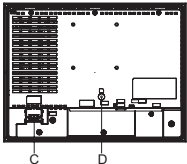
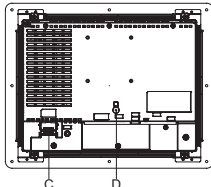
5. HMIGTO6310/6315

	HMIGTO6310	HMIGTO6315
前面		
背面		
底部		

- A: 状态 LED 灯 (请参阅页码 209)
 B: 不锈钢表面
 C: 电源插头连接器
 D: SD 卡访问 LED 灯 (请参阅页码 209)
 E: 以太网接口 (请参阅页码 209)
 F: USB (mini-B) 接口
 G: SD 卡接口盖 / 备用电池插入盖
 H: 串行接口 (COM2)(请参阅页码 209)

I: 串行接口 (COM1)

J: USB (A 型) 接口

6. LED 指示

(1) 状态指示灯

颜色	指示灯	说明
绿色	ON	离线
		操作中
橙色	闪烁	软件启动。
红色	ON	电源接通。
-	OFF	无电源输入。

(2) SD 卡访问 LED

颜色	指示灯	说明
绿色 (活动状态)	ON	SD 卡已插入。
	OFF	SD 卡未插入或不在访问 CF 卡。

(3) 网络 LED

	颜色	指示灯	说明
 <p>链接 启用</p>	绿色 (活动状态)	闪烁	正在进行数据传输。
		OFF	无数据传输
	绿色 (连接状态)	ON	数据传输可用于 10BASE-T/100BASE-TX。
		OFF	无连接或无后续传输。

(4) COM2 LED

颜色	指示灯	说明
黄色	ON	通信 (发送或接收数据) 正在发生。
	OFF	无通信。

串行接口

该串口为非隔离式接口。SG（信号接地）和 FG（机壳接地）端子在面板内部进行连接。



电击

当使用 SG 端子将外部设备连接到本面板时：

- 请确保设置系统时没有建立短路。
- 当您使用 D-Sub 9 针型连接器时，在主设备 (PLC) 未被隔离时，请将 #5 SG 端子连接到远程设备。为减少电路损耗，请将 #5 SG 端子接地。
- 当您使用 RJ-45 连接器时，在主设备 (PLC) 未被隔离时，请将 #8 SG 端子连接到远程设备。为减少电路损耗，请将 #8 SG 端子接地。

如不遵守本说明，将可能会导致人员死亡或重伤。



通信失败

- 请不要给通信端口加太大的压力。
- 将通讯电缆牢固地连接到面板墙或机柜。
- 只使用状况良好、带锁定系统的 9 针 SUB-D 或 RJ45 电缆。

如果未能遵守本说明，可能会导致人身伤害或设备损坏。

1. 串口的连接

每种串口的引脚分配在相关页面中有介绍。

	COM1	COM2
HMIGTO1300	RS-232C (请参阅页码 212)	RS-485 (请参阅页码 214)
HMIGTO1310	RS-232C/RS-485 (请参阅页码 213)	-
HMIGTO2300	RS-232C (请参阅页码 212)	RS-485 (请参阅页码 214)
HMIGTO2310	RS-232C (请参阅页码 212)	RS-485 (请参阅页码 214)
HMIGTO2315	RS-232C (请参阅页码 212)	RS-485 (请参阅页码 214)
HMIGTO3510	RS-232C (请参阅页码 212)	RS-485 (请参阅页码 214)
HMIGTO4310	RS-232C (请参阅页码 212)	RS-485 (请参阅页码 214)
HMIGTO5310	RS-232C (请参阅页码 212)	RS-485 (请参阅页码 214)
HMIGTO5315	RS-232C (请参阅页码 212)	RS-485 (请参阅页码 214)
HMIGTO6310	RS-232C (请参阅页码 212)	RS-485 (请参阅页码 214)
HMIGTO6315	RS-232C (请参阅页码 212)	RS-485 (请参阅页码 214)

2. RS-232C

连在 RS-232C 电缆上的 D-Sub 9 针公头接口。

引脚号	RS-232C		
	信号名称	方向	含义
1	CD	输入	载波检测
2	RD(RXD)	输入	接收数据
3	SD(TXD)	输出	发送数据
4	ER(DTR)	输出	数据端子已就绪
5	SG	-	接地信号
6	DR(DSR)	输入	数据集已就绪
7	RS(RTS)	输出	要发送的请求
8	CS(CTS)	输入	可能会发送
9	CI(RI)/VCC	输入 /-	振铃指示 +5V ± 5% 输出 0.25A
外壳	FG	-	框架地 (通常和 SG 相连)

- 您可以通过软件来改变引脚 #9 的 RI/VCC 选择。

声明

设备损坏

使用额定电流。

如果未能遵守本说明，可能会导致设备损坏。

定位支架是 #4-40 (UNC)。

3. RS-232C/RS-485

连在 RS-232C 或 RS-485 电缆上的 RJ-45 连接器。

注：当设置 RS-485 通信时，某些设备的接线图中终端位置可能需要极化。终端会自动处理极化，故不需要任何特殊设置。

引脚号	RS-232C/RS-485		
	信号名称	方向	含义
1	RD(RXD)	输入	数据接收 (RS-232C)
2	SD(TXD)	输出	数据发送 (RS-232C)
3	NC	—	—
4	D1	输入 / 输出	数据传输 (RS-485)
5	D0	输入 / 输出	数据传输 (RS-485)
6	RS(RTS)	输出	要发送的请求
7	NC	—	—
8	SG	—	接地信号
外壳	FG	—	框架地 (通常和 SG 相连)

4. RS-485

连在 RS-485 电缆上的 RJ-45 连接器。

注：当设置 RS-485 通信时，某些设备的接线图中终端位置可能需要极化。终端会自动处理极化，故不需要任何特殊设置。

引脚号	RS-485		
	信号名称	方向	含义
1	NC	-	-
2	NC	-	-
3	NC	-	-
4	A 线路	输入 / 输出	数据传输 (RS-485)
5	B 线路	输入 / 输出	数据传输 (RS-485)
6	RS(RTS)	输出	要发送的请求
7	NC	-	无连接
8	SG	-	接地信号

1. 安装需求

- 根据外墙的厚度以及厚度的级别：1.6 mm (0.06 in.) 至 5 mm (0.2 in.)。
- 检查安装面板或机柜的表面是否平坦、状况良好且无参差不齐的边缘。
- 即使面板厚度在“面板开口尺寸”推荐的范围内，根据面板的材质、尺寸及安装位置的不同，面板也可能有弯折。为防止面板弯折，请加强安装表面。
- 请确保周围环境的空气温度和湿度都在合适范围内。

环境空气温度

0 至 50 ° C (32 至 122 ° F):HMIGTO1300/1310, HMIGTO2300, HMIGTO3510。

0 至 55 ° C (32 至 131 ° F):HMIGTO2310/2315, HMIGTO4310, HMIGTO5310/5315, HMIGTO6310/6315。

工作环境湿度：10 到 90%RH；湿球温度计：最大值 39 ° C (102 ° F)。

当在机柜或机箱中安装 Magelis GTO 时，“工作环境温度”是指机柜或机箱的内部温度。

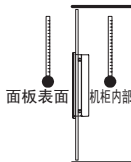

- 确保周围设备的散热不会导致 Magelis GTO 超出标准工作温度。
- 当将 Magelis GTO 垂直安装时，请将面板的右侧朝上放置。即，DC 电源连接器需要朝上放置。

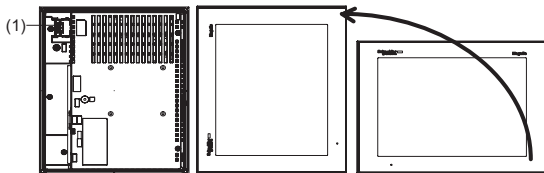

(1) 电源连接器

- 在倾斜的面板上安装 Magelis GTO 时，面板表面的倾斜度不得超过 30°。

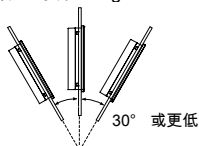

- 当在倾斜度超过 30° 的面板上安装 Magelis GTO 时，请确保周围的温度不能超过 40° C (104° F)。您可能需要使用空调或电扇来降温以确保操作温度控制在 40° C (104° F) 或以下。
- 为方便维护、操作和更好地通风，安装时请在 Magelis GTO 与相邻物体及其他设备间至少留出 100 毫米 [3.94 英寸] 的空隙，如下图所示：

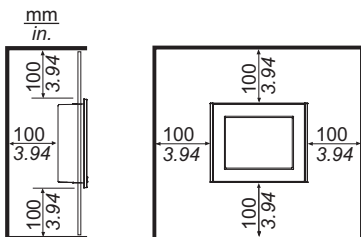

- Magelis GTO (HMIGTO1300/1310 除外) 后板上的孔不符合 VESA 75mm 标准。请不要将 Magelis GTO 连接在商用型 VESA 控制臂上。

2. 安装步骤 (HMIGTO2315/5315/6315 除外)

声明

在未固定的情况下面板不稳定

当您正在安装或取出螺钉起子时将 Magelis GTO 稳定固定在面板开孔内。

如果未能遵守本说明，可能会导致设备损坏。

步骤	操作
1	请将 Magelis GTO 放置在平整的表面上，并使面板朝下。
2	请检查安装垫圈已稳妥地插入 Magelis GTO 四周的垫圈凹槽中。 注： 衬垫除具有防水功能外还可吸收振动，因此强烈建议您使用安装衬垫。 关于更换安装衬垫的步骤，请参阅“Magelis GTO 用户手册”。

- 3** 在面板上开一个孔，将 Magelis GTO 从前板插入到面板中。

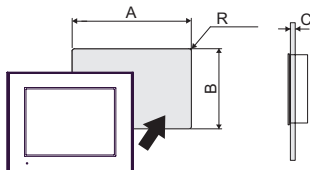

HMIGTO1300/1310

A	B	C	R
118.5 ⁺¹ ₋₀ 毫米 (4.67 ^{+0.04} ₋₀ in.)	92.5 ⁺¹ ₋₀ 毫米 (3.64 ^{+0.04} ₋₀ in.)	1.6...5 mm (0.06...0.2 in)	3 mm (0.12 in.) 最大值

HMIGTO2300/2310

A	B	C	R
156 ⁺¹ ₋₀ 毫米 (6.14 ^{+0.04} ₋₀ in.)	123.5 ⁺¹ ₋₀ 毫米 (4.86 ^{+0.04} ₋₀ in.)	1.6...5 mm (0.06...0.2 in)	3 mm (0.12 in.) 最大值

HMIGTO3510/HMIGTO4310

A	B	C	R
204.5 ⁺¹ ₋₀ 毫米 (8.05 ^{+0.04} ₋₀ in.)	159.5 ⁺¹ ₋₀ 毫米 (6.28 ^{+0.04} ₋₀ in.)	1.6...5 mm (0.06...0.2 in)	3 mm (0.12 in.) 最大值

HMIGTO5310

A	B	C	R
259 ⁺¹ ₋₀ 毫米 (10.2 ^{+0.04} ₋₀ in.)	201 ⁺¹ ₋₀ 毫米 (7.91 ^{+0.04} ₋₀ in.)	1.6...5 mm (0.06...0.2 in)	3 mm (0.12 in.) 最大值

HMIGTO6310

A	B	C	R
301.5 ⁺¹ ₋₀ 毫米 (11.87 ^{+0.04} ₋₀ in.)	227.5 ⁺¹ ₋₀ 毫米 (8.96 ^{+0.04} ₋₀ in.)	1.6...5 mm (0.06...0.2 in)	3 mm (0.12 in.) 最大值

- 4** 将安装螺钉插入 Magelis GTO 的顶部和底部的插孔内 (HMIGTO1300/1310 的左右两边)。如果螺钉没有正确安装的话, Magelis GTO 可能会有移动或翻倒。

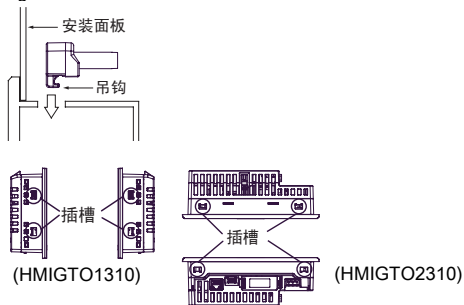

- 5** 将螺钉滑到背部。

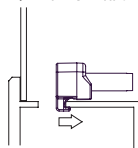

- 6** 使用螺丝刀将每个扣件螺钉拧紧并将 Magelis GTO 固定到位。需要 0.5 Nm (4.4 lb-in) 的力矩：

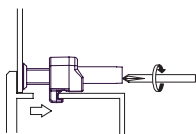

声明

外围损坏

- 拧紧螺钉扣件时，施加的扭矩请勿超过以 0.5 Nm (4.4 in-lb) 的力矩。
- 使用在 Type 1，Type 4X（仅在室内使用）或 Type 13 外壳的光滑表面上。

如果未能遵守本说明，可能会导致设备损坏。

3. 取出步骤 (HMIGTO2315/5315/6315 除外)

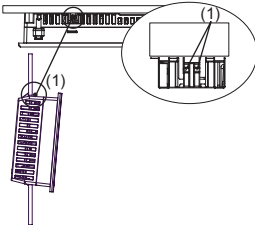
步骤	操作
1	将 Magelis GTO 中的四个安装螺钉拧松。
2	<p>当按下 Magelis GTO 的顶部的凸出部位后，将 Magelis GTO 慢慢从面板中取出。</p>  <p>(1) 凸出部位</p> <p>注：</p> <ul style="list-style-type: none"> • 如果您没有按下凸出部位的按键时，您可能会毁坏 Magelis GTO。 • 当按下凸出部位时，请注意您的手部动作。

⚠ 注意

伤害风险

当您从面板中取出 Magelis GTO 时，请谨防掉落。

- 在取出螺钉后请按住 Magelis GTO。
- 请使用双手。

如果未能遵守本说明，可能会导致人员伤亡或设备损坏。

4. 安装步骤 (HMIGTO2315/5315/6315)

注意

伤害风险

当您从面板中取出 Magelis GTO 时，请谨防掉落。

- 在取出 M4 Hex nuts 与支架后，请把 Magelis GTO 放回原位。
- 请使用双手。

如果未能遵守本说明，可能会导致人员伤亡或设备损坏。

声明

在未固定的情况下面板不稳定

当您正在安装或取出 M4 Hex nuts 与支架时将 Magelis GTO 稳定固定在面板开孔内。

如果未能遵守本说明，可能会导致设备损坏。

步骤	操作
1	请将 Magelis GTO 放置在平整的表面上，并使面板朝下。
2	请确认 Magelis GTO 的支架正确安装在 Magelis GTO 设备的背部。

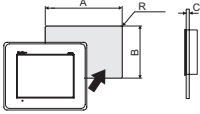
步骤	操作																								
3	<p data-bbox="222 152 870 182">在面板上开一个孔，将 Magelis GTO 从前板插入到面板中。</p>  <p data-bbox="222 371 372 400">HMIGTO2315</p> <table border="1" data-bbox="222 400 882 531"> <thead> <tr> <th>A</th> <th>B</th> <th>C</th> <th>R</th> </tr> </thead> <tbody> <tr> <td>195⁺¹₋₀ 毫米 (7.68^{+0.04}₋₀ in.)</td> <td>162.5⁺¹₋₀ 毫米 (6.40^{+0.04}₋₀ in.)</td> <td>1.6...5 mm (0.06...0.2 in)</td> <td>3 mm (0.12 in.) 最大值</td> </tr> </tbody> </table> <p data-bbox="222 553 372 582">HMIGTO5315</p> <table border="1" data-bbox="222 582 882 713"> <thead> <tr> <th>A</th> <th>B</th> <th>C</th> <th>R</th> </tr> </thead> <tbody> <tr> <td>298⁺¹₋₀ 毫米 (11.73^{+0.04}₋₀ in.)</td> <td>240⁺¹₋₀ 毫米 (9.45^{+0.04}₋₀ in.)</td> <td>1.6...5 mm (0.06...0.2 in)</td> <td>3 mm (0.12 in.) 最大值</td> </tr> </tbody> </table> <p data-bbox="222 735 372 764">HMIGTO6315</p> <table border="1" data-bbox="222 764 882 895"> <thead> <tr> <th>A</th> <th>B</th> <th>C</th> <th>R</th> </tr> </thead> <tbody> <tr> <td>340.5⁺¹₋₀ 毫米 (13.41^{+0.04}₋₀ in.)</td> <td>266.5⁺¹₋₀ 毫米 (10.49^{+0.04}₋₀ in.)</td> <td>1.6...5 mm (0.06...0.2 in)</td> <td>3 mm (0.12 in.) 最大值</td> </tr> </tbody> </table>	A	B	C	R	195 ⁺¹ ₋₀ 毫米 (7.68 ^{+0.04} ₋₀ in.)	162.5 ⁺¹ ₋₀ 毫米 (6.40 ^{+0.04} ₋₀ in.)	1.6...5 mm (0.06...0.2 in)	3 mm (0.12 in.) 最大值	A	B	C	R	298 ⁺¹ ₋₀ 毫米 (11.73 ^{+0.04} ₋₀ in.)	240 ⁺¹ ₋₀ 毫米 (9.45 ^{+0.04} ₋₀ in.)	1.6...5 mm (0.06...0.2 in)	3 mm (0.12 in.) 最大值	A	B	C	R	340.5 ⁺¹ ₋₀ 毫米 (13.41 ^{+0.04} ₋₀ in.)	266.5 ⁺¹ ₋₀ 毫米 (10.49 ^{+0.04} ₋₀ in.)	1.6...5 mm (0.06...0.2 in)	3 mm (0.12 in.) 最大值
A	B	C	R																						
195 ⁺¹ ₋₀ 毫米 (7.68 ^{+0.04} ₋₀ in.)	162.5 ⁺¹ ₋₀ 毫米 (6.40 ^{+0.04} ₋₀ in.)	1.6...5 mm (0.06...0.2 in)	3 mm (0.12 in.) 最大值																						
A	B	C	R																						
298 ⁺¹ ₋₀ 毫米 (11.73 ^{+0.04} ₋₀ in.)	240 ⁺¹ ₋₀ 毫米 (9.45 ^{+0.04} ₋₀ in.)	1.6...5 mm (0.06...0.2 in)	3 mm (0.12 in.) 最大值																						
A	B	C	R																						
340.5 ⁺¹ ₋₀ 毫米 (13.41 ^{+0.04} ₋₀ in.)	266.5 ⁺¹ ₋₀ 毫米 (10.49 ^{+0.04} ₋₀ in.)	1.6...5 mm (0.06...0.2 in)	3 mm (0.12 in.) 最大值																						

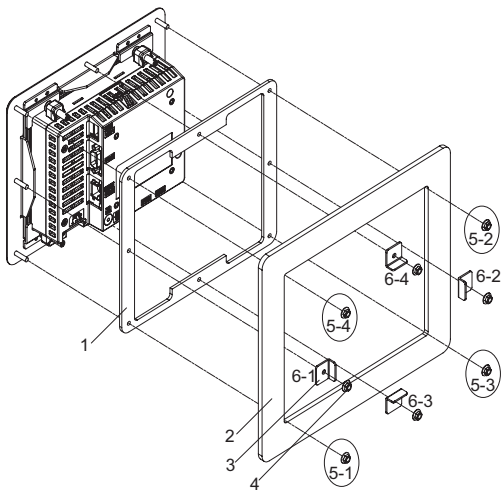
步骤	操作
<p>4</p>	<p>将 Magelis GTO 插入面板开孔处。</p>  <p>1 垫圈 2 画面 3 支架 4 M4 Hex nuts 5 请阅读步骤 5. 6 请阅读步骤 6.</p>
<p>5</p>	<p>请将带有 M4 Hex nuts 的 Magelis GTO 的背部的四个角进行紧固，如示例中的步骤 4 所示。 请使用 M4 box 型螺丝起子紧固每个 M4 Hex nut 以及把 Magelis GTO 归位。所需力矩是 0.5 Nm (4.4 lb-in)。如果 M4 Hex nut 螺钉没有正确安装的话，Magelis GTO 可能会有移动或翻倒。</p>

步骤	操作
6	<p>将支架装在 M4 Hex nuts 之间，如示例中的步骤四所示。请使用 M4 box 型螺丝起子紧固每个 M4 Hex nut 以及把 Magelis GTO 归位。所需力矩是 0.5 Nm (4.4 lb-in)。如果 M4 Hex nut 螺钉没有正确安装的话，Magelis GTO 可能会有移动或翻倒。</p>
7	<p>请再次紧固 M4 Hex nuts。所需力矩是 0.5 Nm (4.4 lb-in)。 注： 请不要拧松如下图所示的安装螺钉。</p> <div data-bbox="238 378 564 662" style="text-align: center;"> <p>(1)</p> </div> <p>1 画面</p>

声明

外圈损坏

- 拧紧 M4 Hex nuts 螺钉扣件时，施加的扭矩请勿超过 以 0.5 Nm (4.4 in-lb) 的力矩。
- 使用在 Type 1，Type 4X（仅在室内使用）或 Type 13 外壳的光滑表面上。

如果未能遵守本说明，可能会导致设备损坏。

警告

过多的电磁干扰

- 当连接好机壳接地 (FG) 端子后，确保将电线接地。如果 Magelis GTO 不接地，将引起过大的电磁干扰。为了符合良好的电磁兼容性抗扰度，请务必接地。
- 在安装或卸载各种附件、硬件或者电缆之前或移除系统的任何元器件前，请先断开电源。
- 将 Magelis GTO 的电源端子接线时请关闭电源。
- 该 DC 设备仅使用 24Vdc 直流电源供电。使用其他级别的电源可能会损坏电源和 Magelis GTO。
- 由于 Magelis GTO 不带电源开关，请确保先连接一个电源开关后再将电源接入到 OT。
- 请确保将本 Magelis GTO 的 FG 端子接地。
- 替换好部件，并确保该系统的所有盖板与元器件都安装好后，再重新给 Magelis GTO 供电。

如果未能遵守本说明，可能会导致人员死亡、重伤或设备损坏。

注： 屏蔽接地 (SG) 和 FG 端子在 Magelis GTO 内部进行连接。

连接 DC 电源线

仅使用铜导线。

现场安装的导线的额定温度：75 × C (167 × F)。

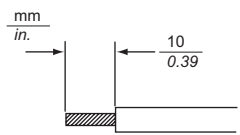
电源线直径	0.75 - 2.5 mm ² (18-13 AWG)
导体类型	简单或标准接线 *1
导体长度	

*1 如果导体末端的金属线缠绕不正确，也会造成末端的相互短路，或者电极短路。

电源接口规格

HMIGTO1300/1310 /
HMIGTO2300/2310/2315 /
HMIGTO3510/4310

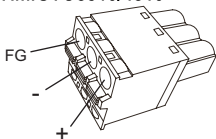

HMIGTO5310/5315 /
HMIGTO6310/6315

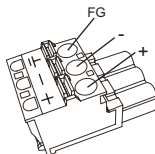

连接	导线
+	24 Vdc
-	0 Vdc
FG	连接到设备外壳的接地端子。

如何连接 DC 电源线

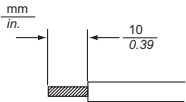
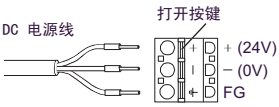
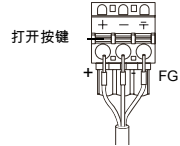
步骤	操作
1	请确认电源线没有连接到电源上。
2	请确认额定电压并移走 DC 电源连接器上的“DC24V”标签。
3	请取下每根电缆中的长为 10 mm (0.39 in.) 的塑料护套。 
4	如果使用的是双绞线，请将电缆末端绞合在一起。请给电缆末端焊锡，这样会减少电缆的磨损，并能保持良好的电流传输效果。
5	请用一个小平头螺丝起子压住打开按键，以打开想要的引脚端口。
6	请把每个引脚终端插入相应的固定口内。请松开打开按键把引脚放置在合适位置。 HMIGTO1300/1310 / HMIGTO2300/2310/2315 / HMIGTO3510 / HMIGTO4310  HMIGTO5310/5315 / HMIGTO6310/6315 
7	在插入三个引脚后，在 Magelis GTO 中的电源插上插入 DC 电源供应连接口。

注：

- 请勿将导线直接焊接到电源插座的引脚上。
- 为了防止终端短路，请使用拥有有隔离套的引脚终端。
- 您可以将 HMIGTO1300/1310、HMIGTO2300/2310/2315、HMIGTO3510 或 HMIGTO4310 中的 DC 电源模块连接到 HMIGTO5310/5315 或 HMIGTO6310/6315。您无法将 HMIGTO5310/5315 或 HMIGTO6310/6315 中的 DC 电源模块连接到 HMIGTO1300/1310、HMIGTO2300/2310/2315、HMIGTO3510 或 HMIGTO4310。

接线注意事项

干扰 / 浪涌阻抗的改进

- Magelis GTO 的电源线不应该绑定或靠近主电流线（高电压 / 高电流 电源线或者输入 / 输出）以及各种系统应保持隔离。当电源线无法通过隔离系统进行接线时，请为输入 / 输出使用屏蔽线。
- 请保持电源线足够短并确保将靠近电源的电缆的末端扭在一起。
- 如果电源端由超大噪音的话请在打开电源前连接一个抗噪音晶体管。
- 请连接雷浪涌吸收器，吸收电源浪涌。确保将电涌吸收器 (E1) 和 Magelis GTO (E2) 分开接地。

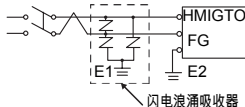

短路阻止

- 屏蔽接地 (SG) 和 (FG 功能接地) 端子在 Magelis GTO 内部进行连接。当将 SG 线连接其他设备时请确保没有短路发生。

接地

- 请使用专用接地线阻抗在 100Ω 或以下，电阻丝在 2mm^2 (AWG 14) 或更粗或者按照您当地的可用标准。

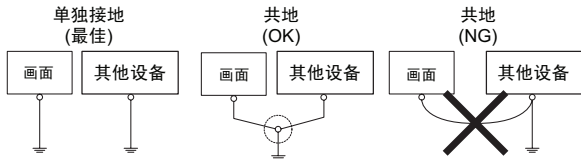

USB 电缆卡扣

请使用 USB 设备 将 USB 电缆夹具连接在 USB 接口以防止 USB 电缆在通信过程中断开。

警告

危险地点的爆炸风险

- 请确认电源 / 输入 / 输出 (I/O) 接线符合 I 类 2 分类的接线方式。
- 请勿替换组件，这可能会违反 I 类 2 分类的相关规定。
- 在使用 USB 接口前请确认 USB 电缆已经牢牢固定在 USB 电缆夹具。
- 把任何连接器连接到面板或从面板中拔下之前，请一定要先关闭电源。

如果未能遵守本说明，可能会导致人员死亡、重伤或设备损坏。

1. 连接 USB A 型电缆夹具

注：操作请注意您的手指，因为夹具的边缘很锋利。

步骤	操作
1	<p>请把夹具装在 USB 标志  连接器外壳使之重叠。夹具与 USB 连接器的长度 27 至 43.5mm [1.06 至 1.71 inch] 相匹配。</p> <p style="text-align: center;">27 to 43.5mm [1.06 to 1.71 in.]</p>
2	<p>请将夹具与 USB 电缆连接器的外壳对齐。当连接夹具时请调整开口处的位置。为了确保稳定性，请选择靠近连接器外壳基座的夹具开口位置。</p> <p style="text-align: center;">从此处绕线</p>

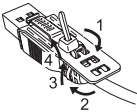
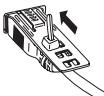
<p>3</p>	<p>如图所示，请通过夹具开口穿线。下一步，把线折回并让它穿过头，使得 USB 电缆可以穿过线圈的中心。夹具现在连接上了 USB 电缆。</p>  <p>注：</p> <ul style="list-style-type: none"> • 请首先检查头部的方向。请确保 USB 电缆已通过线圈的中心位置且线可以通过头部位置。 • 您可以使用工具包中的替换线或商用线结 (宽度 4.8 mm [0.19 inch] / 厚度 1.3 mm [0.05 inch])。
<p>4</p>	<p>当按下夹具上的开关时将步骤 3 中的电缆插入 USB 主接口中。请确保夹具已安全插入 Magelis GTO 上连接的 USB 电缆。</p> 

2. 取出 USB A 型电缆

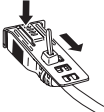
步骤	操作
<p>1</p>	<p>当按下夹子上的开关选择时取出 USB 电缆。</p> 

3. 连接 USB mini-B 型电缆夹具

注：操作请注意您的手指，因为夹具的边缘很锋利。

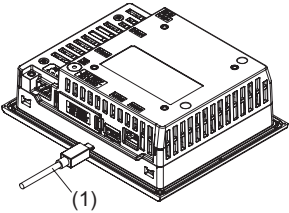
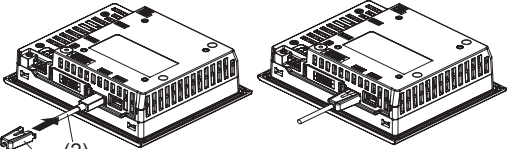
步骤	操作
1	将 USB 电缆插入 USB (mini-B) 接口。  1 USB 电缆
2	加上 USB 座以使 USB 电缆固定到位。将 USB 座插入 USB (mini-B) 接口。  1 USB 座 2 USB 电缆

4. 卸下 USB 座

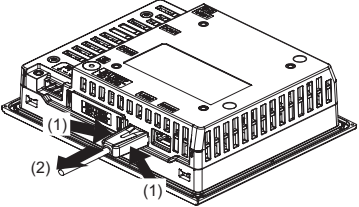
步骤	操作
1	<p data-bbox="217 203 657 225">请通过按下边上的凸出部分取出 USB 座。</p>  <p data-bbox="217 516 341 567">1 USB 座 2 USB 电缆</p>

相关标准

注册型号如下：

- HMIGTO1300
- HMIGTO1310
- HMIGTO2300
- HMIGTO2310
- HMIGTO2315
- HMIGTO3510
- HMIGTO4310
- HMIGTO5310
- HMIGTO5315
- HMIGTO6310
- HMIGTO6315

Magelis GTO 符合：

- 用于工业控制设备的标准 UL 508 与 CSA C22.2 n° 142

注：

- 用在污染程度为 2 的环境中
- 使用在 Type 1, Type 4X (仅在室内使用) 或 Type 13 外壳的光滑表面上。
- 24 Vdc 输入面板必须与一个 Class 2 电源一起使用。
- 仅使用于 Class I, Division 2 危险地点。
- 电子设备 Class I, Division 2 危险场所使用电子设备的标准 ANSI/ISA - 12.12.01 及 CSA C22.2 n° 213
- GOST 认证。
请参阅产品标志。
- 技术检查协会的 ATEX 认证。
请参阅产品标志。
- Merchant Navy 规则。(除 Magelis GTOxxx5)
产品设计为符合 Merchant Navy 规则。
有关 Merchant Navy 规则的安装，请参阅 Schneider Electric 网站。
- 标准 EN1672-2 (Magelis GTOxxx5)。
- FDA 规则 21 CFR 177 (Magelis GTOxxx5)。

警告

危险地点的爆炸风险

- 请确认电源 / 输入 / 输出 (I/O) 接线符合 1 类 2 分类的接线方式。
- 请勿替换组件，这可能会违反 1 类 2 分类的相关规定。
- 除非已拔下电源或确定所在位置无危险，否则请勿连接设备或断开设备的连接。
- 当电路运行时请不要断开。
- 在打开电源供应时安全锁住外部连接设备和各个接口。
- 请不要使用连接或断开连接 USB 电缆，除非地处非危险地带。
- 潜在电器负荷危险：请开启前用抹布擦拭前面板。

如果未能遵守本说明，可能会导致人员死亡、重伤或设备损坏。

注意

对环境危害

- 允许设备达到环境温度儿不超出以下数值：
 - 50° C (122° F):HMIGTO1300/1310, HMIGTO2300, HMIGTO3510。
 - 55° C (55.00° C):HMIGTO2310/2315, HMIGTO4310, HMIGTO5310/5315, 及 HMIGTO6310/HMIGTO6315。
- 若设备内部有冲突的话请不要打开设备在完全干透的情况下打开设备。
- 请不要把设备直接暴露在太阳底下。
- 请不要遮住设备的出风口。
- 请在打开设备之前给设备除灰。
- 请确保电缆安装紧固件没有损坏。如有需要请予以替换。
- 仅限有资格人员可以更改主要电池。
- 安装设备时请遵照 3G 类 IP54 级保护 ,3D 类 IP6x 级保护以及 3G 或 3D 类的相关需求 (处在 3 类正常保护级别 - G: 大气 - D: 灰尘)。

如果未能遵守本说明，可能会导致人身伤害或设备损坏。

Magelis GTO 必须遵照以下标准进行安装 / 使用 / 维护：

- Standard WEEE, Directive 2002/96/EC
- Standard RoHS, Directive 2002/95/EC
- Standard RoHS China, Standard SJ/T 11363-2006



部件名称

产品中有毒有害物质或元素的名称及含量

铅

汞

镉

六价铬

多溴联苯

多溴二苯醚

人机界面产品

X

X

O

O

O

O

O：表示该有毒有害物质在该部件所有均质材料中的含量均在 SJ/T11363-2006 标准规定的限量要求以下。

X：表示该有毒有害物质至少在该部件的某一均质材料中的含量超出 SJ/T11363-2006 标准规定的限量要求。

本表显示了施耐德电气供应链的电子信息技术产品中可能包含的物质。

注意：自销售之日起，所售产品中可能包含，也可能不包含上述物质。

S1B6463 00

Schneider Electric

Headquarters

35 rue Joseph Monier
F - 92506 Rueil Malmaison Cedex

<http://www.schneider-electric.com>

Owing to changes in standards and equipment,
the characteristics given in the text and images
in this document are not bound by us and are
subject to change.



* S 1 B 6 4 6 4 3 0 0 *

Copyright © 1/2012 Schneider Electric

Printed in China
PFX128099F .HMIGTO-MT01-BTH 2012.01 SS/A