

STI Wire Guard Damage Stopper®

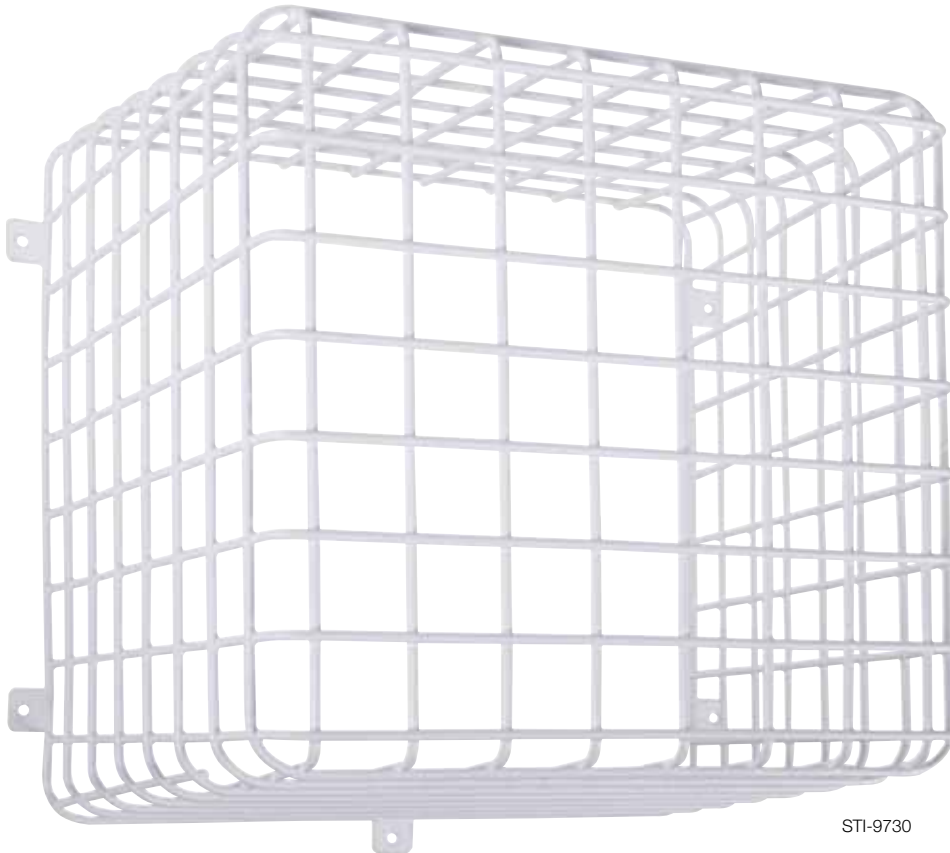

STI-9730

PRODUCT OVERVIEW

This member of the STI Wire Guard Team was created in response to multiple requests from STI customers. The STI-9730 is constructed of 9-gauge steel wire coated with corrosion resistant polyester. The size and sturdy steel construction make the Multi Use Damage Stopper an easy choice for protecting a wide variety of sensitive equipment.

FEATURES

- Guard protects a wide variety of devices against theft and vandalism.
- Constructed of 9-gauge coated steel wire.
- Fast and easy installation with all screws and anchors provided.
- May be spray painted once prior to installation to match decor.
- Three year guarantee against breakage in normal use.

STI Wire Guard Damage Stopper®

Dimensions and Technical Information

MODELS AVAILABLE

STI-9730 Wire Guard Damager Stopper

WARRANTY

Three year guarantee against breakage in normal use.

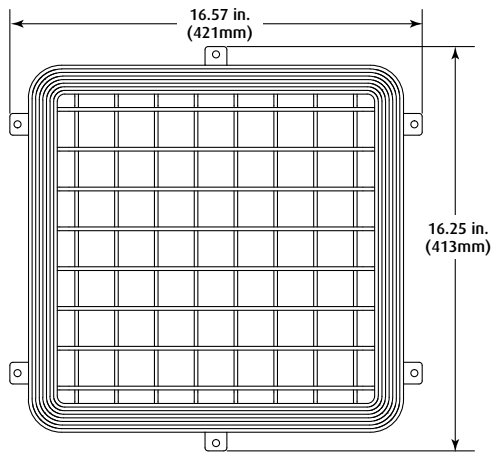

EXTERNAL DIMENSIONS

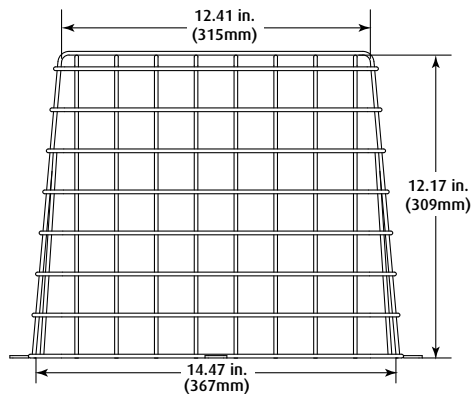

INTERNAL DIMENSIONS



**Safety Technology
International, Inc.**

2306 Airport Road
Waterford, Michigan
48327, USA

Tel: 248-673-9898
Fax: 248-673-1246
Toll-free: 800-888-4784
info@sti-usa.com
www.sti-usa.com

Unit 49G Pipers Road
Park Farm Industrial Estate
Redditch, Worcestershire
B98 0HU England

Tel: 44 (0) 1527 520 999
Fax: 44 (0) 1527 501 999
Free: 0800 085 1678 (UK)
www.sti-europe.com