

NAUTILAIR

Model: 150642-00P

MECHANICAL

DIAMETER: 12.3" (312mm)
DISCHARGE TYPE: Tangential
DISCHARGE: Standard Rectangular Flange
APPROXIMATE WEIGHT: 28lbs/12.7kg

PERFORMANCE

FLOW CLASSIFICATION: High Energy
STAGES: 1 Stage

TEMPERATURE

OPERATING TEMP: 0°C to 50°C
STORAGE TEMP: -40°C to 85°C

ELECTRICAL

OPERATING INPUT VOLTAGE: RANGE: 180-264 VAC
OPERATING INPUT VOLTAGE: 240V

OPTIONAL FEATURES

SPEED CONTROL: PWM Pull Up, Open Loop, 4-Pin Power, 5-Pin Control, 3-Pin Status

REGULATORY CERTIFICATIONS

COMPLIANCE: RoHS and Reach
UL FILE NUMBER: E94403
AGENCY FULL LOAD AMPS: 30A

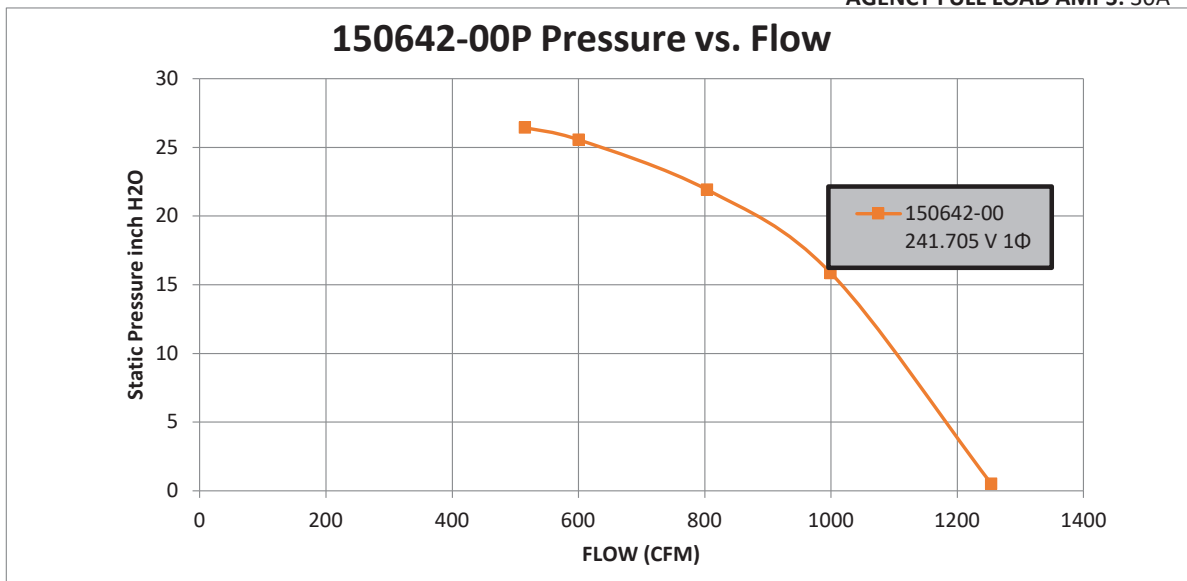

Flow Rate <i>cfm</i>	Static Pressure <i>inch H2O</i>	Total Pressure <i>inch H2O</i>	Current <i>A</i>	Power Demand <i>W</i>	Voltage <i>V</i>	Flow Temp. <i>°C</i>	Rotational Speed <i>rpm</i>	Static Efficiency <i>%</i>	Total Efficiency <i>%</i>
1254.13	0.50	1.31	22.94	3668.54	241.71	26.45	7620	2.05	5.32
999.97	15.82	16.33	24.99	4002.16	241.73	27.99	8700	47.31	48.83
804.13	21.90	22.23	22.93	3651.93	241.61	28.78	9150	57.80	58.67
600.63	25.54	25.73	20.40	3214.99	242.38	29.50	9510	57.31	57.72
515.85	26.41	26.54	19.19	2994.57	243.03	29.99	9690	54.69	54.97

WARNING

DESIGN APPLICATION: Designed to provide variable airflow for low NOx and CO emission in high efficiency gas fired combustion systems. Built with non-sparking materials. Blower housing assembly constructed of die cast aluminum. Impeller constructed from hardened aluminum. Rubber isolation mounts built into blower construction to dampen vibration within the motor. Two-piece blower housing assembly sealed, and factory leak checked. Customer is responsible to check for any leakage once the blower is installed into the final application.

MISCELLANEOUS: Motor cooling inlet and discharge vents must not be obstructed. Motor ventilation air to be free of oils and other foreign particles. Blower is to be mounted so ventilation air cannot be re-circulated.

NOTES:

1. RoHS AND REACH COMPLIANCE. REFERENCE AMETEK ENVIRONMENTAL SPECIFICATION ES0010 FOR DETAILS.
2. **POWER CONNECTION:** BLOWER CONNECTOR, MATES WITH CUSTOMER SUPPLIED MOLEX CONNECTOR PN#172672-2004 WITH FEMALE TERMINALS, PN#171825 OR EQUIVALENT ON 12GA WIRE.
3. **CONTROL CONNECTION:** BLOWER CONNECTOR, MATES WITH CUSTOMER SUPPLIED MOLEX SERIES 5557 CONNECTOR HOUSING, (PN#39-01-4051) WITH FEMALE TERMINALS, (PN#39-00-0208) OR EQUIVALENT ON 22GA, 125°, 300V WIRE.
4. **STATUS OUTPUT CONNECTOR:** BLOWER CONNECTOR, MATES WITH CUSTOMER SUPPLIED MOLEX CONNECTOR PN#50-29-1662 WITH FEMALE TERMINALS, PN#39-00-0214 OR EQUIVALENT ON 22GA WIRE.
5. ALL INTAKE, EXHAUST, COOLING DUCTS AND VENTS MUST NOT BE OBSTRUCTED BY MOUNTING.
6. MOTOR VENTILATION AIR TO BE FREE OF OILS AND OTHER FOREIGN PARTICLES, (I.E. BREATHING QUALITY AIR). BLOWER TO BE MOUNTED SO THAT MOTOR VENTILATION AIR CANNOT RECIRCULATE.
7. TACH OUTPUT-2 PULSES PER REVOLUTION. SIGNAL IS A FREQUENCY (Hz) INDICATOR OF THE RPM CAN BE MEASURED WITH RESPECT TO GROUND (PIN 5). RPM=TACH. OUT x 30.

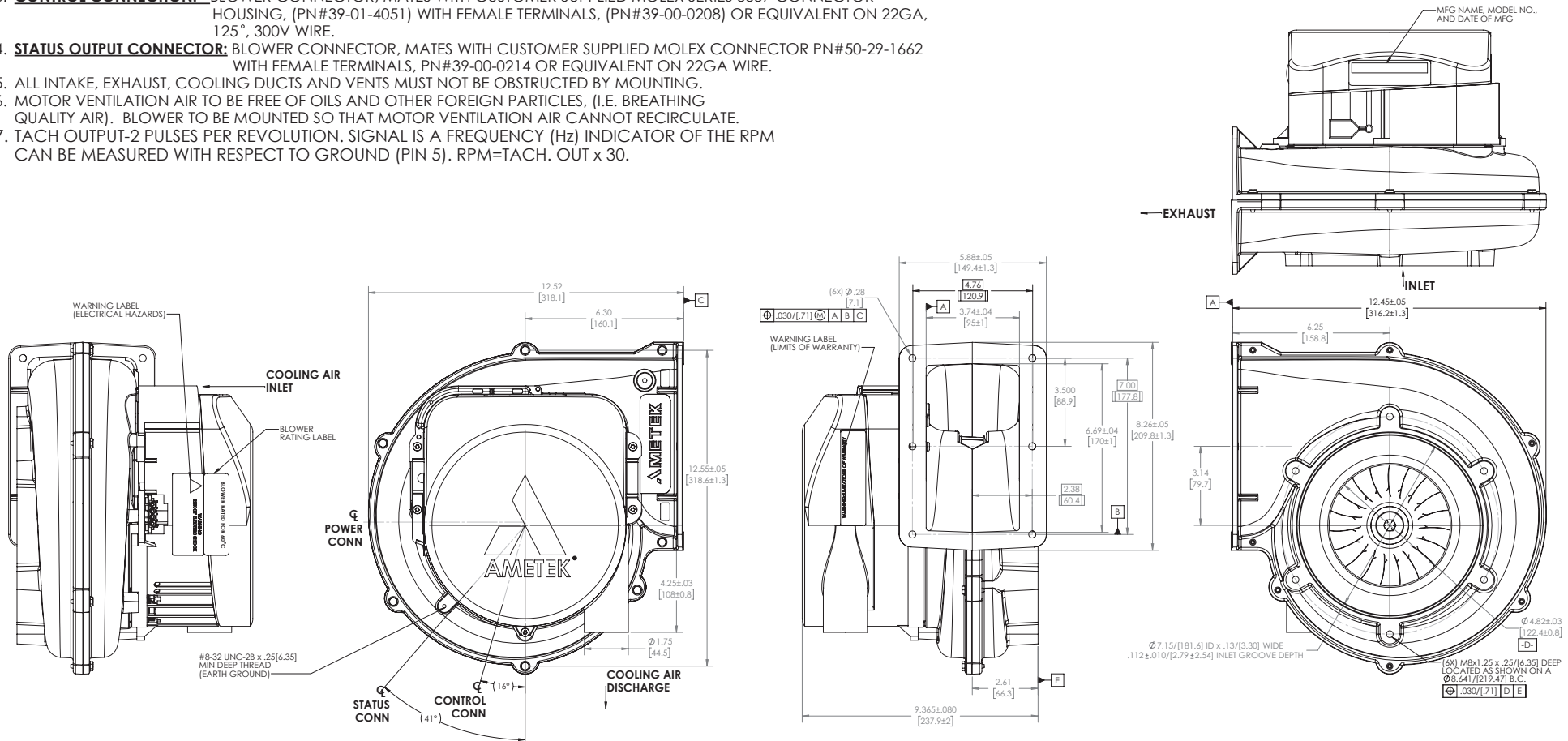

8500-02-00
PWM PULLED UP



POWER CONNECTION

PIN #	CONTROL	DESCRIPTION	COLOR
1	-	GROUND	GREEN
2	-	A/C INPUT	WHITE
3	INPUT	A/C INPUT	WHITE
4	INPUT	A/C INPUT	BLACK



CONTROL CONNECTION

PIN #	CONTROL	DESCRIPTION	COLOR
1	INPUT	15V-40V (OPTIONAL)	RED
2	OUTPUT	TACH OUTPUT	WHITE
3	NOT USED	NOT USED	YELLOW
4	INPUT	PWM(1.5-36V)(1-20kHz)	GREEN
5	INPUT	COMMON	BLACK



STATUS OUTPUT CONNECTION

PIN #	CONTROL	DESCRIPTION	COLOR
1	OUTPUT	ISOLATED +15VDC	RED
2	OUTPUT	OPEN COLLECTOR TRANSISTOR	BLUE
3	OUTPUT	ISOLATED COMMON	BLACK