

Nautilair 150232-16

MECHANICAL

DIAMETER: 8.9" (226mm)
DISCHARGE TYPE: Tangential
DISCHARGE: Standard Square
APPROXIMATE WEIGHT: 7.8lbs/3.5Kg

PERFORMANCE

FLOW CLASSIFICATION: High Output
STAGES: 1 Stage

TEMPERATURE

OPERATING TEMP: 0°C to 50°C
STORAGE TEMP: -40°C to 85°C

ELECTRICAL

OPERATING INPUT VOLTAGE RANGE: 108-132VAC
OPERATING INPUT VOLTAGE: 120VAC

OPTIONAL FEATURES

SPEED CONTROL: PWM, open loop

REGULATORY CERTIFICATIONS

COMPLIANCE: RoHS and Reach
UL FILE NUMBER: E94403

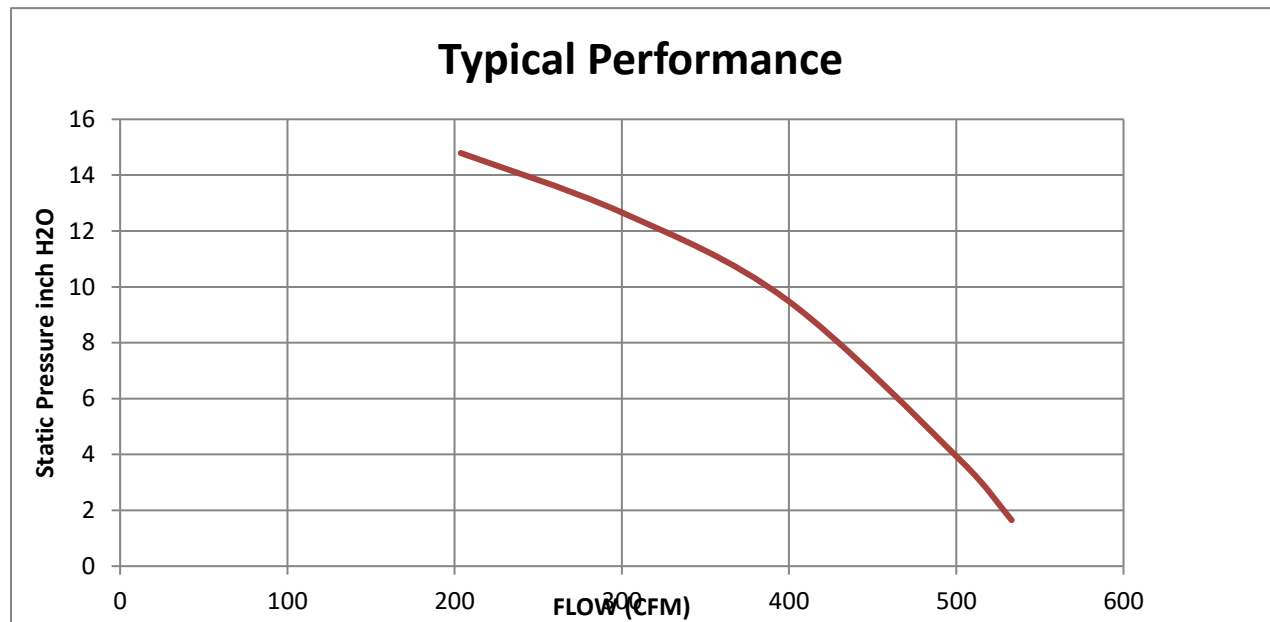

Flow Rate <i>cfm</i>	Total Pressure <i>inch H2O</i>	Current <i>A</i>	Power Demand <i>W</i>	Voltage <i>V</i>	Flow Temp. <i>°C</i>	Rotational Speed <i>rpm</i>	Total Efficiency <i>%</i>
533.11	2.11	15.93	1137.84	119.89	22.86	8760	11.65
503.02	4.17	15.57	1107.86	119.92	23.08	8910	22.36
398.57	9.80	14.07	988.70	120.04	23.55	9390	46.70
300.53	12.80	12.33	858.09	120.17	24.11	9930	53.07
203.66	14.86	10.89	750.03	120.28	24.30	10350	47.81

DESIGN APPLICATION: Designed to provide variable airflow for low NOx and CO emission in high efficiency gas fired combustion systems. Built with non-sparking materials. Blower housing assembly constructed of die cast aluminum. Impeller constructed from hardened aluminum. Rubber isolation mounts built into blower construction to dampen vibration within the motor. Two-piece blower housing assembly sealed, and factory leak checked. Customer is responsible to check for any leakage once the blower is installed into the final application.

MISCELLANEOUS: Motor cooling inlet and discharge vents must not be obstructed. Motor ventilation air to be free of oils and other foreign particles. Blower is to be mounted so ventilation air cannot be re-circulated.

REVISIONS		CHANGE	DATE	APP'D
REV	ECN NO.	RELEASED TO PRODUCTION:	3-29-19	MH
A	DMR #543	MH		

- NOTES:
1. ALL INTAKE, EXHAUST, COOLING DUCTS AND VENTS MUST NOT BE OBSTRUCTED BY MOUNTING.
 2. MOTOR VENTILATION AIR TO BE FREE OF OILS AND OTHER FOREIGN PARTICLES. (I.E. BREATHING AIR QUALITY)
 3. **GROUND LEAD:** GREEN/YELLOW LEAD: MALE TERMINAL AMP PN# 350218-1 ON 18GA. 1015 UL STYLE 105°C. 600V RATED WIRE.
 4. **POWER CONNECTION:** BLOWER CONNECTOR, AMP UNIVERSAL MATE-N-LOK (PN# 350767-1) MATES WITH CUSTOMER SUPPLIED AMP CONNECTOR. (PN# 350766-1) WITH FEMALE TERMINALS. PN# 350536-3 OR EQUIVALENT ON 600V, 105°C, 16GA WIRE.
 5. **CONTROL CONNECTION:** BLOWER CONNECTOR, MOLEX SERIES 5559 (PN# 39-01-4057) MATES WITH CUSTOMER SUPPLIED MOLEX SERIES 5557 CONNECTOR HOUSING. (PN#39-01-4051) WITH FEMALE TERMINALS, (PN# 39-00-0208) OR EQUIVALENT ON 300V, 125°C 22GA. WIRE.
 6. TACH OUTPUT-2 PULSES PER REVOLUTION. SIGNAL IS A FREQUENCY (HZ) INDICATOR OF THE RPM
 7. ROHS AND REACH COMPLIANCE, REFERENCE AMETEK ENVIRONMENTAL SPECIFICATION ES0010 FOR DETAILS.

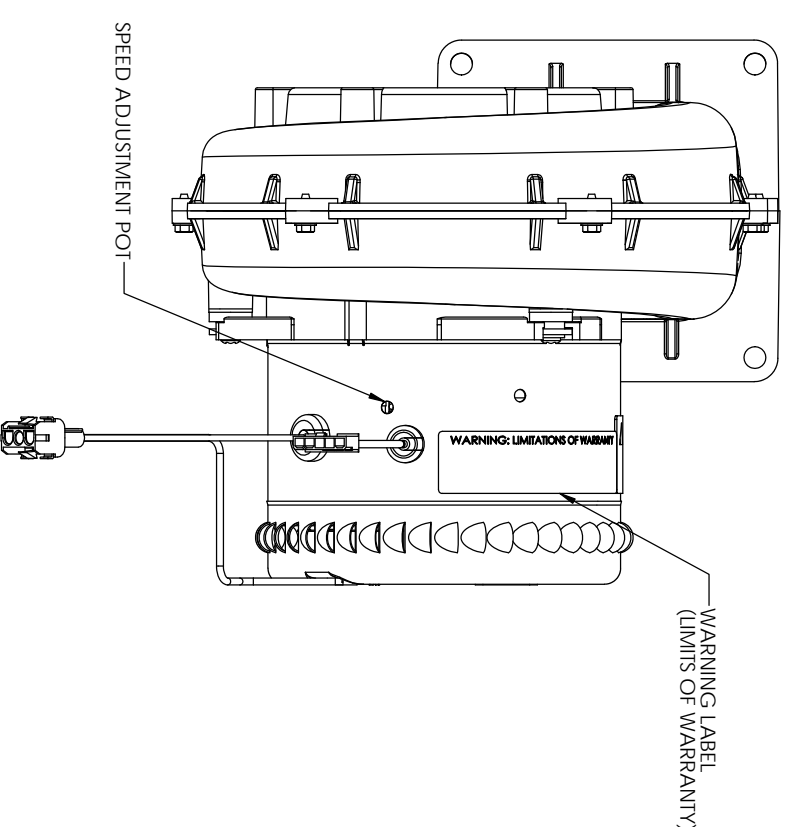
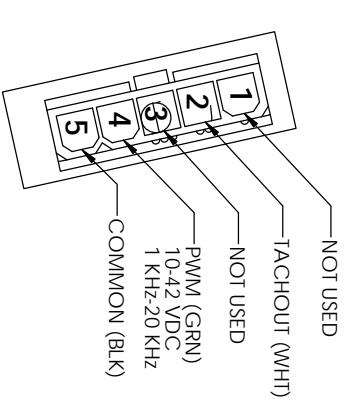
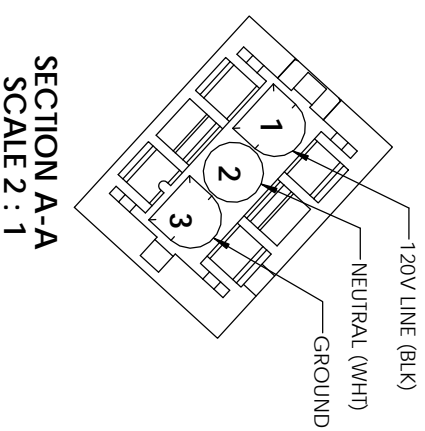
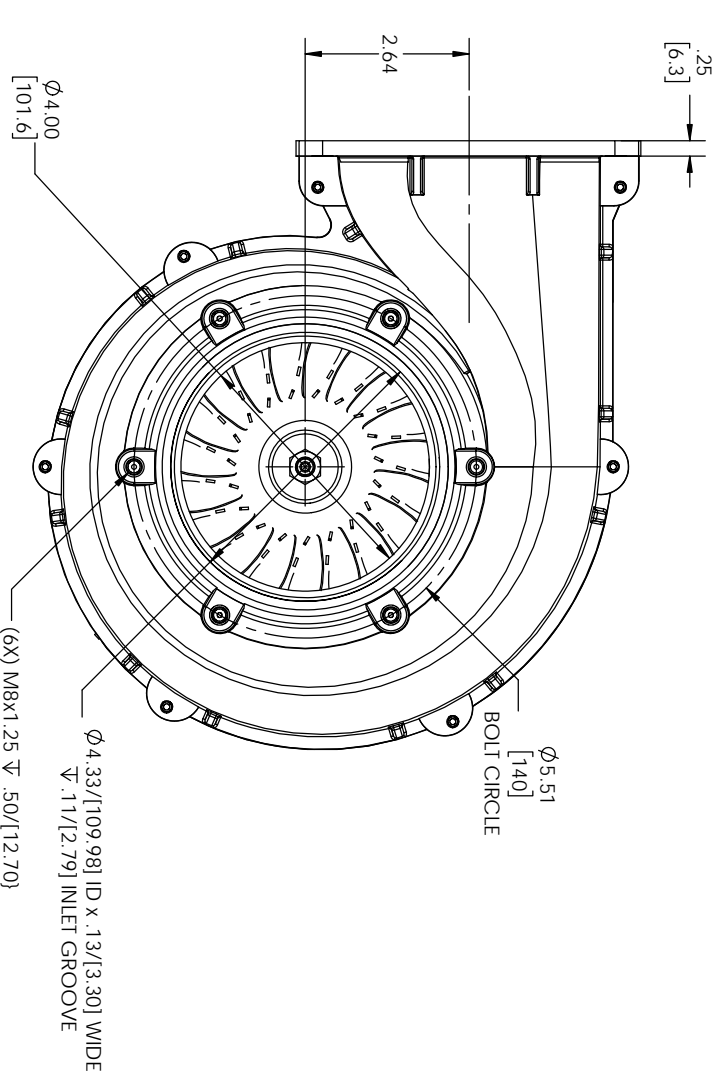
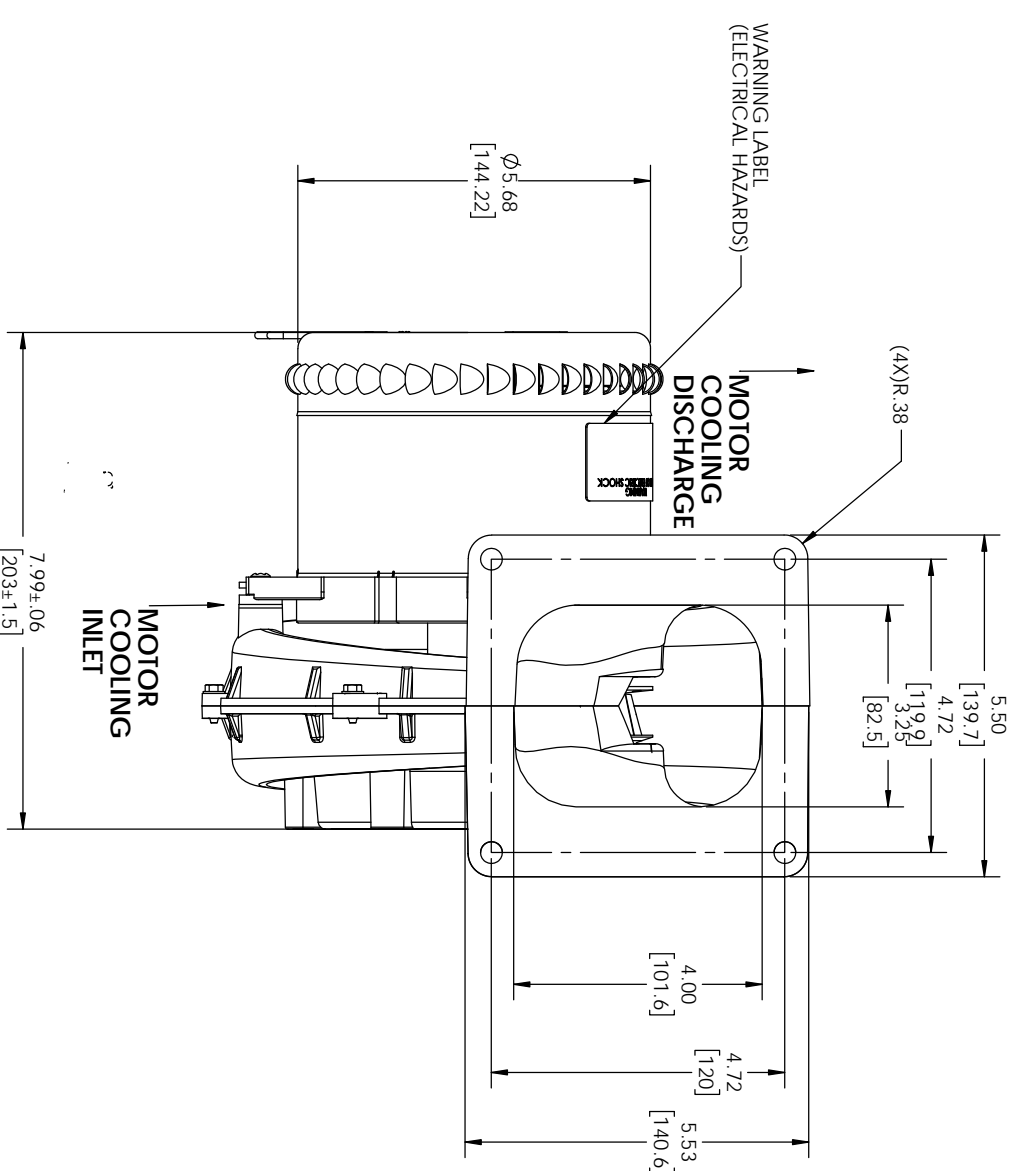
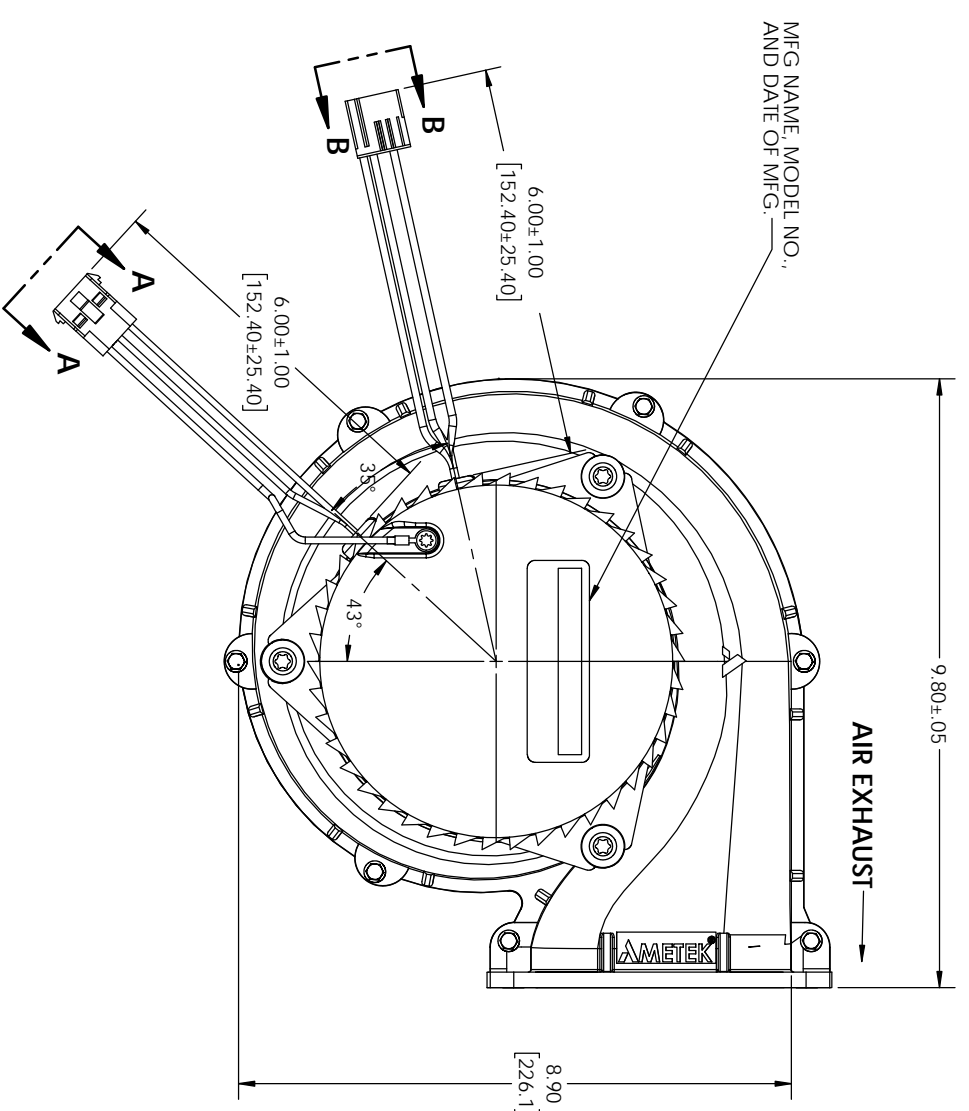

CONFORMS TO THE REQUIREMENTS OF THE ROHS DIRECTIVE

REF: EN60947-2-1

REF: EN60947-1

REF: EN60947-3-1

REF: EN60947-3-2

REF: EN60947-3-3

REF: EN60947-3-4

REF: EN60947-3-5

REF: EN60947-3-6

REF: EN60947-3-7

REF: EN60947-3-8

REF: EN60947-3-9

REF: EN60947-3-10

REF: EN60947-3-11

REF: EN60947-3-12

REF: EN60947-3-13

REF: EN60947-3-14

REF: EN60947-3-15

REF: EN60947-3-16

REF: EN60947-3-17

REF: EN60947-3-18

REF: EN60947-3-19

REF: EN60947-3-20

REF: EN60947-3-21

REF: EN60947-3-22

REF: EN60947-3-23

REF: EN60947-3-24

REF: EN60947-3-25

REF: EN60947-3-26

REF: EN60947-3-27

REF: EN60947-3-28

REF: EN60947-3-29

REF: EN60947-3-30

REF: EN60947-3-31

REF: EN60947-3-32

REF: EN60947-3-33

REF: EN60947-3-34

REF: EN60947-3-35

REF: EN60947-3-36

REF: EN60947-3-37

REF: EN60947-3-38

REF: EN60947-3-39

REF: EN60947-3-40

REF: EN60947-3-41

REF: EN60947-3-42

REF: EN60947-3-43

REF: EN60947-3-44

REF: EN60947-3-45

REF: EN60947-3-46

REF: EN60947-3-47

REF: EN60947-3-48

REF: EN60947-3-49

REF: EN60947-3-50

REF: EN60947-3-51

REF: EN60947-3-52

REF: EN60947-3-53

REF: EN60947-3-54

REF: EN60947-3-55

REF: EN60947-3-56

REF: EN60947-3-57

REF: EN60947-3-58

REF: EN60947-3-59

REF: EN60947-3-60

REF: EN60947-3-61

REF: EN60947-3-62

REF: EN60947-3-63

REF: EN60947-3-64

REF: EN60947-3-65

REF: EN60947-3-66

REF: EN60947-3-67

REF: EN60947-3-68

REF: EN60947-3-69

REF: EN60947-3-70

REF: EN60947-3-71

REF: EN60947-3-72

REF: EN60947-3-73

REF: EN60947-3-74

REF: EN60947-3-75

REF: EN60947-3-76

REF: EN60947-3-77

REF: EN60947-3-78

REF: EN60947-3-79

REF: EN60947-3-80

REF: EN60947-3-81

REF: EN60947-3-82

REF: EN60947-3-83

REF: EN60947-3-84

REF: EN60947-3-85

REF: EN60947-3-86

REF: EN60947-3-87

REF: EN60947-3-88

REF: EN60947-3-89

REF: EN60947-3-90

REF: EN60947-3-91

REF: EN60947-3-92

REF: EN60947-3-93

REF: EN60947-3-94

REF: EN60947-3-95

REF: EN60947-3-96

REF: EN60947-3-97

REF: EN60947-3-98

REF: EN60947-3-99

REF: EN60947-3-100

REF: EN60947-3-101

REF: EN60947-3-102

REF: EN60947-3-103

REF: EN60947-3-104

REF: EN60947-3-105

REF: EN60947-3-106

REF: EN60947-3-107

REF: EN60947-3-108

REF: EN60947-3-109

REF: EN60947-3-110

REF: EN60947-3-111

REF: EN60947-3-112

REF: EN60947-3-113

REF: EN60947-3-114

REF: EN60947-3-115

REF: EN60947-3-116

REF: EN60947-3-117

REF: EN60947-3-118

REF: EN60947-3-119

REF: EN60947-3-120

REF: EN60947-3-121

REF: EN60947-3-122

REF: EN60947-3-123

REF: EN60947-3-124

REF: EN60947-3-125

REF: EN60947-3-126

REF: EN60947-3-127

REF: EN60947-3-128

REF: EN60947-3-129

REF: EN60947-3-130

REF: EN60947-3-131

REF: EN60947-3-132

REF: EN60947-3-133

REF: EN60947-3-134

REF: EN60947-3-135

REF: EN60947-3-136

REF: EN60947-3-137

REF: EN60947-3-138

REF: EN60947-3-139

REF: EN60947-3-140

REF: EN60947-3-141

REF: EN60947-3-142

REF: EN60947-3-143

REF: EN60947-3-144

REF: EN60947-3-145

REF: EN60947-3-146

REF: EN60947-3-147

REF: EN60947-3-148

REF: EN60947-3-149

REF: EN60947-3-150

REF: EN60947-3-151

REF: EN60947-3-152

REF: EN60947-3-153

REF: EN60947-3-154

REF: EN60947-3-155

REF: EN60947-3-156

REF: EN60947-3-157

REF: EN60947-3-158

REF: EN60947-3-159

REF: EN60947-3-160

REF: EN60947-3-161

REF: EN60947-3-162

REF: EN60947-3-163

REF: EN60947-3-164

REF: EN60947-3-165

REF: EN60947-3-166

REF: EN60947-3-167

REF: EN60947-3-168

REF: EN60947-3-169

REF: EN60947-3-170

REF: EN60947-3-171

REF: EN60947-3-172

REF: EN60947-3-173

REF: EN60947-3-174

REF: EN60947-3-175

REF: EN60947-3-176

REF: EN60947-3-177

REF: EN60947-3-178

REF: EN60947-3-179

REF: EN60947-3-180

REF: EN60947-3-181

REF: EN60947-3-182

REF: EN60947-3-183

REF: EN60947-3-184

REF: EN60947-3-185

REF: EN60947-3-186

REF: EN60947-3-187

REF: EN60947-3-188

REF: EN60947-3-189

REF: EN60947-3-190

REF: EN60947-3-191

REF: EN60947-3-192

REF: EN60947-3-193

REF: EN60947-3-194

REF: EN60947-3-195

REF: EN60947-3-196

REF: EN60947-3-197

REF: EN60947-3-198

REF: EN60947-3-199

REF: EN60947-3-200

REF: EN60947-3-201

REF: EN60947-3-202

REF: EN60947-3-203

REF: EN60947-3-204

REF: EN60947-3-205

REF: EN60947-3-206

REF: EN60947-3-207

REF: EN60947-3-208

REF: EN60947-3-209

REF: EN60947-3-210

REF: EN60947-3-211

REF: EN60947-3-212

REF: EN60947-3-213

REF: EN60947-3-214

REF: EN60947-3-215

REF: EN60947-3-216

REF: EN60947-3-217

REF: EN60947-3-218

REF: EN60947-3-219

REF: EN60947-3-220

REF: EN60947-3-221

REF: EN60947-3-222

REF: EN60947-3-223

REF: EN60947-3-224

REF: EN60947-3-225

REF: EN60947-3-226

REF: EN60947-3-227

REF: EN60947-3-228

REF: EN60947-3-229

REF: EN60947-3-230

REF: EN60947-3-231

REF: EN60947-3-232

REF: EN60947-3-233

REF: EN60947-3-234

REF: EN60947-3-235

REF: EN60947-3-236

REF: EN60947-3-237

REF: EN60947-3-238

REF: EN60947-3-239

REF: EN60947-3-240

REF: EN60947-3-241

REF: EN60947-3-242

REF: EN60947-3-243

REF: EN60947-3-244

REF: EN60947-3-245

REF: EN60947-3-246

REF: EN60947-3-247

REF: EN60947-3-248

REF: EN60947-3-249

REF: EN60947-3-250

REF: EN60947-3-251

REF: EN60947-3-252

REF: EN60947-3-253

REF: EN60947-3-254

REF: EN60947-3-255

REF: EN60947-3-256

REF: EN60947-3-257

REF: EN60947-3-258

REF: EN60947-3-259

REF: EN60947-3-260

REF: EN60947-3-261

REF: EN60947-3-262

REF: EN60947-3-263

REF: EN60947-3-264

REF: EN60947-3-265

REF: EN60947-3-266

REF: EN60947-3-267

REF: EN60947-3-268

REF: EN60947-3-269

REF: EN60947-3-270

REF: EN60947-3-271

REF: EN60947-3-272

REF: EN60947-3-273

REF: EN60947-3-274

REF: EN60947-3-275

REF: EN60947-3-276

REF: EN60947-3-277

REF: EN60947-3-278

REF: EN60947-3-279

REF: EN60947-3-280

REF: EN60947-3-281

REF: EN60947-3-282

REF: EN60947-3-283

REF: EN60947-3-284

REF: EN60947-3-285

REF: EN60947-3-286

REF: EN60947-3-287

REF: EN60947-3-288

REF: EN60947-3-289

REF: EN60947-3-290

REF: EN60947-3-291

REF: EN60947-3-292

REF: EN60947-3-293

REF: EN60947-3-294

REF: EN60947-3-295

REF: EN60947-3-296

REF: EN60947-3-297

REF: EN60947-3-298

REF: EN60947-3-299

REF: EN60947-3-300

REF: EN60947-3-301

REF: EN60947-3-302

REF: EN60947-3-303

REF: EN60947-3-304

REF: EN60947-3-305

REF: EN60947-3-306

REF: EN60947-3-307

REF: EN60947-3-308

REF: EN60947-3-309

REF: EN60947-3-310

REF: EN60947-3-311

REF: EN60947-3-312

REF: EN60947-3-313

REF: EN60947-3-314

REF: EN60947-3-315

REF: EN60947-3-316

REF: EN60947-3-317

REF: EN60947-3-318

REF: EN60947-3-319

REF: EN60947-3-320

REF: EN60947-3-321

REF: EN60947-3-322

REF: EN60947-3-323

REF: EN60947-3-324

REF: EN60947-3-325

REF: EN60947-3-326

REF: EN60947-3-327

REF: EN60947-3-328

REF: EN60947-3-329

REF: EN60947-3-330

REF: EN60947-3-331

REF: EN60947-3-332

REF: EN60947-3-333

REF: EN60947-3-334

REF: EN60947-3-335

REF: EN60947-3-336

REF: EN60947-3-337

REF: EN60947-3-338

REF: EN60947-3-339

REF: EN60947-3-340

REF: EN60947-3-341

REF: EN60947-3-342

REF: EN60947-3-343

REF: EN60947-3-344

REF: EN60947-3-345

REF: EN60947-3-346

REF: EN60947-3-347

REF: EN60947-3-348

REF: EN60947-3-349

REF: EN60947-3-350

REF: EN60947-3-351

REF: EN60947-3-352

REF: EN60947-3-353

REF: EN60947-3-354

REF: EN60947-3-355

REF: EN60947-3-356

REF: EN60947-3-357

REF: EN60947-3-358

REF: EN60947-3-359

REF: EN60947-3-360

REF: EN60947-3-361

REF: EN60947-3-362

REF: EN60947-3-363

REF: EN60947-3-364

REF: EN60947-3-365

REF: EN60947-3-366

REF: EN60947-3-367

REF: EN60947-3-368

REF: EN60947-3-369

REF: EN60947-3-370

REF: EN60947-3-371

REF: EN60947-3-372

REF: EN60947-3-373

REF: EN60947-3-374

REF: EN60947-3-375

REF: EN60947-3-376

REF: EN60947-3-377

REF: EN60947-3-378

REF: EN60947-3-379

REF: EN60947-3-380

REF: EN60947-3-381

REF: EN60947-3-382

REF: EN60947-3-383

REF: EN60947-3-384

REF: EN60947-3-385

REF: EN60947-3-386

REF: EN60947-3-387

REF: EN60947-3-388

REF: EN60947-3-389

REF: EN60947-3-390

REF: EN60947-3-391

REF: EN60947-3-392

REF: EN60947-3-393

REF: EN60947-3-394

REF: EN60947-3-395

REF: EN60947-3-396

REF: EN60947-3-397

REF: EN60947-3-398

REF: EN60947-3-399

REF: EN60947-3-400

REF: EN60947-3-401

REF: EN60947-3-402

REF: EN60947-3-403

REF: EN60947-3-404

REF: EN60947-3-405

REF: EN60947-3-406

REF: EN60947-3-407

REF: EN60947-3-408

REF: EN60947-3-409

REF: EN60947-3-410

REF: EN60947-3-411

REF: EN60947-3-412

REF: EN60947-3-413

REF: EN60947-3-414

REF: EN60947-3-415

REF: EN60947-3-416

REF: EN60947-3-417

REF: EN60947-3-418

REF: EN60947-3-419

REF: EN60947-3-420

REF: EN60947-3-421

REF: EN60947-3-422

REF: EN60947-3-423

REF: EN60947-3-424

REF: EN60947-3-425

REF: EN60947-3-426

REF: EN60947-3-427

REF: EN60947-3-428

REF: EN60947-3-429

REF: EN60947-3-430

REF: EN60947-3-431

REF: EN60947-3-432

REF: EN60947-3-433

REF: EN60947-3-434

REF: EN60947-3-435

REF: EN60947-3-436

REF: EN60947-3-437

REF: EN60947-3-438

REF: EN60947-3-439

REF: EN60947-3-440

REF: EN60947-3-441

REF: EN60947-3-442

REF: EN60947-3-443

REF: EN60947-3-444

REF: EN60947-3-445

REF: EN60947-3-446

REF: EN60947-3-447

REF: EN60947-3-448

REF: EN60947-3-449

REF: EN60947-3-450

REF: EN60947-3-451

REF: EN60947-3-452

REF: EN60947-3-453

REF: EN60947-3-454

REF: EN60947-3-455

REF: EN60947-3-456

REF: EN60947-3-457

REF: EN60947-3-458

REF: EN60947-3-459

REF: EN60947-3-460

REF: EN60947-3-461

REF: EN60947-3-462

REF: EN60947-3-463

REF: EN60947-3-464

REF: EN60947-3-465

REF: EN60947-3-466

REF: EN60947-3-467

REF: EN60947-3-468

REF: EN60947-3-469

REF: EN60947-3-470

REF: EN60947-3-471

REF: EN60947-3-472

REF: EN60947-3-473

REF: EN60947-3-474

REF: EN60947-3-475

REF: EN60947-3-476

REF: EN60947-3-477

REF: EN60947-3-478

REF: EN60947-3-479

REF: EN60947-3-480

REF: EN60947-3-481

REF: EN60947-3-482

REF: EN60947-3-483

REF: EN60947-3-484

REF: EN60947-3-485

REF: EN60947-3-486

REF: EN60947-3-487

REF: EN60947-3-488

REF: EN60947-3-489

REF: EN60947-3-490

REF: EN60947-3-491

REF: EN60947-3-492

REF: EN60947-3-493

REF: EN60947-3-494

REF: EN60947-3-495

REF: EN60947-3-496

REF: EN60947-3-497

REF: EN60947-3-498

REF: EN60947-3-499

REF: EN60947-3-500

REF: EN60947-3-501

REF: EN60947-3-502

REF: EN60947-3-503

REF: EN60947-3-504

REF: EN60947-3-505

REF: EN60947-3-506

REF: EN60947-3-507

REF: EN60947-3-508

REF: EN60947-3-509

REF: EN60947-3-510

REF: EN60947-3-511

REF: EN60947-3-512

REF: EN60947-3-513

REF: EN60947-3-514

REF: EN60947-3-515

REF: EN60947-3-516

REF: EN60947-3-517

REF: EN60947-3-518

REF: EN60947-3-519

REF: EN60947-3-520

REF: EN60947-3-521

REF: EN60947-3-522

REF: EN60947-3-523

REF: EN60947-3-524

REF: EN60947-3-525

REF: EN60947-3-526

REF: EN60947-3-527

REF: EN60947-3-528

REF: EN60947-3-529

REF: EN60947-3-530

REF: EN60947-3-531

REF: EN60947-3-532

REF: EN60947-3-533

REF: EN60947-3-534

REF: EN60947-3-535

REF: EN60947-3-536

REF: EN6094