

Dial Test Indicator, Pocket Type

Item number: 513-503-10H

Images

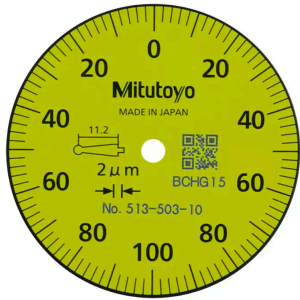

Description

This is a small type Dial Test Indicator (Lever Type) which offers you the following benefits:

- Reversible measuring direction (clutch type)
- Jeweled bearings assure higher sensitivity and accuracy.

Features

Digital/Analog:	Analog
Inch-Metric:	Metric
Delivered:	In a box with stem $\varnothing 6$ mm, stylus $\varnothing 2$ mm
Range:	0.2 mm
Dial reading:	0-100-0
Graduation:	0.002 mm
H MPE (Hysteresis):	2 mm
MPE any 10 scale divisions:	2 μ m
MPE any 1/2 revolution:	3 μ m
MPE measuring range:	3 μ m
R MPE (Repeatability):	1 μ m
Measuring force:	$\leq 0,4$ N
Carbide stylus tip $\varnothing 2$ mm No.:	103010
Contact point:	Thread M 1.7 x 0.35
Remarks:	Basic set

Dimensions

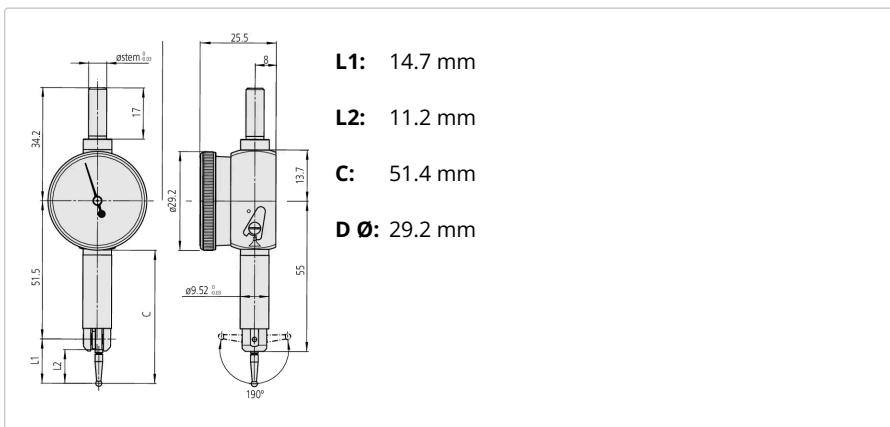

Accessories

Optional accessories:



Limit Hands (Green) 2 pcs.

Dial Indicator Series 1, Test Indicator

Art No. 21AAB363

Price on application

Standard accessories:



Stem for Serie 513

D= 6mm
Art No. 102389
Suggested retail price: 11.00 €*
A vertical cylindrical metal stem. The bottom part has a threaded section. Above it is a wider diameter section with a small hole on the side. The top part is a smooth cylinder.



Stylus for Serie 513

D= 2mm, 11,2mm Length, Carbide
Art No. 103010
Suggested retail price: 21.00 €*
A small, tapered metal stylus. It has a spherical tip, a narrow body, and a wider base with a threaded section.



Spanner R=7,3/4,5mm

Micrometer
Art No. 301336
Suggested retail price: 7.00 €*
A small, curved metal spanner tool with a central notch and two curved ends.