

## Dial Test Indicator, Pocket Type

Item number: 513-501-10E

**Images**

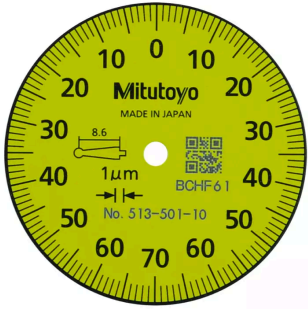

## Description

This is a small type Dial Test Indicator (Lever Type) which offers you the following benefits:

- Reversible measuring direction (clutch type)
- Jeweled bearings assure higher sensitivity and accuracy.

## Features

<b>Digital/Analog:</b>	Analog
<b>Inch-Metric:</b>	Metric
<b>Delivered:</b>	In a box with stem $\varnothing 8$ mm, stylus $\varnothing 2$ mm
<b>Range:</b>	0.14 mm
<b>Dial reading:</b>	0-70-0
<b>Graduation:</b>	0.001 mm
<b>H MPE (Hysteresis):</b>	2 mm
<b>MPE any 10 scale divisions:</b>	2 $\mu\text{m}$
<b>MPE any 1/2 revolution:</b>	3 $\mu\text{m}$
<b>MPE measuring range:</b>	3 $\mu\text{m}$
<b>R MPE (Repeatability):</b>	1 $\mu\text{m}$
<b>Measuring force:</b>	$\leq 0.5$ N
<b>Carbide stylus tip <math>\varnothing 2</math> mm No.:</b>	136104
<b>Contact point:</b>	Thread M 1.7 x 0.35
<b>Remarks:</b>	Basic set

## Dimensions

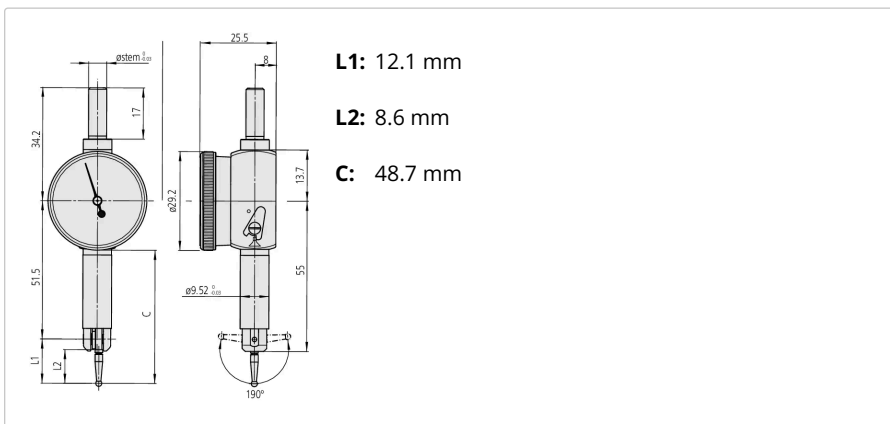

## Accessories

Optional accessories:



### Limit Hands (Green) 2 pcs.

Dial Indicator Series 1, Test Indicator

Art No. 21AAB363

Price on application

Standard accessories:



### Stem for Serie 513

D= 8mm  
Art No. 102822  
Suggested retail price: 12.00 €\*



### Stylus for Small Type Serie 513

D=2mm, 8,6mm Length, Carbide  
Art No. 136104  
Suggested retail price: 18.00 €\*



### Spanner R=7,3/4,5mm

Micrometer  
Art No. 301336  
Suggested retail price: 7.00 €\*