

## Dial Gauge, ANSI/AGD Type

Item number: 2991A-10

### Images



### Description

This is a back plunger type dial indicator with bezel  $\varnothing$  57 mm.

### Features

<b>Digital/Analog:</b>	Analog
<b>Inch-Metric:</b>	Inch
<b>Type:</b>	ANSI/AGD Standard
<b>Range:</b>	0,008 "
<b>Range per rev.:</b>	0.008"
<b>Dial reading:</b>	4-0-4
<b>Delivered:</b>	With certificate of inspection
<b>Graduation:</b>	0.0001"
<b>H MPE (Hysteresis):</b>	0,0001"
<b>R MPE (Repeatability):</b>	$\pm 0,00005$ "
<b>MPE first one revolution:</b>	$\pm 0,0002$ "
<b>Measuring force:</b>	0,4-1,5 N
<b>Stem:</b>	9.52 mm / 0.375"
<b>Contact point:</b>	Carbide tipped, thread: 4-48UNF
<b>Mass:</b>	205 g

### Dimensions

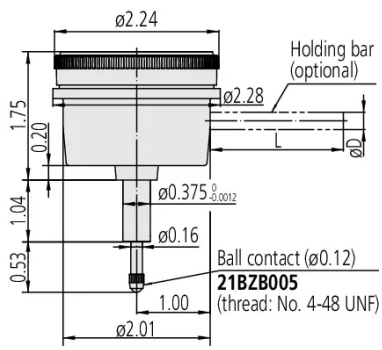

## Accessories

### Optional accessories:



### Holding Bar for Back Plunger Indicator

$\varnothing 8$  mm, 81 mm Length  
 Art No. 136568  
 Suggested retail price: 5.30 €\*



### Limit Hands (green) 2pcs

Dial Indicator Series 2/3/4  
 Art No. 21AZB195  
 Price on application



### Holding Bar for Back Plunger Indicator

$\varnothing 6$  mm, 42 mm Length  
 Art No. 21AAA166  
 Suggested retail price: 5.80 €\*



### Holding Bar for Back Plunger Indicator

$\varnothing 6$  mm, 81 mm Length  
 Art No. 136567  
 Suggested retail price: 7.90 €\*

### **Holding Bar for Back Plunger Indicator**



Ø6,35mm, 81mm Length  
Art No. 124625  
Suggested retail price: 7.90 €\*  

---

### **Holding Bar for Back Plunger Indicator**



Ø6,35mm, 42mm Length  
Art No. 21AAA167  
Suggested retail price: 5.80 €\*  

---

### **Holding Bar for Back Plunger Indicator**



Ø 8 mm, 42 mm Length  
Art No. 21AAA168  
Suggested retail price: 6.30 €\*  

---

### **Spare parts**

Consumable spares:

---

### **Contact Element Ball Point, 4-48UNF**



1/4" Length, Carbide, Inch  
Art No. 21BZB005  
Suggested retail price: 13.30 €\*  

---