

Dial Gauge, Flat Back, ISO Type

Item number: 1929AB

Images

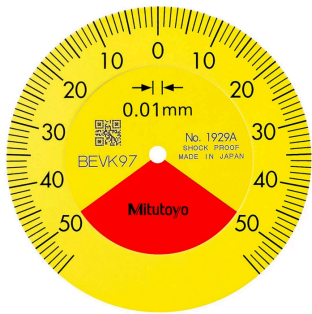
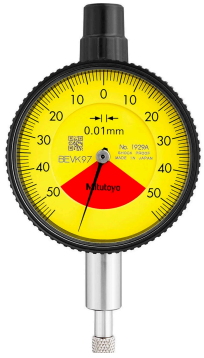

Description

This is a compact, metric dial indicator. It offers you the following benefits:

- It eliminates the possibility of reading errors due to miscounting multiple revolutions.

Features

Digital/Analog:	Analog
Inch-Metric:	Metric
Type:	EN ISO Standard
Range:	1 mm
Plunger Stroke:	3.5 mm
Range per rev.:	1,4 mm
Dial reading:	50-0-50
Delivered:	With certificate of inspection
Graduation:	0.01 mm

MPE any 1/10 revolution:	5 µm
MPE measuring range:	9 µm
H MPE (Hysteresis):	3 µm
R MPE (Repeatability):	3 µm
Measuring force:	0,4-1,4 N
Stem:	8 mm
Contact point:	Carbide tipped, thread: M 2.5 x 0.45 mm
Balanced dial:	Yes
One revolution:	Yes
Shockproof:	Yes
Mass:	70 g

Dimensions

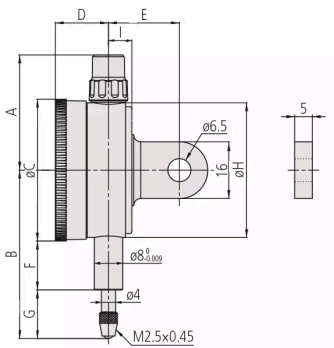

- A:** 32.5 mm
- B:** 47.5 mm
- C:** 40 mm
- D:** 15 mm
- E:** 20 mm
- F:** 13.8 mm
- G:** 13.7 mm
- H:** 38 mm
- I:** 6.6 mm

Accessories

Optional accessories:



Limit Hands (Green) 2 pcs.

Dial Indicator Series 1, Test Indicator
Art No. 21AAB363

Price on application



Bezel Clamp for Dial Gauge

Series 1

Art No. 21RZA149

Price on application

Spindle Lifting Lever

for S-Type and A-Type Serie 1

Art No. 902100

Price on application



Spindle Lifting Cable

for Indicator, L=500mm

Art No. 21JZA295

Price on application



Spindle Lifting Cable with Auto Stop

for Indicator, L=300mm

Art No. 21JZA301

Price on application



Spare parts

Consumable spares:



**Contact Element Ball Point,
M2,5x0,45**

7,3mm Length, Carbide, Metric

Art No. 901312

Suggested retail price: 5.00 €*
