

Dial Gauge, Flat Back, ISO Type

Item number: 1929AB-62

Images



Description

This is a compact, metric dial indicator. It offers you the following benefits:

- It eliminates the possibility of reading errors due to miscounting multiple revolutions.

Features

Digital/Analog:	Analog
Inch-Metric:	Metric
Type:	EN ISO Standard
Range:	1 mm
Plunger Stroke:	3.5 mm
Range per rev.:	1,4 mm
Dial reading:	50-0-50
Delivered:	With certificate of inspection
Graduation:	0.01 mm
MPE any 1/10 revolution:	5 μ m
MPE measuring range:	9 μ m

H MPE (Hysteresis):	3 μm
R MPE (Repeatability):	3 μm
Measuring force:	0,4-1,4 N
Stem:	8 mm
Contact point:	Carbide tipped, thread: M 2.5 x 0.45 mm
Balanced dial:	Yes
One revolution:	Yes
Shockproof:	Yes
Mass:	70 g

Dimensions

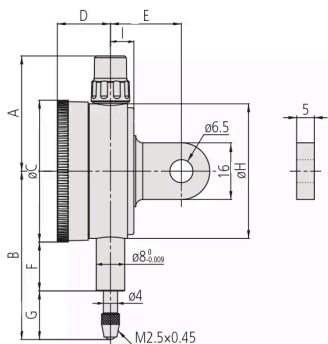

A:	32.5 mm
B:	47.5 mm
C:	40 mm
D:	15 mm
E:	20 mm
F:	13.8 mm
G:	13.7 mm
H:	38 mm
I:	6.6 mm

Accessories

Optional accessories:



Limit Hands (Green) 2 pcs.

Dial Indicator Series 1, Test Indicator
Art No. 21AAB363

Price on application



Bezel Clamp for Dial Gauge

Series 1
Art No. 21RZA149

Price on application

Spindle Lifting Lever

for S-Type and A-Type Serie 1

Art No. 902100

[Price on application](#)



Spindle Lifting Cable

for Indicator, L=500mm

Art No. 21JZA295

[Price on application](#)



Spindle Lifting Cable with Auto Stop

for Indicator, L=300mm

Art No. 21JZA301

[Price on application](#)



Spare parts

Consumable spares:



Contact Element Ball Point, M2,5x0,45

7,3mm Length, Carbide, Metric

Art No. 901312

Suggested retail price: 5.00 €*