

Dial Gauge, Lug Back, ISO Type

Item number: 1044A

Images



Description

Compact Type 5 mm Range Small Diameter - Metric

This is a compact, dial indicator with a bezel \varnothing 40 mm. It offers you the following benefits:

- It is ideal for use in applications where space is limited.

Features

Digital/Analog:	Analog
Inch-Metric:	Metric
Delivered:	With certificate of inspection
Range:	5 mm
Range per rev.:	1 mm
Dial reading:	$\pm 0-100$
Graduation:	0.01 mm
MPE any 1/10 revolution:	5 μ m
MPE any 1/2 revolution:	9 μ m
MPE any 1 revolution:	10 μ m
MPE measuring range:	12 μ m
H MPE (Hysteresis):	3 μ m

R MPE (Repeatability):	3 µm
Measuring force:	0,4-1,4 N
Mass:	90 g
Stem:	8 mm
Contact point:	Carbide tipped, thread: M 2.5 x 0.45 mm
Continuous dial:	Yes
Type:	EN ISO Standard

Dimensions

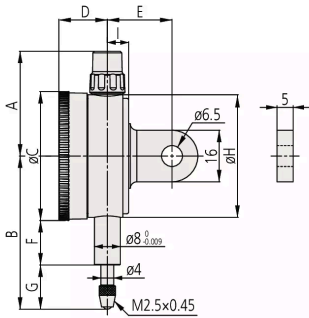

A:	32.5 mm
B:	47.5 mm
C:	40 mm
D:	15 mm
E:	20 mm
F:	13.8 mm
G:	13.7 mm
H:	38 mm
I:	6.6 mm

Accessories

Optional accessories:



Limit Hands (Green) 2 pcs.

Dial Indicator Series 1, Test Indicator
Art No. 21AAB363
[Price on application](#)



Bezel Clamp for Dial Gauge

Series 1
Art No. 21RZA149
[Price on application](#)

Spindle Lifting Lever

for S-Type and A-Type Serie 1

Art No. 902100

[Price on application](#)



Spindle Lifting Cable

for Indicator, L=500mm

Art No. 21JZA295

[Price on application](#)



Spindle Lifting Cable with Auto Stop

for Indicator, L=300mm

Art No. 21JZA301

[Price on application](#)



Spare parts

Consumable spares:



Contact Element Ball Point, M2,5x0,45

7,3mm Length, Carbide, Metric

Art No. 901312

Suggested retail price: 14.00 €*