

## Dial Gauge, Lug Back, ISO Type

Item number: 1044A-15

### Images



### Description

#### Compact Type 5 mm Range Small Diameter - Metric

This is a compact, dial indicator with a bezel  $\varnothing$  40 mm. It offers you the following benefits:

- It is ideal for use in applications where space is limited.

### Features

<b>Digital/Analog:</b>	Analog
<b>Inch-Metric:</b>	Metric
<b>Range:</b>	5 mm
<b>Range per rev.:</b>	1 mm
<b>Dial reading:</b>	$\pm 0-100$
<b>Delivered:</b>	With certificate of inspection
<b>Graduation:</b>	0.01 mm
<b>MPE any 1/10 revolution:</b>	5 $\mu$ m
<b>MPE any 1/2 revolution:</b>	9 $\mu$ m
<b>MPE any 1 revolution:</b>	10 $\mu$ m
<b>MPE measuring range:</b>	12 $\mu$ m
<b>H MPE (Hysteresis):</b>	3 $\mu$ m

<b>R MPE (Repeatability):</b>	3 µm
<b>Measuring force:</b>	0,1-0,4 N
<b>Stem:</b>	8 mm
<b>Contact point:</b>	Carbide tipped, thread: M 2.5 x 0.45 mm
<b>Continuous dial:</b>	Yes
<b>Type:</b>	EN ISO Standard
<b>Mass:</b>	90 g

## Dimensions

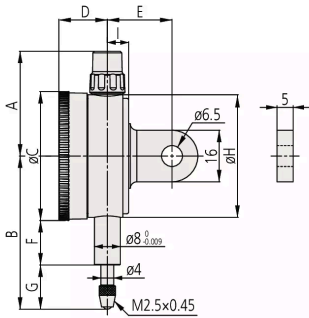

<b>A:</b>	32.5 mm
<b>B:</b>	47.5 mm
<b>C:</b>	40 mm
<b>D:</b>	15 mm
<b>E:</b>	20 mm
<b>F:</b>	13.8 mm
<b>G:</b>	13.7 mm
<b>H:</b>	38 mm
<b>I:</b>	6.6 mm

## Accessories

### Optional accessories:



### Limit Hands (Green) 2 pcs.

Dial Indicator Series 1, Test Indicator  
Art No. 21AAB363

[Price on application](#)



### Bezel Clamp for Dial Gauge

Series 1  
Art No. 21RZA149

[Price on application](#)

## Spindle Lifting Lever

for S-Type and A-Type Serie 1

Art No. 902100

[Price on application](#)



## Spindle Lifting Cable

for Indicator, L=500mm

Art No. 21JZA295

[Price on application](#)



## Spindle Lifting Cable with Auto Stop

for Indicator, L=300mm

Art No. 21JZA301

[Price on application](#)



## Spare parts

Consumable spares:



## Contact Element Ball Point, M2,5x0,45

7,3mm Length, Carbide, Metric

Art No. 901312

Suggested retail price: 5.00 €\*