

PRODUCT INFORMATION PACKET

Model No: 256TTDX7264
Catalog No: Y458
10,1800/1200,DP,256T,3/60/460
Other Purpose



Regal and Marathon are trademarks of Regal Beloit Corporation or one of its affiliated companies.
©2018 Regal Beloit Corporation, All Rights Reserved. MC017097E





Nameplate Specifications

Output HP	10,4.44 Hp	Output KW	7.5 kW
Frequency	60 Hz	Voltage	460 V
Current	12,6.5 A	Speed	1760,1175 rpm
Service Factor	1.15	Phase	3
Efficiency	87.5 %	Duty	CONTINUOUS
Insulation Class	B	Design Code	2VT
KVA Code	H	Frame	256T
Enclosure	DP	Overload Protector	NOT
Ambient Temperature	40 °C	Drive End Bearing Size	6309
Opp Drive End Bearing Size	6208	UL	Recognized
CSA	Y	CE	Y
IP Code	12		

Technical Specifications

Electrical Type	SQ CAGE IND RUN	Starting Method	ACROSS THE LINE
Poles	4//6	Rotation	REV
Mounting	RIGID	Motor Orientation	HORIZONTAL
Drive End Bearing	BALL	Opp Drive End Bearing	BALL
Frame Material	ROLLED STEEL	Shaft Type	T
Overall Length	22.32 in	Frame Length	15.45 in
Shaft Diameter	1.63 in	Shaft Extension	4.19 in
Assembly/Box Mounting	F1/F2 CAPABLE		
Outline Drawing	A-SS86503-1545	Connection Diagram	A-EE7317

This is an uncontrolled document once printed or downloaded and is subject to change without notice. Date Created: 04/06/2018

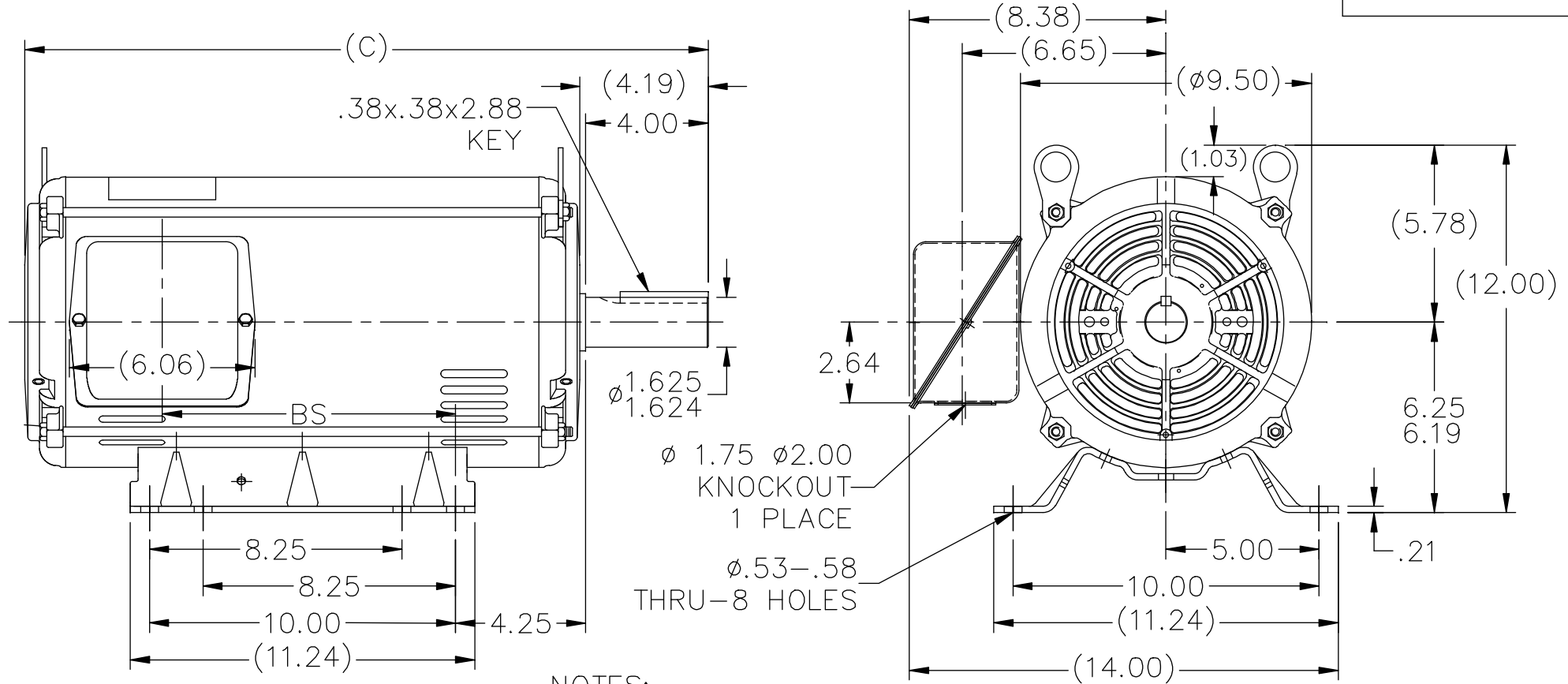

NOTES:

1. NAMEPLATE TO BE READ FROM C'BOX SIDE OF MOTOR.
2. BOX CAN BE MOUNTED IN 90° STEPS.
3. BOX CAN BE MOUNTED ON OPPOSITE SIDE BY REMOVING BRACKETS AND TURNING FRAME 180°. (EXCEPT AS NOTED.)
4. F2 MOUNT -USES 2ND HOLE ON 1370 FRAME.

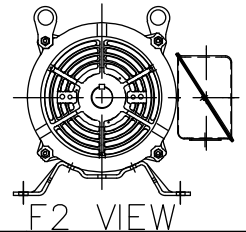

DASH	FR.	C	BS	MOUNTING
1370	254T	20.57	7.68	F1 OR F2
1545	254T/256T	22.32	9.43	F1 OR F2

NO.	REVISION	BY & DATE	CHK	ANG	±7'30"	FINISH	PREV	
8	ADDED F2 VIEW	UD 11/13/13	GR	TOLERANCES UNLESS SPECIFIED			DRAWN SMC 04-22-1993	
7	UPDATED DRAWING	TJW 04/27/2007		DEC.	INCHES		CHK MOL 04-23-1993	
6	REDRAWN IN AUTOCAD	TAT 05-19-2005	ML	.X	±.1	APPD DRN 09-13-1993	SCALE 1=5	
5	UPDATED CONDUIT BOX CN 28427	TJB 01-31-2000		.XX	±.03	TITLE OUTLINE	REF	
4	ADDED NOTE #4 FOR F2 MOUNT CN 24000-581	MH 06-10-1997		.XXX	±.005	250 FR. - BB - DR.PR.	FMF	
3	DASH 1545 WAS FOR 256T FR. ONLY CN 18683	KL 09-12-1994		.XXXX	±.0005	MAT'L.	PREV	
THIS DRAWING IN DESIGN AND DETAIL IS OUR PROPERTY AND MUST NOT BE USED EXCEPT IN CONNECTION WITH OUR WORK ALL RIGHTS OF DESIGN AND INVENTION ARE RESERVED THIS IS AN ELECTRONICALLY GENERATED DOCUMENT - DO NOT SCALE THIS PRINT			RFP	CAD FILE ss86503		SIZE A	DRAWING NO. SS86503	PAGE OF 8
			DIST LB					REV. 8

LOW SPEED

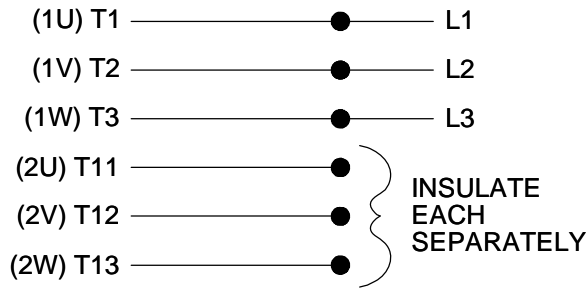

HIGHSPEED

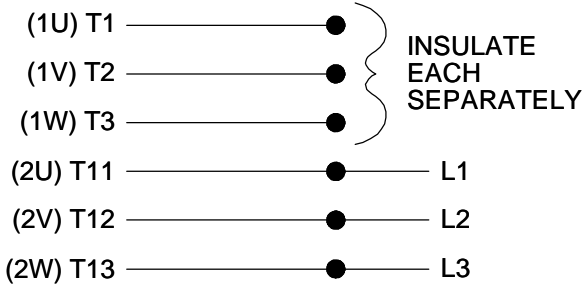

**THREE PHASE, SINGLE VOLT, 6 LEAD
2 SPEED REVERSIBLE MOTOR**

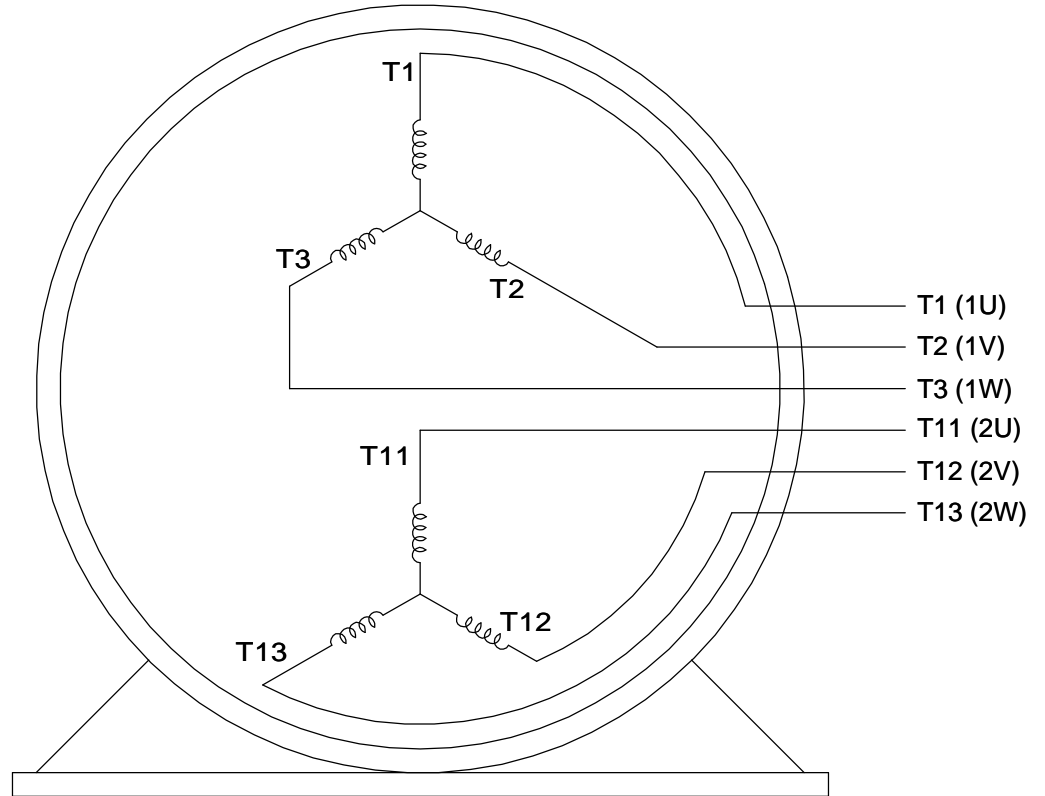



VIEW OF TERMINAL END

TO REVERSE ROTATION ON
EITHER SPEED: INTERCHANGE
ANY 2 LEADS ON THE
WINDING IN USE.

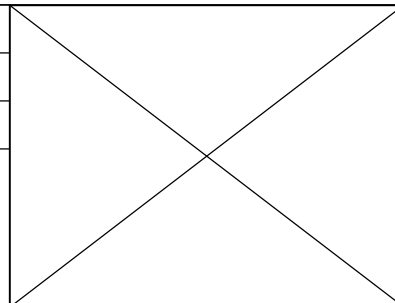
DRAWING REVISION C	REVISION BY JJB	DATE 10-25-2017
ECO ECO-0132917	APPROVED BY TLB	DATE 10-30-2017
ECO DESCRIPTION REVISED PER ECO & UPDATED TO STANDARDS		
<small>COPYRIGHT REGAL BELOIT AMERICA, INC. ALL RIGHTS RESERVED. PROPRIETARY AND CONFIDENTIAL INFORMATION - THIS DOCUMENT IS THE PROPERTY OF REGAL BELOIT AMERICA, INC. ("OWNER") AND CONTAINS OWNER'S PROPRIETARY INFORMATION. ANY PERSON, CORPORATION OR OTHER FIRM RECEIVING IT IS DEEMED, BY RECEIVING IT, TO AGREE THAT IT, AND/OR ANY PART OF IT, SHALL NOT BE DISCLOSED TO ANY PERSON, CORPORATION OR OTHER ENTITY, DUPLICATED, AND/OR USED, EXCEPT AS EXPRESSLY APPROVED IN WRITING IN ADVANCE BY OWNER. THIS DOCUMENT SHALL BE RETURNED TO OWNER UPON REQUEST. IT MAY BE SUBJECT TO CERTAIN RESTRICTIONS UNDER APPLICABLE EXPORT CONTROL LAWS AND REGULATIONS.</small>		



DRAWN BY LZ	 Regal Beloit America, Inc.		
DATE 01-05-1994			
APPROVED BY GK	DESCRIPTION CONN DIAGRAM-INTERNAL		
DATE 01-17-1994	3 PHASE - SINGLE - 2 SPEED REVERSIBLE		
REFERENCE	MATERIAL	PROCESS/FINISH	
THIRD ANGLE PROJECTION 	SIZE A	DRAWING NUMBER EE7317	SHEET 1 OF 1

