

PRODUCT INFORMATION PACKET

marathon[®]
Motors

Model No: 364TSTFS14009
Catalog No: Y1622
60,3600,TEFC,364TS,3/60/230/460
Fire Pump



Regal and Marathon are trademarks of Regal Beloit Corporation or one of its affiliated companies.
©2018 Regal Beloit Corporation, All Rights Reserved. MC017097E

REGAL[®]



Nameplate Specifications

Output HP	60 Hp	Output KW	45.0 kW
Frequency	60 Hz	Voltage	230/460 V
Current	138.0/69.0 A	Speed	3555 rpm
Service Factor	1.15	Phase	3
Efficiency	93 %	Duty	Continuous
Insulation Class	F	Design Code	B
KVA Code	F	Frame	364TS
Enclosure	Totally Enclosed Fan Cooled	Overload Protector	No
Ambient Temperature	40 °C	Drive End Bearing Size	6316
Opp Drive End Bearing Size	6313	UL	No
CSA	Y	CE	Y
IP Code	43		

Technical Specifications

Electrical Type	Squirrel Cage Induction Run	Starting Method	Wye Start Delta Run
Poles	2	Rotation	Reversible
Mounting	Rigid base	Motor Orientation	HORIZONTAL
Drive End Bearing	BALL	Opp Drive End Bearing	BALL
Frame Material	Cast Iron	Shaft Type	TS
Overall Length	29.38 in	Frame Length	13.50 in
Shaft Diameter	1.875 in	Shaft Extension	4.00 in
Assembly/Box Mounting	F1/F2 CAPABLE		
Outline Drawing	B-SS504620-1350	Connection Diagram	A-EE7308AA

This is an uncontrolled document once printed or downloaded and is subject to change without notice. Date Created: 10/30/2018

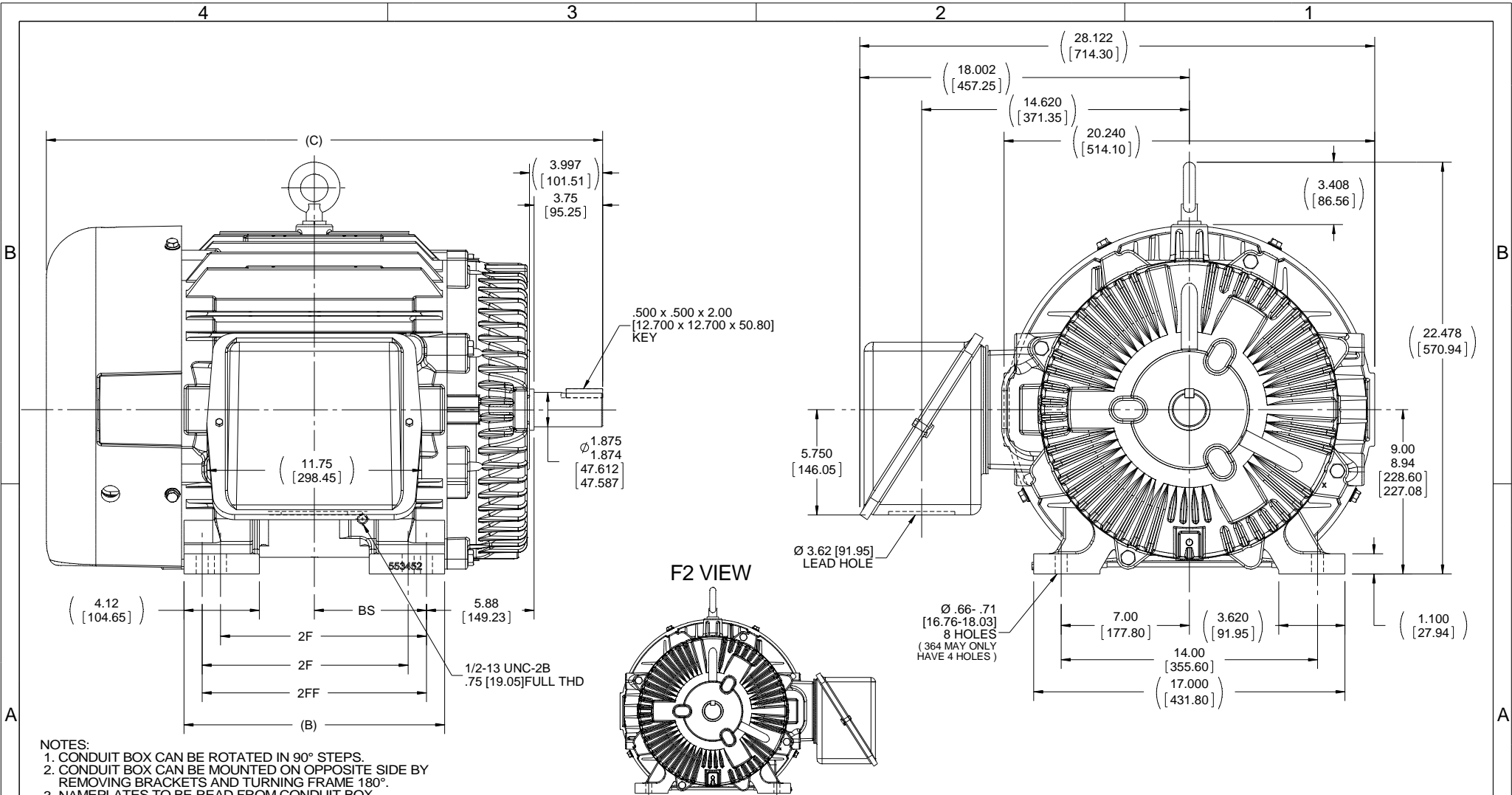

- NOTES:
 1. CONDUIT BOX CAN BE ROTATED IN 90° STEPS.
 2. CONDUIT BOX CAN BE MOUNTED ON OPPOSITE SIDE BY REMOVING BRACKETS AND TURNING FRAME 180°.
 3. NAMEPLATES TO BE READ FROM CONDUIT BOX SIDE OF MOTOR.
 4. DIMENSION IN [] DESIGNATE MILLIMETERS.

DASH	FRAME	B	C	2F	2FF	BS
1350	364TS	13.25 [336.55]	29.38 [746.25]	11.25 [285.75]	---	5.62 [142.75]
1450	364/365TS	14.25 [361.95]	30.38 [771.65]	11.25 [285.75]	12.25 [311.15]	6.12 [155.45]

DRAWING REVISION C
 ECO ECO-0074104
 ECO DESCRIPTION
 UPDATED TO CURRENT STANDARDS
 COPYRIGHT REGAL BELOIT AMERICA, INC. ALL RIGHTS RESERVED.
 PROPRIETARY AND CONFIDENTIAL INFORMATION - THIS DOCUMENT IS THE PROPERTY OF REGAL BELOIT AMERICA, INC. (OWNER) AND CONTAINS OWNER'S PROPRIETARY INFORMATION. ANY PERSON, CORPORATION OR OTHER FIRM RECEIVING IT IS DEEMED, BY RECEIVING IT, TO AGREE THAT IT, AND/OR ANY PART OF IT, SHALL NOT BE DISCLOSED TO ANY PERSON, CORPORATION OR OTHER ENTITY, DUPLICATED, AND/OR USED, EXCEPT AS EXPRESSLY APPROVED IN WRITING IN ADVANCE BY OWNER. THIS DOCUMENT SHALL BE RETURNED TO OWNER UPON REQUEST. IT MAY BE SUBJECT TO CERTAIN RESTRICTIONS UNDER APPLICABLE EXPORT CONTROL LAWS AND REGULATIONS.

REVISION BY JJB
 APPROVED BY TDB
 DATE 03-24-2015
 DATE 03-25-2015
 TOLERANCES UNLESS OTHERWISE SPECIFIED:
 DEC INCH mm ANGLE
 .X ±0.1 [+2.5] ±0.5°
 .XX ±0.01 [+0.25]
 .XXX ±0.005 [+0.127]
 .XXXX ±0.0005 [+0.0127]
 REMOVE BURRS & BREAK SHARP EDGES: .003/.015 [.076/.381] X 45°
 CORNER FILLETS: R.02 [.51]
 MACHINED SURFACES: 125 INCH/mm 3.2
 mm SHOWN IN [BRACKETS]

DRAWN BY TLB
 DATE 04-29-1988
 APPROVED BY ML
 DATE 04-29-1988
 REFERENCE

REGAL™ Regal Beloit America, Inc.

DESCRIPTION
OUTLINE
 360TS FR- TEFC- (STD.)

MATERIAL PROCESS/FINISH

THIRD ANGLE PROJECTION

SIZE B DRAWING NUMBER **SS504620** SHEET 1 OF 1



LOW VOLTAGE



HIGH VOLTAGE



VIEW OF TERMINAL END

DRAWING REVISION K	REVISION BY AJW	DATE 07-17-2015
ECO ECO-0081632	APPROVED BY T. VUE	DATE 07-17-2015
ECO DESCRIPTION REV'D IEC MARKINGS PER IEC 60034-8		
<small> COPYRIGHT REGAL BELOIT AMERICA, INC. ALL RIGHTS RESERVED. PROPRIETARY AND CONFIDENTIAL INFORMATION - THIS DOCUMENT IS THE PROPERTY OF REGAL BELOIT AMERICA, INC. ("OWNER") AND CONTAINS OWNER'S PROPRIETARY INFORMATION. ANY PERSON, CORPORATION OR OTHER FIRM RECEIVING IT IS DEEMED, BY RECEIVING IT, TO AGREE THAT IT, AND/OR ANY PART OF IT, SHALL NOT BE DISCLOSED TO ANY PERSON, CORPORATION OR OTHER ENTITY, DUPLICATED, AND/OR USED, EXCEPT AS EXPRESSLY APPROVED IN WRITING IN ADVANCE BY OWNER. THIS DOCUMENT SHALL BE RETURNED TO OWNER UPON REQUEST. IT MAY BE SUBJECT TO CERTAIN RESTRICTIONS UNDER APPLICABLE EXPORT CONTROL LAWS AND REGULATIONS. </small>		

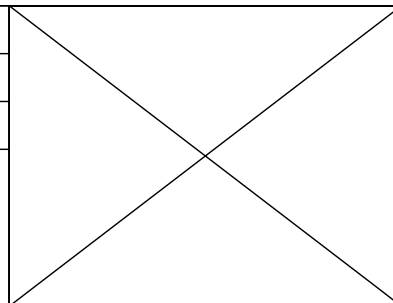

DRAWN BY LZ	Regal Beloit America, Inc.	
DATE 01-12-1994		
APPROVED BY GK	DESCRIPTION CONN DIAGRAM-EXTERNAL 3Ø-2/1 DELTA-12 LEADS	
DATE 01-14-1994		
REFERENCE	MATERIAL	PROCESS/FINISH
THIRD ANGLE PROJECTION	SIZE A	DRAWING NUMBER EE7308AA
		SHEET 1 OF 1

