

PRODUCT INFORMATION PACKET

Model No: 364THFCD9036

Catalog No: W587A

60 HP, Severe Duty Motors, 3 phase, 1800 RPM, 460 V, 364T Frame, TEFC
Other Severe Duty Motors



Nameplate Specifications

Output HP	60 Hp	Output KW	45.0 kW
Frequency	60 Hz	Voltage	460 V
Current	69.0 A	Speed	1782 rpm
Service Factor	1.15	Phase	3
Efficiency	95 %	Power Factor	85.5
Duty	Continuous	Insulation Class	H
Design Code	B	KVA Code	G
Frame	364T	Enclosure	Totally Enclosed Fan Cooled
Thermal Protection	No	Ambient Temperature	40 °C
Drive End Bearing Size	6313	Opp Drive End Bearing Size	6213
UL	Listed	CSA	Y
CE	Y	IP Code	56
Hazardous Location	DIVISION 2 T2B		

Technical Specifications

Electrical Type	Squirrel Cage Inverter Rated	Starting Method	Line Or Inverter
Poles	4	Rotation	Selective Clockwise
Resistance Main	.103 Ohms	Mounting	Rigid Base
Motor Orientation	Horizontal	Drive End Bearing	Ball
Opp Drive End Bearing	Ball	Frame Material	Cast Iron
Shaft Type	T	Shaft Diameter	2.375 in
Assembly/Box Mounting	F1/F2 CAPABLE		
Connection Drawing	EE7300U	Outline Drawing	SS557662-364T

This is an uncontrolled document once printed or downloaded and is subject to change without notice. Date Created:20/08/2020

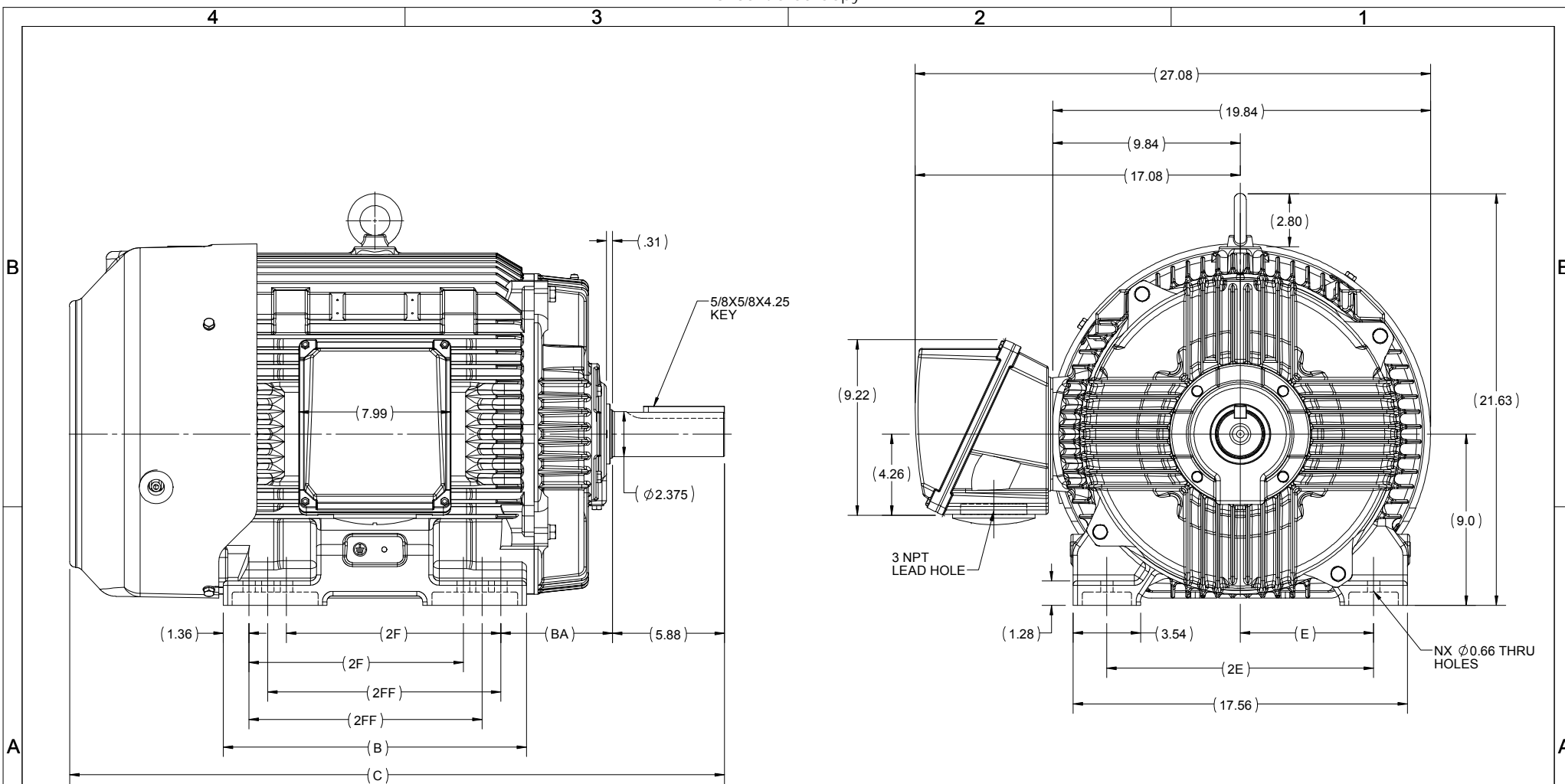

364/365T	15.94	34.40	12.25	11.25	5.88	7.00	14.00	12	F1 OR F2
364T	14.96	33.42	11.25	-				8	F1 OR F2
FRAME	B	C	2FF	2F	BA	E	2E	N	MOUNTING

DRAWING REVISION B	REVISION BY BISWA	DATE 25/01/2018
ECO ECO-0160791	APPROVED BY SBD	DATE 25/01/2018
ECO DESCRIPTION DRAWING UPDATED		
<small>COPYRIGHT REGAL BELOIT AMERICA, INC. ALL RIGHTS RESERVED. PROPRIETARY AND CONFIDENTIAL INFORMATION - THIS DOCUMENT IS THE PROPERTY OF REGAL BELOIT AMERICA, INC. ("OWNER") AND CONTAINS OWNER'S PROPRIETARY INFORMATION. ANY PERSON, CORPORATION OR OTHER FIRM RECEIVING IT IS DEEMED, BY RECEIVING IT, TO AGREE THAT IT, AND/OR ANY PART OF IT, SHALL NOT BE DISCLOSED TO ANY PERSON, CORPORATION OR OTHER ENTITY, DUPLICATED, AND/OR USED, EXCEPT AS EXPRESSLY APPROVED IN WRITING IN ADVANCE BY OWNER. THIS DOCUMENT SHALL BE RETURNED TO OWNER UPON REQUEST. IT MAY BE SUBJECT TO CERTAIN RESTRICTIONS UNDER APPLICABLE EXPORT CONTROL LAWS AND REGULATIONS.</small>		

DRAWN BY BISWA	 Regal Beloit America, Inc.
DATE 01/10/2018	
APPROVED BY SBD	DESCRIPTION OUTLINE 364/365T FR-NEMA-SD & IEEEE841
DATE 01/10/2018	MATERIAL
REFERENCE	PROCESS/FINISH
THIRD ANGLE PROJECTION	SIZE B
	DRAWING NUMBER SS557662
	SHEET 1 OF 1

4 3 2 1

IF MOTOR HAS 9 LEADS



IF MOTOR HAS 6 LEADS



A-9806 DECAL IF CALLED FOR

IF MOTOR HAS 12 LEADS



VIEW OF TERMINAL END

DRAWING REVISION L	REVISION BY AJW	DATE 05-04-2015	TOLERANCES UNLESS OTHERWISE SPECIFIED:	DRAWN BY DRS	Regal Beloit America, Inc.																			
ECO ECO-0077067	APPROVED BY EWH	DATE 05-05-2015	<table style="font-size: small; border-collapse: collapse;"> <tr> <td><u>DEC.</u></td> <td><u>INCH</u></td> <td><u>mm</u></td> <td><u>ANGLE</u></td> </tr> <tr> <td>.X</td> <td>±0.1</td> <td>[±2.5]</td> <td>±7' 30"</td> </tr> <tr> <td>.XX</td> <td>±0.02</td> <td>[±0.51]</td> <td></td> </tr> <tr> <td>.XXX</td> <td>±0.005</td> <td>[±0.127]</td> <td></td> </tr> <tr> <td>.XXXX</td> <td>±0.0005</td> <td>[±0.0127]</td> <td></td> </tr> </table>	<u>DEC.</u>		<u>INCH</u>	<u>mm</u>	<u>ANGLE</u>	.X	±0.1	[±2.5]	±7' 30"	.XX	±0.02	[±0.51]		.XXX	±0.005	[±0.127]		.XXXX	±0.0005	[±0.0127]	
<u>DEC.</u>	<u>INCH</u>	<u>mm</u>	<u>ANGLE</u>																					
.X	±0.1	[±2.5]	±7' 30"																					
.XX	±0.02	[±0.51]																						
.XXX	±0.005	[±0.127]																						
.XXXX	±0.0005	[±0.0127]																						
ECO DESCRIPTION UPDATED TO SOLIDWORKS			REMOVE BURRS & BREAK SHARP EDGES: .003/.015 [.076/.381] X 45° CORNER FILLETS: R.02 [.51] MACHINED SURFACES: 200 $\sqrt{\text{INCH}}$ 5.1 $\sqrt{\text{mm}}$ mm SHOWN IN [BRACKETS]	APPROVED BY GK	DESCRIPTION CONN DIAGRAM-EXTERNAL 3Ø SINDLE VOLTAGE																			
COPYRIGHT REGAL BELOIT AMERICA, INC. ALL RIGHTS RESERVED. PROPRIETARY AND CONFIDENTIAL INFORMATION - THIS DOCUMENT IS THE PROPERTY OF REGAL BELOIT AMERICA, INC. ("OWNER") AND CONTAINS OWNER'S PROPRIETARY INFORMATION. ANY PERSON, CORPORATION OR OTHER FIRM RECEIVING IT IS DEEMED, BY RECEIVING IT, TO AGREE THAT IT, AND/OR ANY PART OF IT, SHALL NOT BE DISCLOSED TO ANY PERSON, CORPORATION OR OTHER ENTITY, DUPLICATED, AND/OR USED, EXCEPT AS EXPRESSLY APPROVED IN WRITING IN ADVANCE BY OWNER. THIS DOCUMENT SHALL BE RETURNED TO OWNER UPON REQUEST. IT MAY BE SUBJECT TO CERTAIN RESTRICTIONS UNDER APPLICABLE EXPORT CONTROL LAWS AND REGULATIONS.				DATE 09-30-1996		MATERIAL	PROCESS/FINISH																	
				REFERENCE	SIZE A	DRAWING NUMBER EE7300U	SHEET 1 OF 1																	



DATA VOLTS: 460

CERTIFICATION DATA SHEET

CONN. DIAGRAM: EE7300U
 OUTLINE: SS557662-364T
 WINDING: HE32254010 NONE 1

REFERENCE MODEL #: 364THFCD9036
 CAT #: W587A

MOUNTING: F1/F2 CAPABLE

TYPICAL MOTOR PERFORMANCE DATA

HP	KW	SYNC RPM	FL RPM	FRAME	ENCLOSURE	TYPE	KVA CODE	DESIGN
60	45	1800	1782	364T	TEFC	TFC	G	B

PH	HZ	VOLTS	AMPS	START TYPE	DUTY	INSL	S.F.	AMB (° C)	ELEV.(Ft)
3	60	460	69	LINE OR INVERTER	CONT	H	1.15	40	3300

F.L. EFF	95.0	3/4 LD EFF	95.4	1/2 LD EFF	95.0	GTD EFF	ELECT. TYPE
F.L. PF	85.5	3/4 LD PF	83.0	1/2 LD PF	75.5	94.5	SQ CAGE INV RATED

F.L. TORQUE	LR AMPS @ 460 V	L.R. TORQUE	B.D. TORQUE	F.L. RISE (° C)
177 LB-FT	435	354 LB-FT 200%	451 LB-FT 255%	55

SOUND PRESSURE @	SOUND	ROTOR WK ²	MAX. LOAD WK ²	SAFE STALL TIME	STARTS/HOUR	APROX.
72 dBA	81 dBA	17.2 LB-FT ²	425 LB-FT ²	25 SEC.	2	398 LB.

*** SUPPLEMENTAL INFORMATION ***

DE BRACKET TYPE	ODE BRACKET TYPE	MOUNT TYPE	MOTOR ORIENTATION	SEVERE DUTY	HAZARDOUS LOCATION	DRIP COVER	SCREENS	PAINT
STANDARD	STANDARD	RIGID	HORIZONTAL	PREMIUM SEVERE DUTY	DIVISION 2 T2B	NO	NONE	BLUE (EPOXY)

BEARINGS		GREASE	SHAFT TYPE	SPECIAL DE	SPECIAL ODE	SHAFT MATERIAL	FRAME MATERIAL
DE	ODE	POLYREX EM	T	NONE	NONE	1045 HOT ROLLED (C-204)	CAST IRON
BALL	BALL						
6313	6213						

THERMOSTATS	PROTECTORS	WDG RTD's	BRG RTD's	THERMISTORS	CONTROL	SPACE HEATERS
NONE	NOT	NONE	NONE	NONE	FALSE	NA

R1 (ohms/ph)	R2 (ohms/ph)	X1 (ohms/ph)	X2 (ohms/ph)	Xm (ohms/ph)	VIBRATION (in/sec)	FLOAT
0.064	0.04	0.364	0.487	11.723	0.080	ODE

* N O T E S *		If Inverter equals NONE, contact factory for further information INVERTER TORQUE: VARIABLE 10:1 INV. HP SPEED RANGE: NONE
	ENCODER: NONE	
	NONE	
	NONE PPR	

PREPARED BY: ANUSHAM	BRAKE: NONE
DATE: 3/18/2020	NONE NONE
	FT-LB: NA
	VOLTAGE: NONE HZ:

FORM: 3531 REV_4 2/27/06
 ** Subject to change without notice.

Data Sheet

Date: 3/10/2020
 Customer: _____
 Attention: _____
 Submitted by: ANUSHA M



364THFCD9036

Submittal
 Data @ 460 V

Motor Load Data								
Load	0%	25%	50%	75%	100%	115%	125%	LR
Current (Amps)	22.5	27.8	39.0	53.2	69.0	79.5	86.5	435
Torque (ft-lb)	0.00	44.0	88.0	132	177	204	222	354
RPM	1800	1795	1790	1785	1782	1780	1775	0
Efficiency (%)		93.0	95.0	95.4	95.0	95.0	94.5	
P.F. (%)	4.0	54.5	75.5	83.0	85.5	86.0	86.0	33.0

Motor Speed Data						Information Block				
	LR	Pull-Up	BD	Rated	Idle					
Speed (RPM)	0	900	1715	1782	1800	HP	60.0			
Current (Amps)	435	350	238	69.0	22.5	Sync. RPM	1800			
Torque (ft-lb)	354	297	451	177	0.00	Frame	364			
						Enclosure	TEFC			
						Construction	TFC			
						Voltage	460 V			
						Frequency	60 Hz			
						Design	B			
						LR Code letter	G			
						Service Factor	1.15			
						Temp Rise @ FL	55 °C			
						Duty	CONT			
						Ambient	50 °C			
						Elevation	1,000 feet			
						Rotor/Shaft wk ²	17.2 Lb-FT ²			
						Ref Wdg	HE32254010 NONE			
						Sound Pressure @ 1M	72 dBA			
						VFD Rating	VARIABLE 10:1			
						Outline Dwg	SS557662-364T			
						Conn. Diag	EE7300U			
						Additional Specifications:				
						0				
						EQUIV CKT (OHMS / PHASE)				
						R1	R2	X1	X2	Xm
						0.0640	0.0400	0.3640	0.4870	11.7230

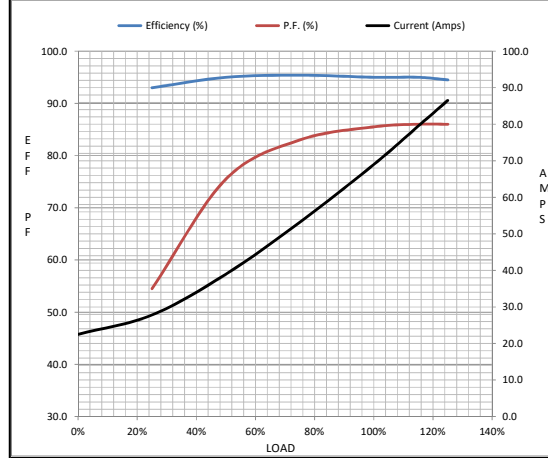

HP	60.0			
Sync. RPM	1800			
Frame	364			
Enclosure	TEFC			
Construction	TFC			
Voltage	460 V			
Frequency	60 Hz			
Design	B			
LR Code letter	G			
Service Factor	1.15			
Temp Rise @ FL	55 °C			
Duty	CONT			
Ambient	50 °C			
Elevation	1,000 feet			
Rotor/Shaft wk ²	17.2 Lb-FT ²			
Ref Wdg	HE32254010 NONE			
Sound Pressure @ 1M	72 dBA			
VFD Rating	VARIABLE 10:1			
Outline Dwg	SS557662-364T			
Conn. Diag	EE7300U			
Additional Specifications:				
0				
EQUIV CKT (OHMS / PHASE)				
R1	R2	X1	X2	Xm
0.0640	0.0400	0.3640	0.4870	11.7230

