

PRODUCT INFORMATION PACKET

Model No: 364TSHFCD9001
Catalog No: W584A
60 HP, Severe Duty Motors, 3 phase, 3600 RPM, 460 V, 364TS Frame, TEFC
Other Severe Duty Motors



Regal and Marathon are trademarks of Regal Beloit Corporation or one of its affiliated companies.
©2020 Regal Beloit Corporation, All Rights Reserved. MC017097E

REGAL



Nameplate Specifications

Output HP	60 Hp	Output KW	45.0 kW
Frequency	60 Hz	Voltage	460 V
Current	67.5 A	Speed	3568 rpm
Service Factor	1.15	Phase	3
Efficiency	93.6 %	Power Factor	89
Duty	Continuous	Insulation Class	H
Design Code	B	KVA Code	G
Frame	364TS	Enclosure	Totally Enclosed Fan Cooled
Thermal Protection	No	Ambient Temperature	40 °C
Drive End Bearing Size	6313	Opp Drive End Bearing Size	6213
UL	Listed	CSA	Y
CE	Y	IP Code	56
Hazardous Location	DIVISION 2 T2B		

Technical Specifications

Electrical Type	Squirrel Cage Inverter Rated	Starting Method	Line Or Inverter
Poles	2	Rotation	Selective Clockwise
Resistance Main	.1034 Ohms	Mounting	Rigid Base
Motor Orientation	Horizontal	Drive End Bearing	Ball
Opp Drive End Bearing	Ball	Frame Material	Cast Iron
Shaft Type	TS	Shaft Diameter	1.875 in
Assembly/Box Mounting	F1/F2 CAPABLE		
Connection Drawing	EE7300U	Outline Drawing	SS557663-364TS

This is an uncontrolled document once printed or downloaded and is subject to change without notice. Date Created:20/08/2020

4

3

2

1

OUTLINE

B

B

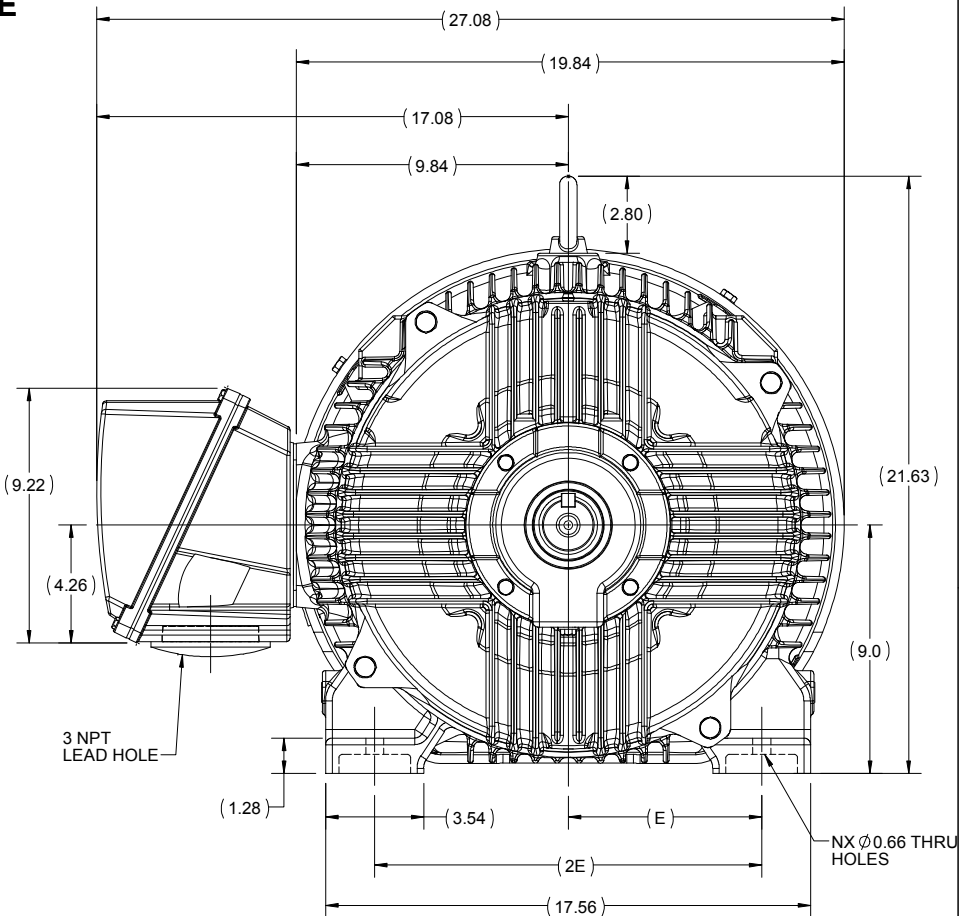
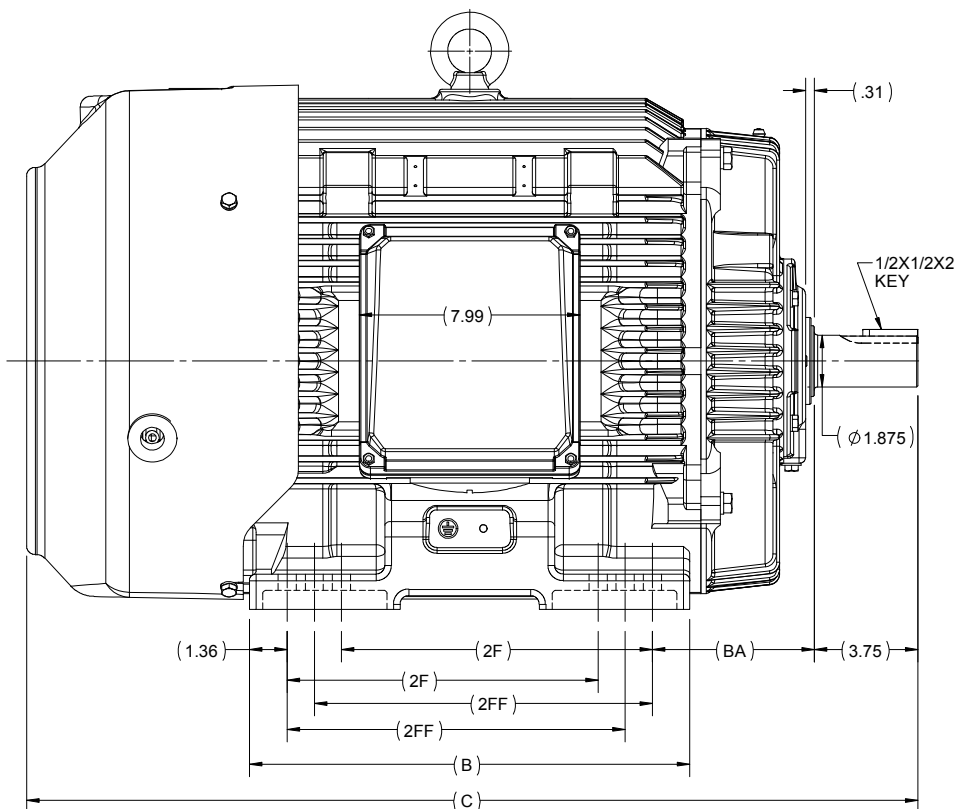

A

A

364/365TS	15.94	32.27	12.25	11.25	5.88	7.00	14.00	12	F1 OR F2
364TS	14.96	31.29	11.25	-				8	F1 OR F2
FRAME	B	C	2FF	2F	BA	E	2E	N	MOUNTING

DRAWING REVISION B	REVISION BY BISWA	DATE 25/01/2019
ECO ECO-0160791	APPROVED BY SBD	DATE 25/01/2019
ECO DESCRIPTION DRAWING UPDATED		
<small>COPYRIGHT REGAL BELOIT AMERICA, INC. ALL RIGHTS RESERVED. PROPRIETARY AND CONFIDENTIAL INFORMATION - THIS DOCUMENT IS THE PROPERTY OF REGAL BELOIT AMERICA, INC. ("OWNER") AND CONTAINS OWNER'S PROPRIETARY INFORMATION. ANY PERSON, CORPORATION OR OTHER FIRM RECEIVING IT IS DEEMED, BY RECEIVING IT, TO AGREE THAT IT, AND/OR ANY PART OF IT, SHALL NOT BE DISCLOSED TO ANY PERSON, CORPORATION OR OTHER ENTITY, DUPLICATED, AND/OR USED, EXCEPT AS EXPRESSLY APPROVED IN WRITING IN ADVANCE BY OWNER. THIS DOCUMENT SHALL BE RETURNED TO OWNER UPON REQUEST. IT MAY BE SUBJECT TO CERTAIN RESTRICTIONS UNDER APPLICABLE EXPORT CONTROL LAWS AND REGULATIONS.</small>		

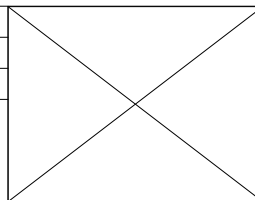

DRAWN BY BISWA	Regal Beloit America, Inc.
DATE 24/12/2018	
APPROVED BY SBD	DESCRIPTION OUTLINE 364/365TS FR-NEMA-SD & IEEE841
DATE 24/12/2018	MATERIAL
REFERENCE	PROCESS/FINISH
THIRD ANGLE PROJECTION	SIZE B
	DRAWING NUMBER SS557663
	SHEET 1 OF 1

4

3

2

1

IF MOTOR HAS 9 LEADS

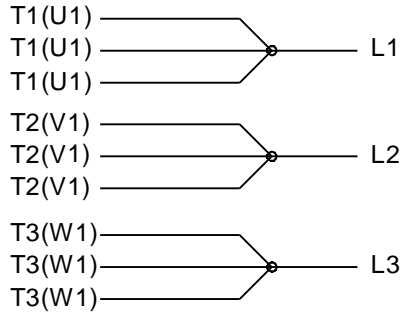

IF MOTOR HAS 6 LEADS



A-9806 DECAL IF CALLED FOR

IF MOTOR HAS 12 LEADS



VIEW OF TERMINAL END

DRAWING REVISION L	REVISION BY AJW	DATE 05-04-2015	TOLERANCES UNLESS OTHERWISE SPECIFIED:	DRAWN BY DRS	Regal Beloit America, Inc.																					
ECO ECO-0077067	APPROVED BY EWH	DATE 05-05-2015	<table style="font-size: small; border-collapse: collapse;"> <tr> <td><u>DEC.</u></td> <td><u>INCH</u></td> <td><u>mm</u></td> <td><u>ANGLE</u></td> </tr> <tr> <td>.X</td> <td>±0.1</td> <td>[±2.5]</td> <td>±7' 30"</td> </tr> <tr> <td>.XX</td> <td>±0.02</td> <td>[±0.51]</td> <td></td> </tr> <tr> <td>.XXX</td> <td>±0.005</td> <td>[±0.127]</td> <td></td> </tr> <tr> <td>.XXXX</td> <td>±0.0005</td> <td>[±0.0127]</td> <td></td> </tr> </table>	<u>DEC.</u>			<u>INCH</u>	<u>mm</u>	<u>ANGLE</u>	.X	±0.1	[±2.5]	±7' 30"	.XX	±0.02	[±0.51]		.XXX	±0.005	[±0.127]		.XXXX	±0.0005	[±0.0127]		DATE 09-27-1996
<u>DEC.</u>	<u>INCH</u>	<u>mm</u>	<u>ANGLE</u>																							
.X	±0.1	[±2.5]	±7' 30"																							
.XX	±0.02	[±0.51]																								
.XXX	±0.005	[±0.127]																								
.XXXX	±0.0005	[±0.0127]																								
ECO DESCRIPTION UPDATED TO SOLIDWORKS			APPROVED BY GK	DATE 09-30-1996	MATERIAL	PROCESS/FINISH																				
COPYRIGHT REGAL BELOIT AMERICA, INC. ALL RIGHTS RESERVED. PROPRIETARY AND CONFIDENTIAL INFORMATION - THIS DOCUMENT IS THE PROPERTY OF REGAL BELOIT AMERICA, INC. ("OWNER") AND CONTAINS OWNER'S PROPRIETARY INFORMATION. ANY PERSON, CORPORATION OR OTHER FIRM RECEIVING IT IS DEEMED, BY RECEIVING IT, TO AGREE THAT IT, AND/OR ANY PART OF IT, SHALL NOT BE DISCLOSED TO ANY PERSON, CORPORATION OR OTHER ENTITY, DUPLICATED, AND/OR USED, EXCEPT AS EXPRESSLY APPROVED IN WRITING IN ADVANCE BY OWNER. THIS DOCUMENT SHALL BE RETURNED TO OWNER UPON REQUEST. IT MAY BE SUBJECT TO CERTAIN RESTRICTIONS UNDER APPLICABLE EXPORT CONTROL LAWS AND REGULATIONS.			REMOVE BURRS & BREAK SHARP EDGES: .003/.015 [.076/.381] X 45° CORNER FILLETS: R.02 [.51] MACHINED SURFACES: 200 $\sqrt{\text{INCH}}$ 5.1 $\sqrt{\text{mm}}$ mm SHOWN IN [BRACKETS]	REFERENCE	SIZE A	DRAWING NUMBER EE7300U	SHEET 1 OF 1																			
				THIRD ANGLE PROJECTION																						



DATA VOLTS: 460

CERTIFICATION DATA SHEET

CONN. DIAGRAM: EE7300U
 OUTLINE: SS557663-364TS
 WINDING: HE32252006 NONE 1

MODEL #: 364TSHFCD9001
 CAT #: W584A
 MOUNTING: F1/F2 CAPABLE

TYPICAL MOTOR PERFORMANCE DATA

HP	KW	SYNC RPM	FL RPM	FRAME	ENCLOSURE	TYPE	KVA CODE	DESIGN
60	45	3600	3568	364TS	TEFC	TFC	G	B

PH	HZ	VOLTS	AMPS	START TYPE	DUTY	INSL	S.F.	AMB (° C)	ELEV.(Ft)
3	60	460	67.5	LINE OR INVERTER	CONT	H	1.15	40	3300

F.L. EFF	93.6	3/4 LD EFF	93.6	1/2 LD EFF	91.7	GTD EFF	ELECT. TYPE
F.L. PF	89.0	3/4 LD PF	87.0	1/2 LD PF	80.5	93.0	SQ CAGE INV RATED

F.L. TORQUE	LR AMPS @ 460 V	L.R. TORQUE	B.D. TORQUE	F.L. RISE (° C)
88.0 LB-FT	435	150 LB-FT	238 LB-FT	65

SOUND PRESSURE @	SOUND	ROTOR WK ¹	MAX. LOAD WK ¹	SAFE STALL TIME	STARTS/HOUR	APROX. MOTOR
80 dBA	89 dBA	8.5 LB-FT ²	40 LB-FT ²	20 SEC.	2	833 LB.

*** SUPPLEMENTAL INFORMATION ***

DE BRACKET TYPE	ODE BRACKET TYPE	MOUNT TYPE	MOTOR ORIENTATION	SEVERE DUTY	HAZARDOUS LOCATION	DRIP COVER	SCREENS	PAINT
STANDARD	STANDARD	RIGID	HORIZONTAL	PREMIUM SEVERE DUTY	DIVISION 2 T2B	NO	NONE	BLUE (EPOXY)

BEARINGS		GREASE	SHAFT TYPE	SPECIAL DE	SPECIAL ODE	SHAFT	MATERIAL	FRAME MATERIAL
DE	ODE							
BALL	BALL	POLYREX EM	TS	NONE	NONE	1045 HOT ROLLED (C-204)		CAST IRON
6313	6213							

THERMOSTATS	PROTECTORS	WDG RTD's	BRG RTD's	THERMISTORS	CONTROL	SPACE HEATERS
NONE	NOT	NONE	NONE	NONE	FALSE	NA

R1 (ohms/ph)	R2 (ohms/ph)	X1 (ohms/ph)	X2 (ohms/ph)	Xm (ohms/ph)	VIBRATION (in/sec)
0.065	0.037	0.359	0.444	13.236	0.080

If Inverter equals NONE, contact factory for further information

* N O T E S *		INVERTER TORQUE: VARIABLE 10:1
		INV. HP SPEED RANGE: NONE
		ENCODER: NONE
		NONE NONE NONE PPR
		BRAKE: NONE NONE NONE

PREPARED BY: ANUSHA M
 DATE: 3/10/2020
 FT-LB: NA
 VOLTAGE: NONE HZ:

FORM: 3531 REV_4 2/27/06
 ** Subject to change without notice.

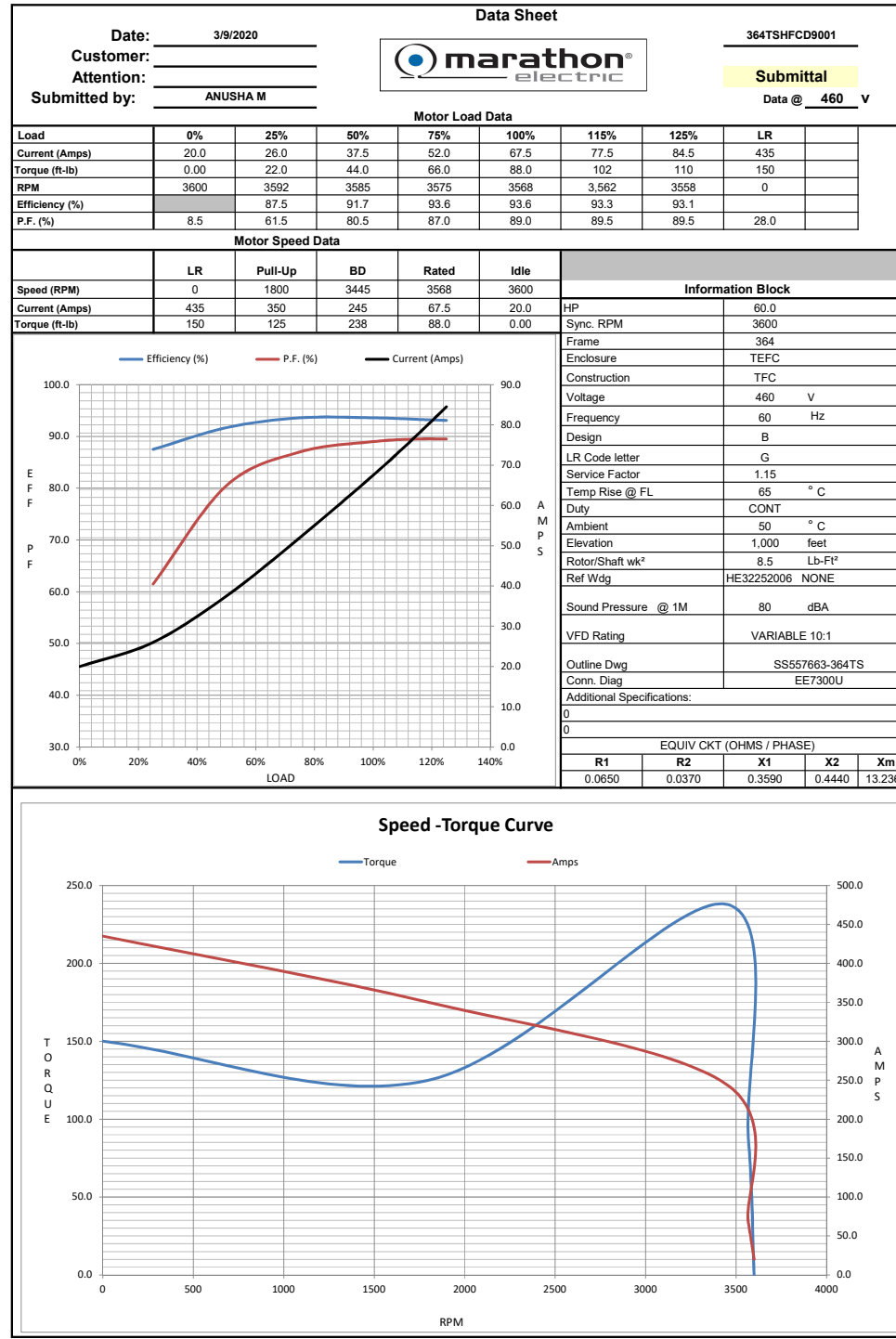

6 of 6