

PRODUCT INFORMATION PACKET

Model No: 284THFNA19048
Catalog No: W560-P
25,1800,TEC,284T,3/60/460
Severe Duty



Regal and Marathon are trademarks of Regal Beloit Corporation or one of its affiliated companies.
©2018 Regal Beloit Corporation, All Rights Reserved. MC017097E





Nameplate Specifications

Output HP	25 Hp	Output KW	18.7 kW
Frequency	60 Hz	Voltage	460 V
Current	31 A	Speed	1772 rpm
Service Factor	1.15	Phase	3
Efficiency	93.6 %	Duty	CONTINUOUS
Insulation Class	F	Design Code	B
KVA Code	G	Frame	284T
Enclosure	TEFC	Overload Protector	NOT
Ambient Temperature	40 °C	Drive End Bearing Size	6311
Opp Drive End Bearing Size	6210	UL	Recognized
CSA	Y	CE	Y
IP Code	56		

Technical Specifications

Electrical Type	SQ CAGE INV RATED	Starting Method	LINE OR INVERTER
Poles	4	Rotation	REV
Mounting	RIGID	Motor Orientation	HORIZONTAL
Drive End Bearing	BALL	Opp Drive End Bearing	BALL
Frame Material	CAST IRON	Shaft Type	T
Overall Length	26.21 in	Frame Length	12.75 in
Shaft Diameter	1.88 in	Shaft Extension	4.82 in
Assembly/Box Mounting	F1/F2 CAPABLE		
Outline Drawing	B-SS311057-1275	Connection Diagram	A-EE7300

This is an uncontrolled document once printed or downloaded and is subject to change without notice. Date Created: 04/05/2018

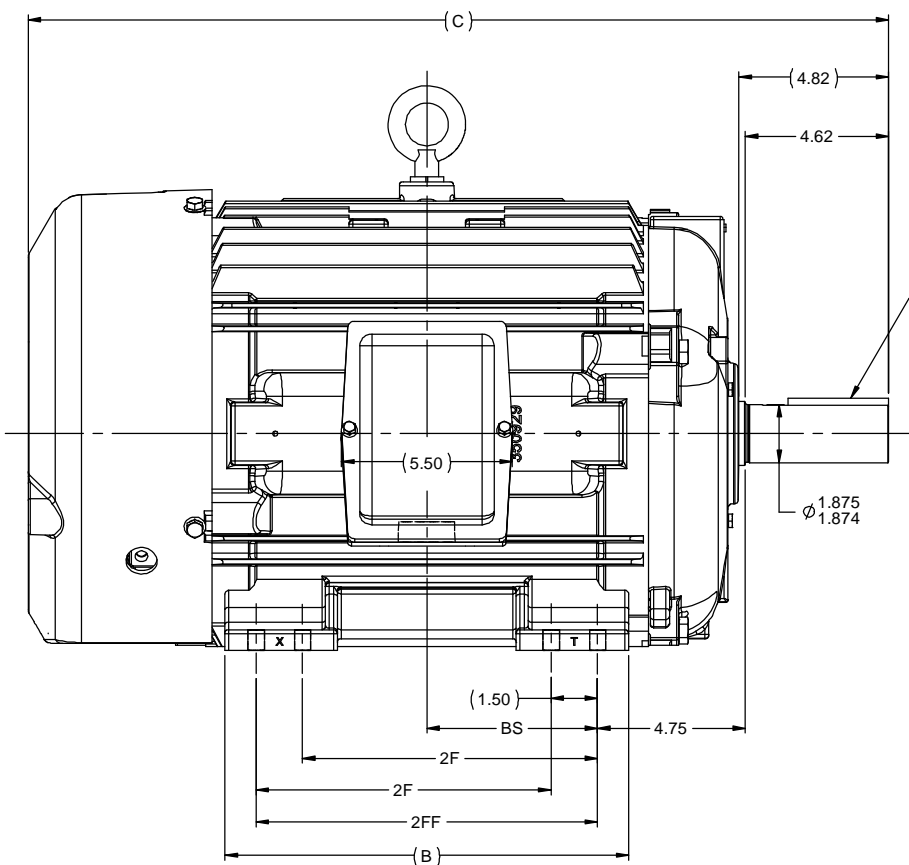

1/2x1/2x3.25 KEY

Ø 1.875
1.874

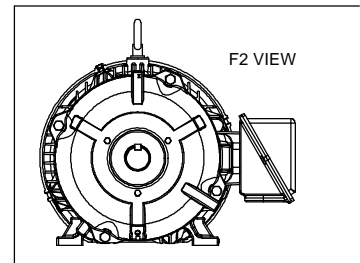
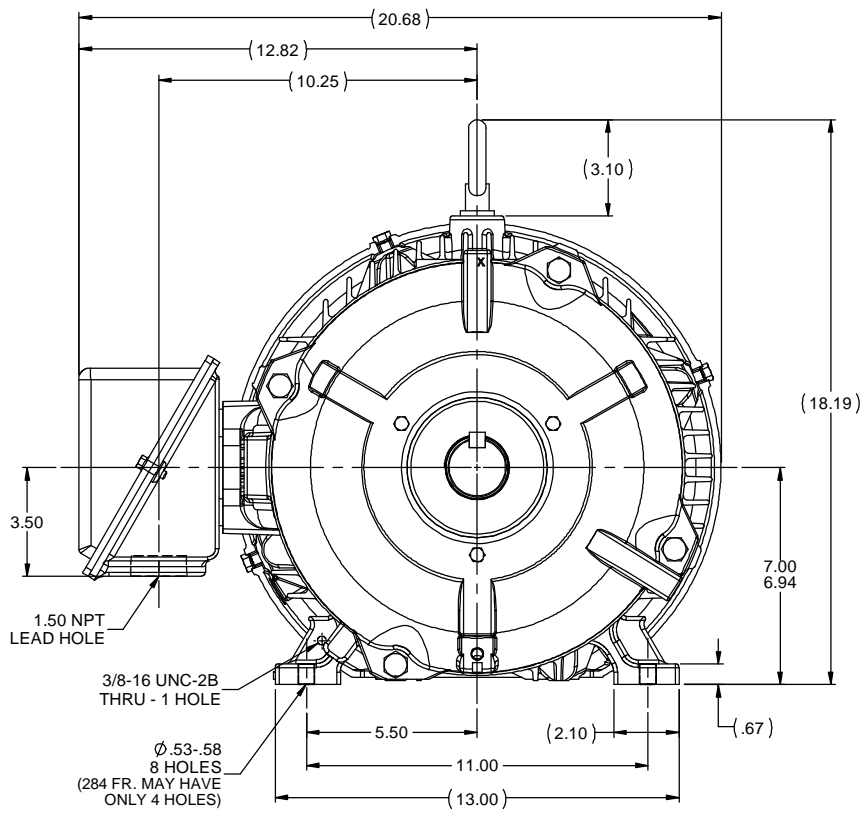

- NOTES:
 1. CONDUIT BOX CAN BE ROTATED UP TO 270 ° FROM ITS ORIGINAL POSITION.
 2. CONDUIT BOX CAN BE MOUNTED ON OPPOSITE SIDE BY REMOVING BRACKETS AND TURNING FRAME 180 °.
 3. NAMEPLATE TO BE READ FROM CONDUIT BOX SIDE OF MOTOR.

1275	284T	26.21	12.50	9.50	---	4.75
1425	284/286T	27.71	13.00	9.50	11.00	5.50
DASH	FRAME	C	B	2F	2FF	BS

		TOLERANCES UNLESS SPECIFIED		marathon electric		DRAWN CAV 10-18-2000	
		DEC	INCHES			CHK ML 10-18-2000	APPR BW 10-18-2000
4	UPDATED TO NEW FRAME DESIGN MU106205	MSG 08-22-2012	MSG x	±.1			
3	REDRAWN IN AUTOCAD - NO CHANGE	TAT 06-29-2004	ML xx	±.03	TITLE OUTLINE - TEFC - TGN		SCALE 1:4
2	ADDED NOTE 3 MU35810	DAH 02-06-2001	ML xxx	±.005	280T FR. - BB - STD - 12.50 LAM.		REF
1	NEW DRAWING MU34031	MSG 08-23-2012	ML xxxxx	±.0005	MATL		FMF MU34031
NO	REVISION	BY & DATE	CHK LANG	±1/2°	FINISH		PAGE OF
					PREV		
					NETWORK FILE NAME SS311057		
						SIZE B	DRAWING NO SS311057
							REV 4



**THREE PHASE - SINGLE VOLTAGE
MOTOR - CONDUIT BOX @ 'A'**

**TO REVERSE ROTATION:
INTERCHANGE ANY TWO
LINE LEAD CONNECTIONS.**

TERMINAL BLOCK WHEN SPECIFIED

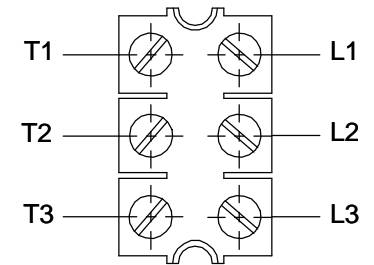

VIEW OF TERMINAL END

**IF MOTOR HAS
6 LEADS**



A-9806 DECAL

**OPTIONAL CORD
CONNECTION**



DRAWING REVISION AB	REVISION BY JJB	DATE 06-27-2017
ECO ECO-0125361	APPROVED BY TB	DATE 06-27-2017
ECO DESCRIPTION UPDATED TO CURRENT STANDARDS		
<small>COPYRIGHT REGAL BELOIT AMERICA, INC. ALL RIGHTS RESERVED. PROPRIETARY AND CONFIDENTIAL INFORMATION - THIS DOCUMENT IS THE PROPERTY OF REGAL BELOIT AMERICA, INC. ("OWNER") AND CONTAINS OWNER'S PROPRIETARY INFORMATION. ANY PERSON, CORPORATION OR OTHER FIRM RECEIVING IT IS DEEMED, BY RECEIVING IT, TO AGREE THAT IT, AND/OR ANY PART OF IT, SHALL NOT BE DISCLOSED TO ANY PERSON, CORPORATION OR OTHER ENTITY, DUPLICATED, AND/OR USED, EXCEPT AS EXPRESSLY APPROVED IN WRITING IN ADVANCE BY OWNER. THIS DOCUMENT SHALL BE RETURNED TO OWNER UPON REQUEST. IT MAY BE SUBJECT TO CERTAIN RESTRICTIONS UNDER APPLICABLE EXPORT CONTROL LAWS AND REGULATIONS.</small>		



DRAWN BY DA
DATE 03-26-1993
APPROVED BY TB
DATE 03-26-1993
REFERENCE
THIRD ANGLE PROJECTION

Regal Beloit America, Inc.		
		DESCRIPTION CONNECTION DIAGRAM EXTERNAL - SINGLE VOLTAGE - 3Ø MOTOR
MATERIAL	PROCESS/FINISH	
SIZE A	DRAWING NUMBER EE7300	SHEET 1 OF 1

CERTIFICATION DATA SHEET

Model#: 284THFNA19048 AA **WINDING#:** K2844161 NONE 1
CONN. DIAGRAM: A-EE7300 **ASSEMBLY:** F1/F2 CAPABLE
OUTLINE: B-SS311057-1275

TYPICAL MOTOR PERFORMANCE DATA

HP	KW	SYNC. RPM	F.L. RPM	FRAME	ENCLOSURE	KVA CODE	DESIGN
25	18.7	1800	1772	284T	TEFC	G	B

PH	Hz	VOLTS	FL AMPS	START TYPE	DUTY	INSL	S.F	AMB°C	ELEVATION
3	60	460	31	LINE OR INVERTER	CONTINUOUS	F3	1.15	40	3300

FULL LOAD EFF: 93.6	3/4 LOAD EFF: 94.1	1/2 LOAD EFF: 93.6	GTD. EFF	ELEC. TYPE	NO LOAD AMPS
FULL LOAD PF: 81	3/4 LOAD PF: 76	1/2 LOAD PF: 65.5	93	SQ CAGE INV RATED	13

F.L. TORQUE	LOCKED ROTOR AMPS	L.R. TORQUE	B.D. TORQUE	F.L. RISE°C
74 LB-FT	182	138 LB-FT 186	185 LB-FT 250	60

SOUND PRESSURE @ 3 FT.	SOUND POWER	ROTOR WK^2	MAX. WK^2	SAFE STALL TIME	STARTS /HOUR	APPROX. MOTOR WGT
65 dBA	75 dBA	4.2 LB-FT^2	175 LB-FT^2	50 SEC.	2	475 LBS.

***** SUPPLEMENTAL INFORMATION *****

DE BRACKET TYPE	ODE BRACKET TYPE	MOUNT TYPE	ORIENTATION	SEVERE DUTY	HAZARDOUS LOCATION	DRIP COVER	SCREENS	PAINT
STANDARD	STANDARD	RIGID	HORIZONTAL	PREMIUM SEVERE DUTY	NONE	FALSE	NONE	BLUE (EPOXY)

BEARINGS		GREASE	SHAFT TYPE	SPECIAL DE	SPECIAL ODE	SHAFT MATERIAL	FRAME MATERIAL
DE	OPE						
BALL	BALL	POLYREX EM	T	NONE	NONE	1045 HOT ROLLED (C-204)	CAST IRON
6311	6210						

THERMO-PROTECTORS				THERMISTORS	CONTROL	SPACE /n HEATERS
THERMOSTATS	PROTECTORS	WDG RTDs	BRG RTDs			
NONE	NOT	NONE	NONE	NONE	FALSE	NONE VOLTS

If Inverter equals NONE, contact factory for further information

INVERTER TORQUE: CONSTANT 20:1
INV. HP SPEED RANGE: NONE
ENCODER: NONE
NONE NONE
NONE NONE PPR
BRAKE: NONE NONE
NONE P/N NONE
NONE NONE
NONE FT-LB NONE V NONE Hz

*
N
O
T
E
S
*

DATE: 06/21/2017 09:49:07 AM
 FORM 3531 REV.3 02/07/99

** Subject to change without notice.

Data Sheet

Date: 15-06-2017
 Customer: _____
 Attention: _____
 Submitted by: FAREEDA DUDEKULA



284THFNA19048

Submittal

Data @ 460 V

Motor Load Data

Load	0%	25%	50%	75%	100%	115%	125%	LR
Current (Amps)	13.0	15.0	19.1	24.6	31.0	35.0	40.0	182
Torque (ft-lb)	0.00	18.3	37.0	55.5	74.0	85.5	93.0	138
RPM	1800	1793	1787	1780	1772	1,767	1763	0
Efficiency (%)		90.2	93.6	94.1	93.6	93.0	93.0	
P.F. (%)	3.0	43.0	65.5	76.0	81.0	82.5	83.0	33.0

Motor Speed Data

	LR	Pull-Up	BD	Rated	Idle
Speed (RPM)	0	900	1662	1772	1800
Current (Amps)	182	169	108	31.0	13.0
Torque (ft-lb)	138	117	185	74.0	0.00

Information Block

HP	25.0			
Sync. RPM	1800			
Frame	284			
Enclosure	TEFC			
Construction	TFN			
Voltage	460 V			
Frequency	60 Hz			
Design	B			
LR Code letter	G			
Service Factor	1.15			
Temp Rise @ FL	60 ° C			
Duty	CONT			
Ambient	40 ° C			
Elevation	1,000 feet			
Rotor/Shaft wk ²	4.2 Lb-Ft ²			
Ref Wdg	K2844161 NONE			
Sound Pressure @ 1M	65 dBA			
VFD Rating	CONSTANT 20:1			
Outline Dwg	B-SS311057-1275			
Conn. Diag	A-EE7300			
Additional Specifications:				
0				
365THFS8036				
EQUIV CKT (OHMS / PHASE)				
R1	R2	X1	X2	Xm
0.1810	0.1570	0.8480	1.0850	19.7750

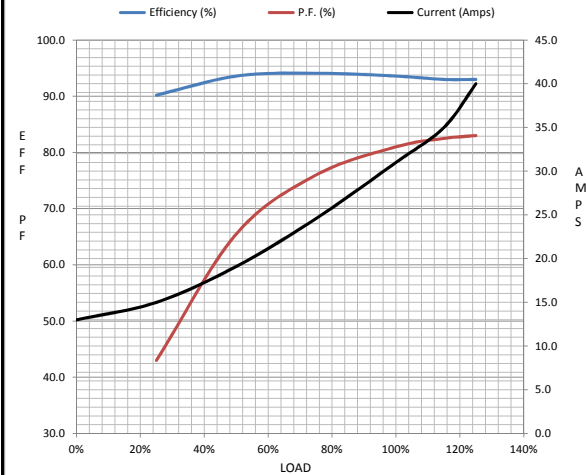

Speed -Torque Curve

