

PRODUCT INFORMATION PACKET

Model No: 215TTDW16061
Catalog No: U433A
10,1800,DP,215TC,3/60/230/460
Open Drip Proof (ODP)



Regal and Marathon are trademarks of Regal Beloit Corporation or one of its affiliated companies.
©2018 Regal Beloit Corporation, All Rights Reserved. MC017097E





Nameplate Specifications

Output HP	10 Hp	Output KW	7.5 kW
Frequency	60 Hz	Voltage	230/460 V
Current	25/12.5 A	Speed	1760 rpm
Service Factor	1.15	Phase	3
Efficiency	91.7 %	Duty	CONTINUOUS
Insulation Class	B	Design Code	B
KVA Code	G	Frame	215TC
Enclosure	DP	Overload Protector	NOT
Ambient Temperature	40 °C	Drive End Bearing Size	6309
Opp Drive End Bearing Size	6206	UL	Recognized
CSA	Y	CE	Y
IP Code	22		

Technical Specifications

Electrical Type	SQ CAGE IND RUN	Starting Method	PWS(LV ONLY) & YDRUN
Poles	4	Rotation	REV
Mounting	RIGID	Motor Orientation	HORIZONTAL
Drive End Bearing	BALL	Opp Drive End Bearing	BALL
Frame Material	ROLLED STEEL	Shaft Type	T
Overall Length	19.28 in	Frame Length	12.4 in
Shaft Diameter	1.38 in	Shaft Extension	3.12 in
Assembly/Box Mounting	F1/F2 CAPABLE		
Outline Drawing	A-SS86614-1240	Connection Diagram	A-EE7358

SS86614

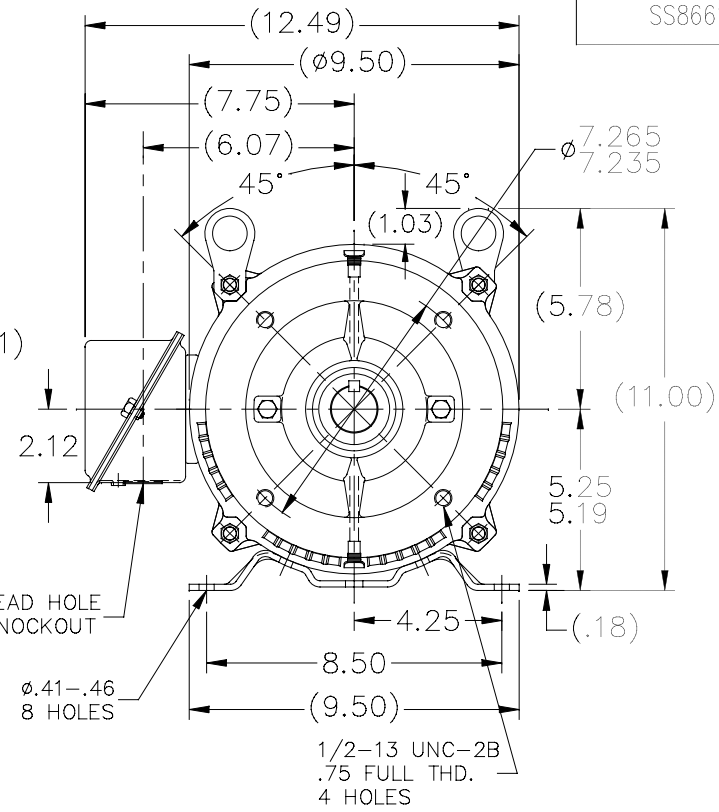
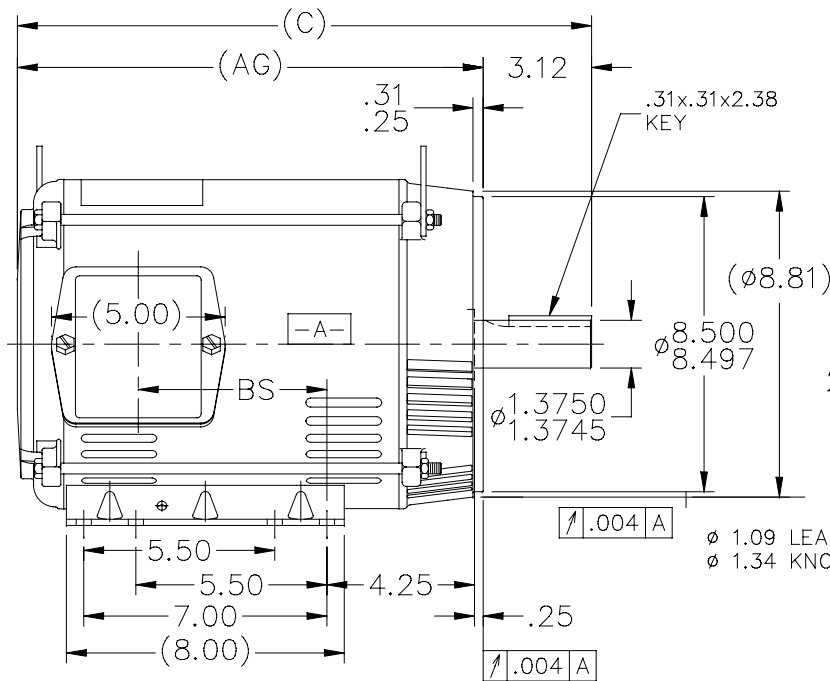

NOTES:

1. NAMEPLATE TO BE READ FROM CONDUIT BOX SIDE OF MOTOR.
2. CONDUIT BOX CAN BE MOUNTED IN 90° STEPS.
3. CONDUIT BOX CAN BE MOUNTED ON OPPOSITE SIDE BY REMOVING BRACKETS AND TURNING FRAME 180. (EXCEPT AS NOTED)

DASH	FRAME	C	AG	BS	MOUNTING
965	213T	16.53	13.41	5.43	
1115	213/15T	18.03	14.91	6.93	
1240	213/15T	19.28	16.16	8.18	F1 ONLY

NO.	REVISION	BY & DATE	CHK	ANG	±'30"
5	TITLE BLOCK LOGO CHANGE PER ECO-0078542	MDV 06/09/2015			
4	UPDATED DRAWING	TJW 04/30/2007			
3	REDRAWN IN AUTOCAD	TAT 06-29-2004	ML	.XX	±.03
2	UPDATED C' BOX GEOMETRY	CN 28425 HLB 11-13-2000		.XXX	±.005
1	NEW DRAWING - DES/DEV	MRB 05-22-1996		.XXXX	±.0005

TOLERANCES UNLESS SPECIFIED	
DEC.	INCHES
.X	±.1
.XX	±.03
.XXX	±.005
.XXXX	±.0005
ANG	±'30"

REGAL™ Regal Beloit America, Inc.

TITLE OUTLINE - C' FACE
210T FR. - BB - TS - DR.PR.

MAT'L.

FINISH

DRAWN MRB 05-07-1996
CHK ML 05-20-1996
APPD DN 05-20-1996
SCALE 7=32
REF
FMF
PREV

THIS DRAWING IN DESIGN AND DETAIL IS OUR PROPERTY AND MUST NOT BE USED EXCEPT IN CONNECTION WITH OUR WORK ALL RIGHTS OF DESIGN AND INVENTION ARE RESERVED THIS IS AN ELECTRONICALLY GENERATED DOCUMENT - DO NOT SCALE THIS PRINT

RFP	CAD FILE ss86614
DIST LB	

SIZE A	DRAWING NO. SS86614	PAGE OF	REV. 5
--------	---------------------	---------	--------

HIGH VOLTAGE

WYE START

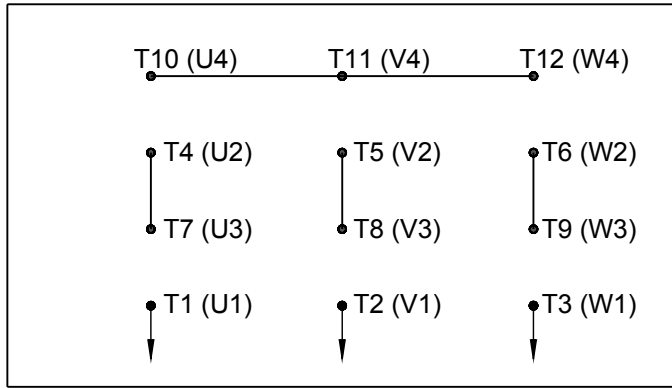

DELTA RUN

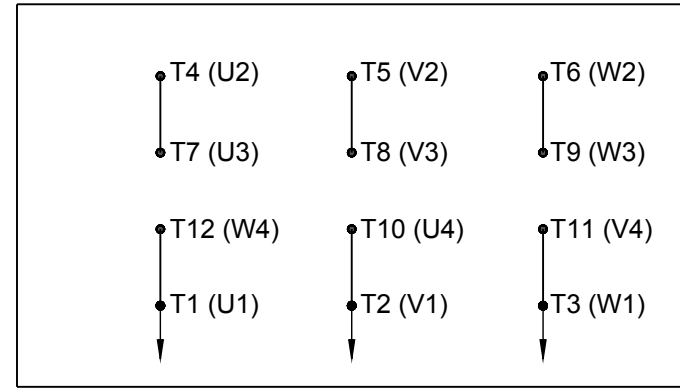

WYE START

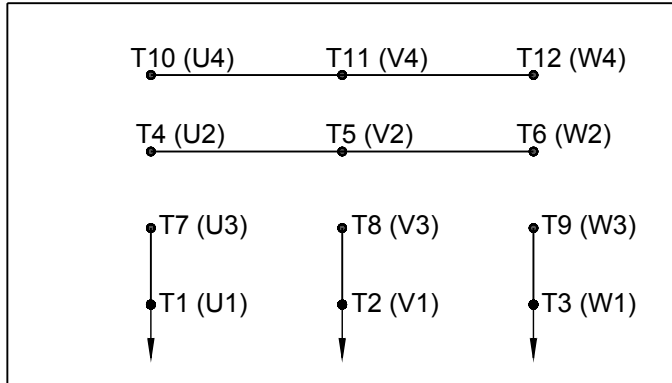

LOW VOLTAGE

DELTA RUN

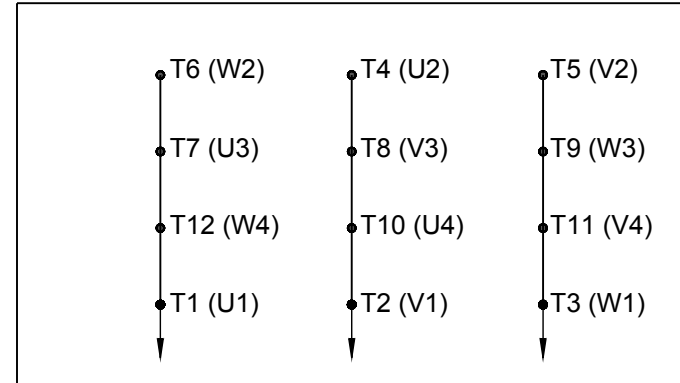

4/2 CKTY \triangle

DRAWING REVISION D	REVISION BY JWO	DATE 01-26-2016
-----------------------	--------------------	--------------------

ECO ECO-0092547	APPROVED BY TB	DATE 01-26-2016
--------------------	-------------------	--------------------

ECO DESCRIPTION
ADDED IEC MARKINGS

COPYRIGHT REGAL BELOIT AMERICA, INC. ALL RIGHTS RESERVED. PROPRIETARY AND CONFIDENTIAL INFORMATION - THIS DOCUMENT IS THE PROPERTY OF REGAL BELOIT AMERICA, INC. ("OWNER") AND CONTAINS OWNER'S PROPRIETARY INFORMATION. ANY PERSON, CORPORATION OR OTHER FIRM RECEIVING IT IS DEEMED, BY RECEIVING IT, TO AGREE THAT IT, AND/OR ANY PART OF IT, SHALL NOT BE DISCLOSED TO ANY PERSON, CORPORATION OR OTHER ENTITY, DUPLICATED, AND/OR USED, EXCEPT AS EXPRESSLY APPROVED IN WRITING IN ADVANCE BY OWNER. THIS DOCUMENT SHALL BE RETURNED TO OWNER UPON REQUEST. IT MAY BE SUBJECT TO CERTAIN RESTRICTIONS UNDER APPLICABLE EXPORT CONTROL LAWS AND REGULATIONS.

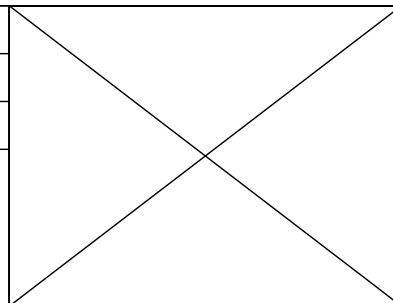

DRAWN BY BLR

DATE 03-09-1998

APPROVED BY GK

DATE 03-23-1998

REFERENCE

THIRD ANGLE PROJECTION

REGAL™ Regal Beloit America, Inc.

DESCRIPTION
CONN DIAGRAM-EXTERNAL
12 LEAD - DUAL VOLT. - WYE START - DELTA RUN

MATERIAL	PROCESS/FINISH
----------	----------------

SIZE A	DRAWING NUMBER EE7358	SHEET 1 OF 1
-----------	--------------------------	-----------------

CERTIFICATION DATA SHEET

Model#: 215TTDW16061 AA **WINDING#:** K2154306 NONE 5
CONN. DIAGRAM: A-EE7358 **ASSEMBLY:** F1/F2 CAPABLE
OUTLINE: A-SS86614-1240

TYPICAL MOTOR PERFORMANCE DATA

HP	KW	SYNC. RPM	F.L. RPM	FRAME	ENCLOSURE	KVA CODE	DESIGN
10&7 1/2	7.5&5.6	1800	1760&1465	215TC	DP	G	B

PH	Hz	VOLTS	FL AMPS	START TYPE	DUTY	INSL	S.F	AMB°C	ELEVATION
3	60/50	230/460#190/ 380	25/12.5&23.2/ 11.6	PWS(LV ONLY) & YDRUN	CONTINUOUS	B3	1.15/1.15	40	3300

FULL LOAD EFF: 91.7&91	3/4 LOAD EFF: 92.4	1/2 LOAD EFF: 92.4	GTD. EFF	ELEC. TYPE	NO LOAD AMPS
FULL LOAD PF: 81&80	3/4 LOAD PF: 77	1/2 LOAD PF: 67	90.2	SQ CAGE IND RUN	10 / 5

F.L. TORQUE	LOCKED ROTOR AMPS	L.R. TORQUE	B.D. TORQUE	F.L. RISE°C
29.8 LB-FT	152 / 76	63 LB-FT 211	81 LB-FT 272	38

SOUND PRESSURE @ 3 FT.	SOUND POWER	ROTOR WK^2	MAX. WK^2	SAFE STALL TIME	STARTS /HOUR	APPROX. MOTOR WGT
66 dBA	76 dBA	1 LB-FT^2	60 LB-FT^2	20 SEC.	2	155 LBS.

***** SUPPLEMENTAL INFORMATION *****

DE BRACKET TYPE	ODE BRACKET TYPE	MOUNT TYPE	ORIENTATION	SEVERE DUTY	HAZARDOUS LOCATION	DRIP COVER	SCREENS	PAINT
C-FACE	STANDARD	RIGID	HORIZONTAL	FALSE	NONE	FALSE	NONE	BLUE (ENAMEL)

BEARINGS		GREASE	SHAFT TYPE	SPECIAL DE	SPECIAL ODE	SHAFT MATERIAL	FRAME MATERIAL
DE	OPE						
BALL 6309	BALL 6206	POLYREX EM	T	NONE	NONE	1045 HOT ROLLED (C-204)	ROLLED STEEL

THERMO-PROTECTORS				THERMISTORS	CONTROL	SPACE /n HEATERS
THERMOSTATS	PROTECTORS	WDG RTDs	BRG RTDs			
NONE	NOT	NONE	NONE	NONE	FALSE	NONE VOLTS

If Inverter equals NONE, contact factory for further information

INVERTER TORQUE: NONE
INV. HP SPEED RANGE: NONE
ENCODER: NONE
NONE NONE
NONE NONE PPR
BRAKE: NONE NONE
NONE P/N NONE
NONE NONE
- FT-LB NONE V NONE Hz

*
N
O
T
E
S
*

DATE: 06/22/2017 07:24:14 AM
 FORM 3531 REV.3 02/07/99

** Subject to change without notice.

Data Sheet

Date: 19-06-2017
 Customer: _____
 Attention: _____
 Submitted by: FAREEDA DUDEKULA



215TTDW16061
Submittal
 Data @ 460 V

Motor Load Data									
Load	0%	25%	50%	75%	100%	115%	125%	LR	
Current (Amps)	5.0	5.7	7.5	10.0	12.5	14.5	15.5	76.0	
Torque (ft-lb)	0.00	7.4	14.8	22.2	29.8	34.5	37.5	63.0	
RPM	1800	1790	1782	1775	1760	1,755	1750	0	
Efficiency (%)		88.5	92.4	92.4	91.7	91.0	91.0		
P.F. (%)	5.0	46.0	67.0	77.0	81.0	82.0	82.5	41.5	

Motor Speed Data						Information Block	
	LR	Pull-Up	BD	Rated	Idle		
Speed (RPM)	0	750	1575	1760	1800	HP	10.0
Current (Amps)	76.0	72.0	44.5	12.5	5.0	Sync. RPM	1800
Torque (ft-lb)	63.0	57.0	81.0	29.8	0.00	Frame	215

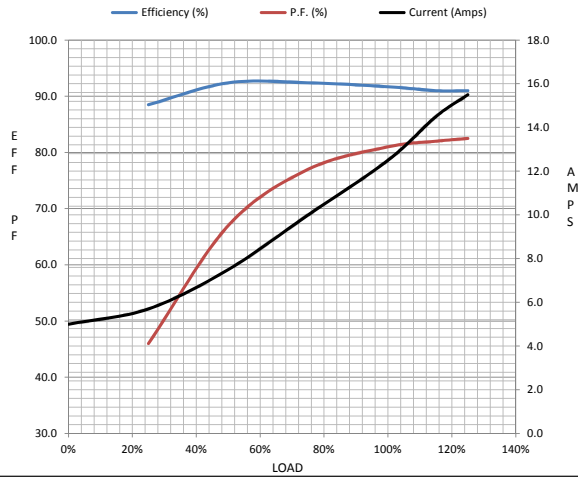

Enclosure	DP			
Construction	TDW			
Voltage	30/460#190/38V			
Frequency	60 Hz			
Design	B			
LR Code letter	G			
Service Factor	1.15			
Temp Rise @ FL	38 ° C			
Duty	CONT			
Ambient	40 ° C			
Elevation	1,000 feet			
Rotor/Shaft wk²	1.00 Lb-Ft²			
Ref Wdg	K2154306 NONE			
Sound Pressure @ 1M	66 dBA			
VFD Rating	NONE			
Outline Dwg	A-SS86614-1240			
Conn. Diag	A-EE7358			
Additional Specifications:				
0				
365THFS8036				
EQUIV CKT (OHMS / PHASE)				
R1	R2	X1	X2	Xm
0.5650	0.4490	2.0850	3.0760	47.2860

