

PRODUCT INFORMATION PACKET

Model No: 215TPNSB10235
Catalog No: SY009A
10,1800,TENV,215TC,3/60/230/460
SyMAX - Permanent Magnet AC Motors



Regal and Marathon are trademarks of Regal Beloit Corporation or one of its affiliated companies.
©2018 Regal Beloit Corporation, All Rights Reserved. MC017097E





Nameplate Specifications

Output HP	10 Hp	Output KW	7.5 kW
Frequency	90 Hz	Voltage	230/460 V
Current	24.6/12.3 A	Speed	1800 rpm
Service Factor	1	Phase	3
Efficiency	93.9 %	Duty	CONTINUOUS
Insulation Class	H	Design Code	PM
KVA Code	NO KVA CODE	Frame	215TC
Enclosure	TENV	Overload Protector	NOT
Ambient Temperature	40 °C	Drive End Bearing Size	6309
Opp Drive End Bearing Size	6208	UL	Recognized
CSA	N	CE	N
IP Code	54		

Technical Specifications

Electrical Type	AC PERMANENT MAGNET	Starting Method	INVERTER ONLY
Poles	6	Rotation	REV
Mounting	RIGID	Motor Orientation	HORIZONTAL
Drive End Bearing	BALL	Opp Drive End Bearing	BALL
Frame Material	CAST IRON	Shaft Type	T
Overall Length	20.41 in	Frame Length	9.12 in
Shaft Diameter	1.38 in	Shaft Extension	3.12 in
Assembly/Box Mounting	F1 ONLY		
Outline Drawing	037797-912	Connection Diagram	EE7308T

This is an uncontrolled document once printed or downloaded and is subject to change without notice. Date Created: 04/05/2018

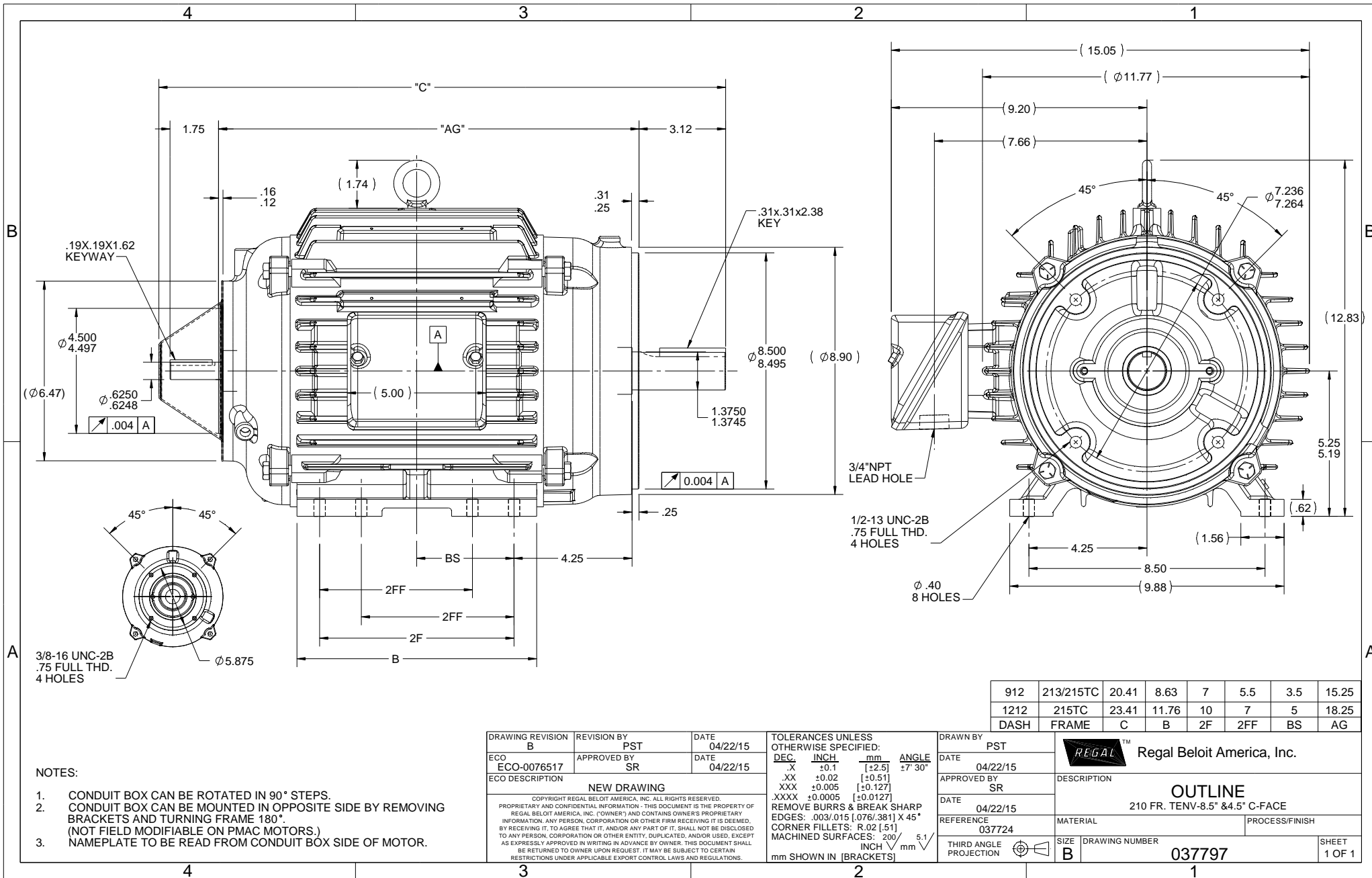

- NOTES:
1. CONDUIT BOX CAN BE ROTATED IN 90° STEPS.
 2. CONDUIT BOX CAN BE MOUNTED IN OPPOSITE SIDE BY REMOVING BRACKETS AND TURNING FRAME 180°.
(NOT FIELD MODIFIABLE ON PMAC MOTORS.)
 3. NAMEPLATE TO BE READ FROM CONDUIT BOX SIDE OF MOTOR.

DRAWING REVISION B	REVISION BY PST	DATE 04/22/15	TOLERANCES UNLESS OTHERWISE SPECIFIED: DEC INCH mm ANGLE .X ±0.1 [+2.5] ±7 30° .XX ±0.02 [+0.51] .XXX ±0.005 [+0.127] .XXXX ±0.0005 [+0.0127]
ECO-0076517	APPROVED BY SR	DATE 04/22/15	REMOVE BURRS & BREAK SHARP EDGES: .003/.015 [.076/.381] X 45° CORNER FILLETS: R.02 [.51] MACHINED SURFACES: 200 INCH 5.1 mm SHOWN IN [BRACKETS]
NEW DRAWING <small>COPYRIGHT REGAL BELOIT AMERICA, INC. ALL RIGHTS RESERVED. PROPRIETARY AND CONFIDENTIAL INFORMATION - THIS DOCUMENT IS THE PROPERTY OF REGAL BELOIT AMERICA, INC. (OWNER) AND CONTAINS OWNER'S PROPRIETARY INFORMATION. ANY PERSON, CORPORATION OR OTHER FIRM RECEIVING IT IS DEEMED, BY RECEIVING IT, TO AGREE THAT IT, AND/OR ANY PART OF IT, SHALL NOT BE DISCLOSED TO ANY PERSON, CORPORATION OR OTHER ENTITY, DUPLICATED, AND/OR USED, EXCEPT AS EXPRESSLY APPROVED IN WRITING IN ADVANCE BY OWNER. THIS DOCUMENT SHALL BE RETURNED TO OWNER UPON REQUEST. IT MAY BE SUBJECT TO CERTAIN RESTRICTIONS UNDER APPLICABLE EXPORT CONTROL LAWS AND REGULATIONS.</small>			

DRAWN BY PST	DATE 04/22/15
APPROVED BY SR	DATE 04/22/15
REFERENCE 037724	THIRD ANGLE PROJECTION

912	213/215TC	20.41	8.63	7	5.5	3.5	15.25
DASH	FRAME	C	B	2F	2FF	BS	AG
REGAL ™		Regal Beloit America, Inc.					
DESCRIPTION		OUTLINE					
MATERIAL		210 FR. TENV-8.5" & 4.5" C-FACE					
PROCESS/FINISH		DRAWING NUMBER		SHEET		1 OF 1	
B		037797		1		1	

HIGH VOLTAGE

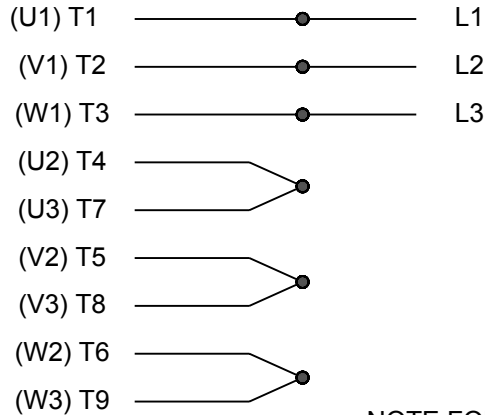

**NOTE FOR FACTORY USE ONLY:
 TO SURGE TEST FOR COMMON CONNECT:
 HIGH VOLT: CONNECT P1 TO T1
 THEN P2 TO L1
 LOW VOLT: CONNECT P1 TO T1 & T7,
 THEN P2 TO L1**

LOW VOLTAGE

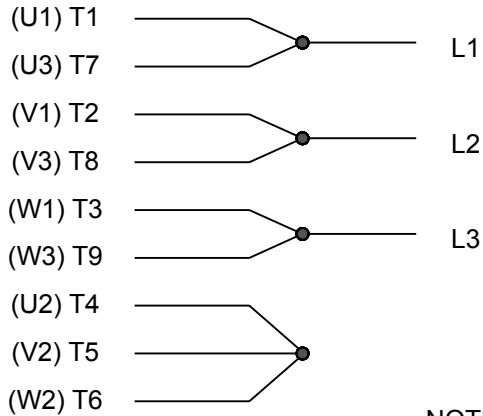

NOTE: LEAD'S COLOR CAN BE YELLOW OR WHITE FOR MT2 PLANT

THREE PHASE DUAL VOLTAGE MOTOR

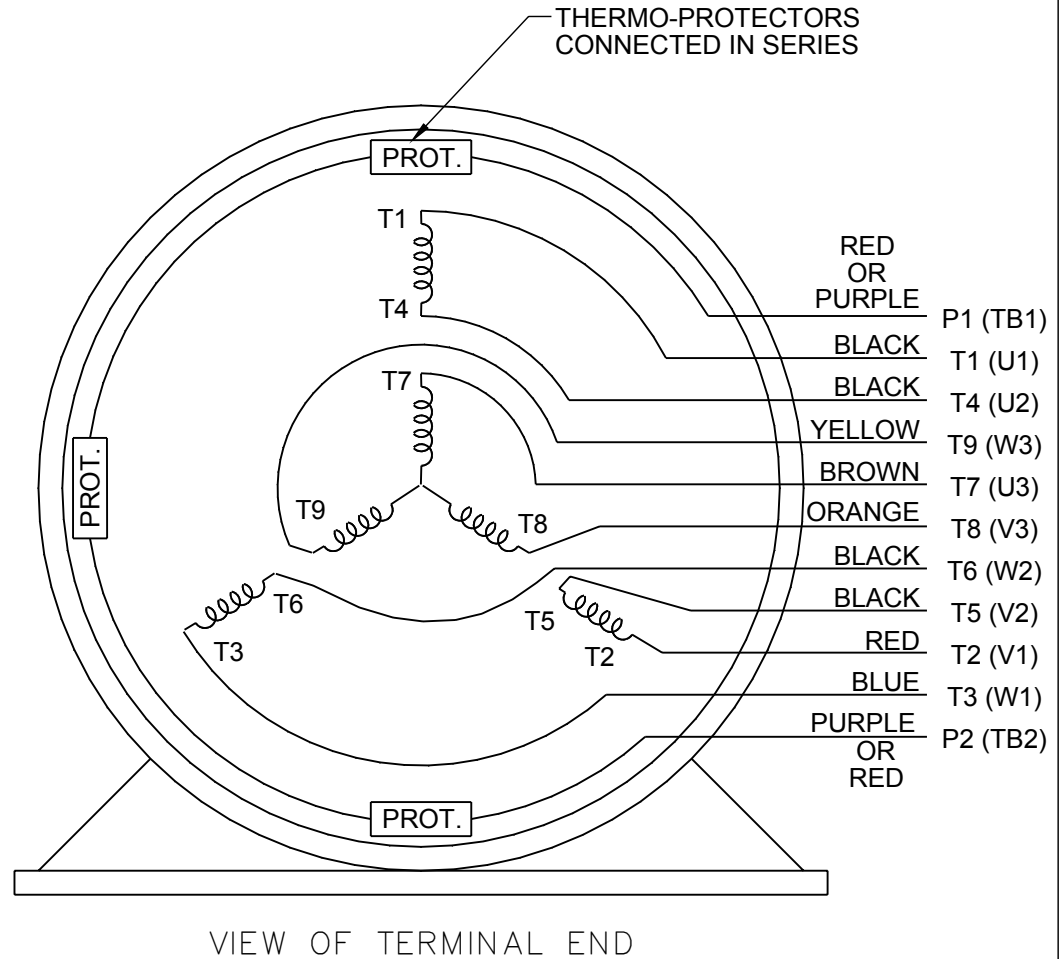

DRAWING REVISION R	REVISION BY AJW	DATE 07-17-2015		DRAWN BY SMC	Regal Beloit America, Inc.
ECO ECO-0081632	APPROVED BY T. VUE	DATE 07-17-2015		DATE 05-13-1992	
ECO DESCRIPTION REV'D IEC NOTATIONS PER IEC 60034-8				APPROVED BY TB	DESCRIPTION CONN DIAGRAM-INTERNAL
<small>COPYRIGHT REGAL BELOIT AMERICA, INC. ALL RIGHTS RESERVED. PROPRIETARY AND CONFIDENTIAL INFORMATION - THIS DOCUMENT IS THE PROPERTY OF REGAL BELOIT AMERICA, INC. ("OWNER") AND CONTAINS OWNER'S PROPRIETARY INFORMATION. ANY PERSON, CORPORATION OR OTHER FIRM RECEIVING IT IS DEEMED, BY RECEIVING IT, TO AGREE THAT IT, AND/OR ANY PART OF IT, SHALL NOT BE DISCLOSED TO ANY PERSON, CORPORATION OR OTHER ENTITY, DUPLICATED, AND/OR USED, EXCEPT AS EXPRESSLY APPROVED IN WRITING IN ADVANCE BY OWNER. THIS DOCUMENT SHALL BE RETURNED TO OWNER UPON REQUEST. IT MAY BE SUBJECT TO CERTAIN RESTRICTIONS UNDER APPLICABLE EXPORT CONTROL LAWS AND REGULATIONS.</small>				DATE 05-13-1992	3 PHASE - DUAL VOLTAGE MOTOR
			REFERENCE EE7308/EE7300	MATERIAL	PROCESS/FINISH
			THIRD ANGLE PROJECTION	SIZE A	DRAWING NUMBER EE7308T

NONE	P/N	NONE	
NONE	NONE		
NONE FT-LB	NONE V	NONE Hz	

DATE: 06/22/2017 07:12:17 AM
FORM 3531 REV.3 02/07/99
** Subject to change without notice.