

# PRODUCT INFORMATION PACKET

Model No: TCA0302AP211GAA009

Catalog No: R446

30.0 kW General Purpose Low Voltage IEC Motor, 3 phase, 1800 RPM, 575 V, 200L Frame, TEFC  
Cast Iron IE3 Efficiency Motors



### Nameplate Specifications

Output HP	<b>40 Hp</b>	Output KW	<b>30.0 kW</b>
Frequency	<b>60 Hz</b>	Voltage	<b>575 V</b>
Current	<b>37.5 A</b>	Speed	<b>1780 rpm</b>
Service Factor	<b>1.15</b>	Phase	<b>3</b>
Efficiency	<b>94.1 %</b>	Power Factor	<b>84</b>
Duty	<b>Continuous</b>	Insulation Class	<b>F</b>
Design Code	<b>N (IEC)</b>	KVA Code	<b>G</b>
Frame	<b>200L</b>	Enclosure	<b>Totally Enclosed Fan Cooled</b>
Thermal Protection	<b>No</b>	Ambient Temperature	<b>40 °C</b>
Drive End Bearing Size	<b>6312</b>	Opp Drive End Bearing Size	<b>6212</b>
UL	<b>Recognized</b>	CSA	<b>N</b>
CE	<b>Y</b>	IP Code	<b>55</b>

### Technical Specifications

Electrical Type	<b>Squirrel Cage Inverter Rated</b>	Starting Method	<b>Line Or Inverter</b>
Poles	<b>4</b>	Rotation	<b>Reversible</b>
Resistance Main	<b>.2 Ohms</b>	Mounting	<b>B3</b>
Motor Orientation	<b>Horizontal</b>	Drive End Bearing	<b>Ball</b>
Opp Drive End Bearing	<b>Ball</b>	Frame Material	<b>Cast Iron</b>
Shaft Type	<b>IEC</b>	Overall Length	<b>30.28 in</b>
Frame Length	<b>14.57 in</b>	Shaft Diameter	<b>2.165 in</b>
Shaft Extension	<b>4.33 in</b>	Assembly/Box Mounting	<b>F3</b>

This is an uncontrolled document once printed or downloaded and is subject to change without notice. Date Created:01/11/2019

# OUTLINE

B

B

A

A

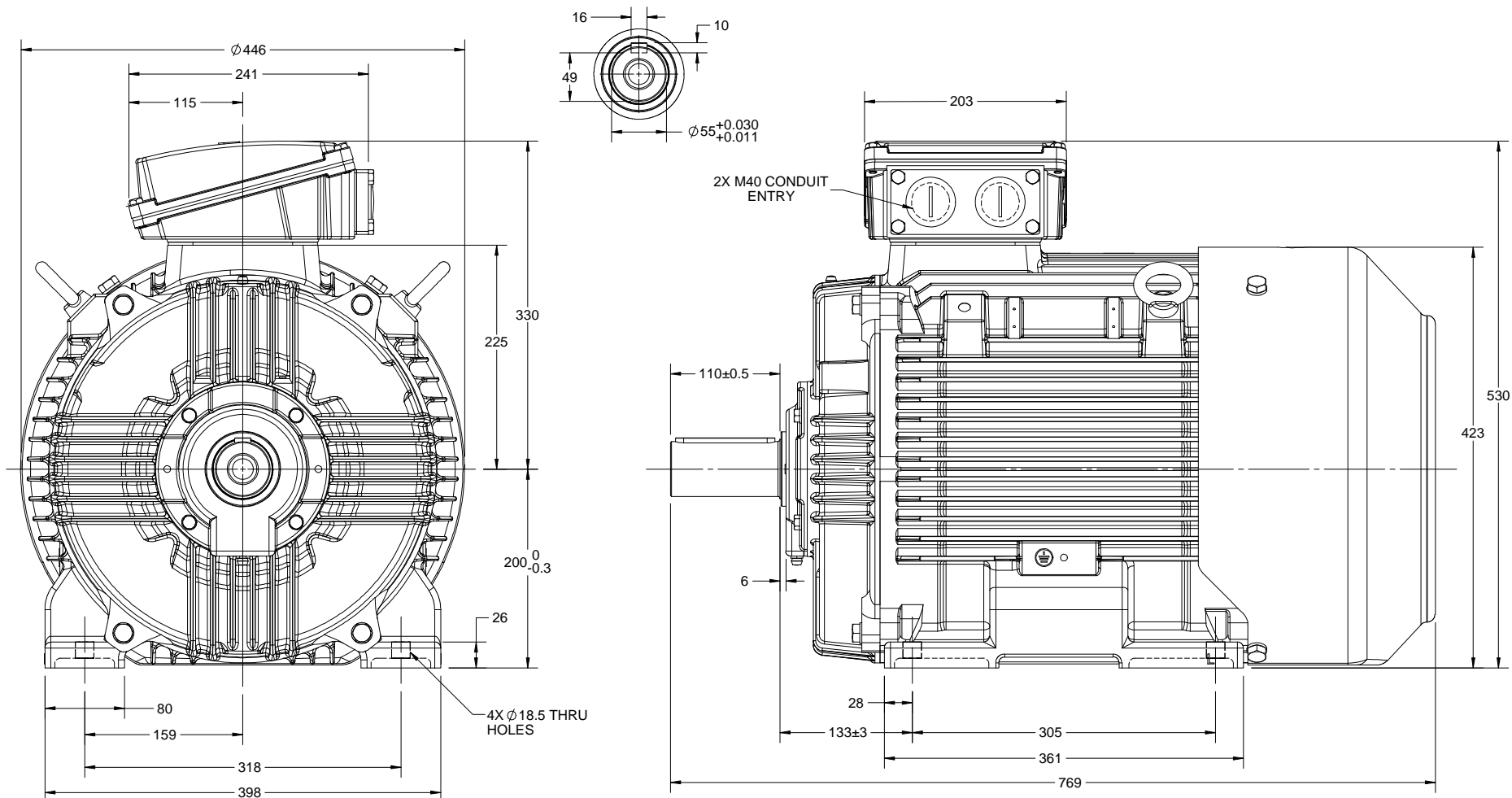

DRAWING REVISION A	REVISION BY LK	DATE 05/12/2018
ECO ECO-0157830	APPROVED BY JAY	DATE 05/12/2018
ECO DESCRIPTION <b>NEW DRAWING RELEASE</b> <small>COPYRIGHT REGAL BELLOTT AMERICA, INC. ALL RIGHTS RESERVED. PROPRIETARY AND CONFIDENTIAL INFORMATION - THIS DOCUMENT IS THE PROPERTY OF REGAL BELLOTT AMERICA, INC. ("OWNER") AND CONTAINS OWNER'S PROPRIETARY INFORMATION. ANY PERSON, CORPORATION OR OTHER FIRM RECEIVING IT IS DEEMED, BY RECEIVING IT, TO AGREE THAT IT, AND/OR ANY PART OF IT, SHALL NOT BE DISCLOSED TO ANY PERSON, CORPORATION OR OTHER ENTITY, DUPLICATED, AND/OR USED, EXCEPT AS EXPRESSLY APPROVED IN WRITING IN ADVANCE BY OWNER. THIS DOCUMENT SHALL BE RETURNED TO OWNER UPON REQUEST. IT MAY BE SUBJECT TO CERTAIN RESTRICTIONS UNDER APPLICABLE EXPORT CONTROL LAWS AND REGULATIONS.</small>		

DRAWN BY LK
DATE 05/12/2018
APPROVED BY JAY
DATE 05/12/2018
REFERENCE

<b>marathon</b> Motors	
DESCRIPTION <b>OUTLINE</b> IEC-200FR-B3 MOTOR TYPE: TEFC-CAST IRON	
MATERIAL	PROCESS/FINISH
SIZE <b>B</b>	DRAWING NUMBER <b>SS312999</b>
THIRD ANGLE PROJECTION	SHEET 1 OF 1

GENERAL TOLERANCE		
LINEAR DIM	>0~6	±0.1
	>6~30	±0.2
	>30~120	±0.3

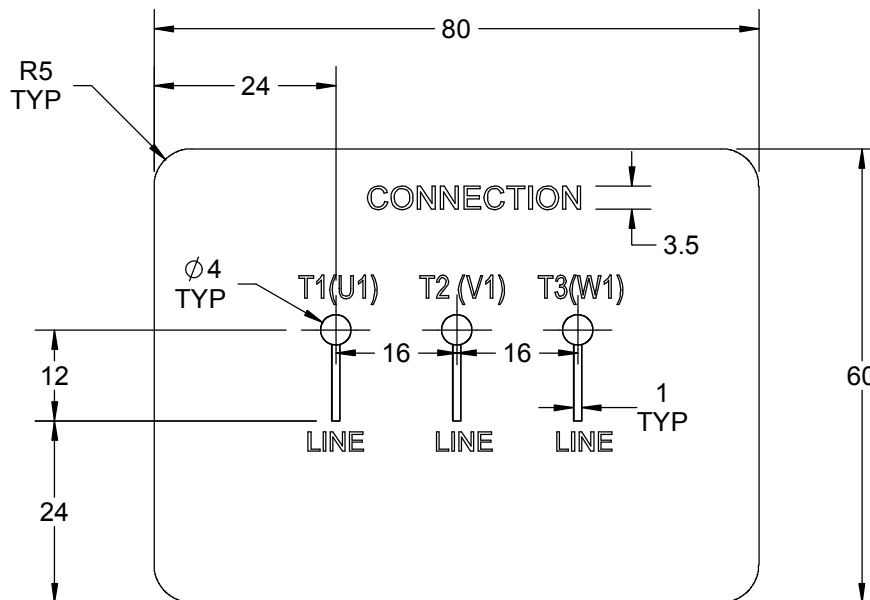

NOTES:

1. PRESSURE-SENSITIVE ADHESIVE TAPE COATED WITH ANTI-ADHESIVE.
2. YELLOW COLOR BACK GROUND LETTERS WILL BE BLACK.
3. THE TOLERANCE OF THE LINEAR SIZE OF THE TOLERANCE WITHOUT THE TOLERANCE BY THE TABLE.
4. LEAD TERMINAL MARKINGS FONT SIZE : T1-T2 - T3 & U1-V1-W1 OF ARIAL WITH 3mm SIZE
5. OTHER LETTER FONT SIZE SHOULD BE 3.5mm.

DRAWING REVISION A	REVISION BY A. KEETHA	DATE 25/07/2019		DRAWN BY A. KEETHA	Regal Beloit America, Inc.		
ECO ECO-0171114	APPROVED BY SN	DATE 25/07/2019		DATE 24/07/2019			
ECO DESCRIPTION NEW DRAWING RELEASE				APPROVED BY SN	DESCRIPTION CONNECTION DIAGRAM 3 LEAD CONNECTION		
<small>COPYRIGHT REGAL BELOIT AMERICA, INC. ALL RIGHTS RESERVED.                  PROPRIETARY AND CONFIDENTIAL INFORMATION - THIS DOCUMENT IS THE PROPERTY OF                  REGAL BELOIT AMERICA, INC. ("OWNER") AND CONTAINS OWNER'S PROPRIETARY                  INFORMATION. ANY PERSON, CORPORATION OR OTHER FIRM RECEIVING IT IS DEEMED,                  BY RECEIVING IT, TO AGREE THAT IT, AND/OR ANY PART OF IT, SHALL NOT BE DISCLOSED                  TO ANY PERSON, CORPORATION OR OTHER ENTITY, DUPLICATED, AND/OR USED, EXCEPT                  AS EXPRESSLY APPROVED IN WRITING IN ADVANCE BY OWNER. THIS DOCUMENT SHALL                  BE RETURNED TO OWNER UPON REQUEST. IT MAY BE SUBJECT TO CERTAIN                  RESTRICTIONS UNDER APPLICABLE EXPORT CONTROL LAWS AND REGULATIONS.</small>				DATE 24/07/2019	MATERIAL	PROCESS/FINISH	
			THIRD ANGLE PROJECTION		SIZE A	DRAWING NUMBER 8442000685	SHEET 1 OF 1