

PRODUCT INFORMATION PACKET

Model No: TCA0111AP211GAA009

Catalog No: R433

11.0 kW General Purpose Low Voltage IEC Motor, 3 phase, 3600 RPM, 575 V, 160M Frame, TEFC
Cast Iron IE3 Efficiency Motors





Nameplate Specifications

Output HP	15 Hp	Output KW	11.0 kW
Frequency	60 Hz	Voltage	575 V
Current	13.5 A	Speed	3550 rpm
Service Factor	1.15	Phase	3
Efficiency	91 %	Power Factor	90
Duty	Continuous	Insulation Class	F
Design Code	N (IEC)	KVA Code	G
Frame	160M	Enclosure	Totally Enclosed Fan Cooled
Thermal Protection	No	Ambient Temperature	40 °C
Drive End Bearing Size	6309	Opp Drive End Bearing Size	6209
UL	Recognized	CSA	N
CE	Y	IP Code	55

Technical Specifications

Electrical Type	Squirrel Cage Inverter Rated	Starting Method	Line Or Inverter
Poles	2	Rotation	Reversible
Resistance Main	.93 Ohms	Mounting	B3
Motor Orientation	Horizontal	Drive End Bearing	Ball
Opp Drive End Bearing	Ball	Frame Material	Cast Iron
Shaft Type	IEC	Overall Length	24.49 in
Frame Length	10.00 in	Shaft Diameter	1.654 in
Shaft Extension	4.33 in	Assembly/Box Mounting	F3

This is an uncontrolled document once printed or downloaded and is subject to change without notice. Date Created:01/11/2019

4

3

Uncontrolled Copy

2

1

B

B

A

A

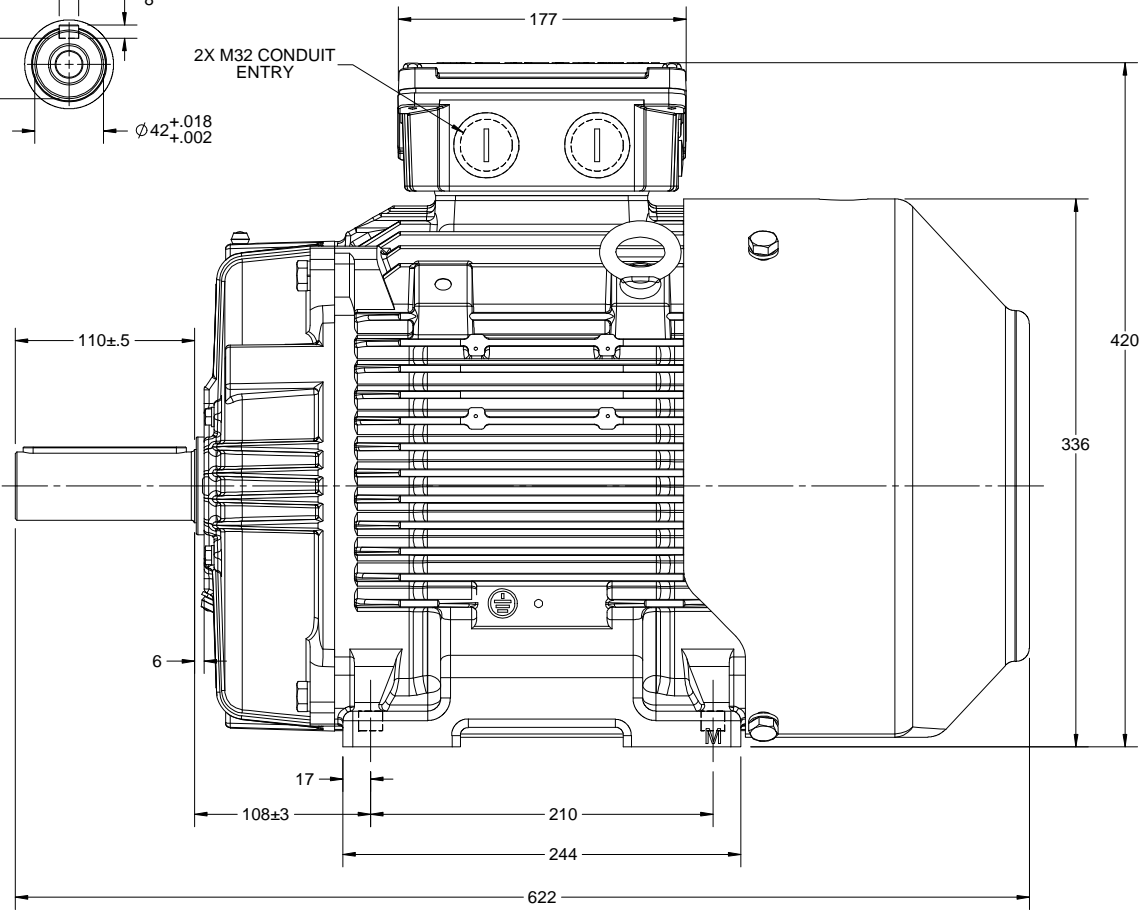
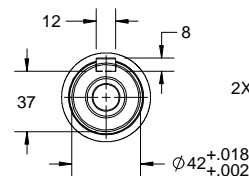
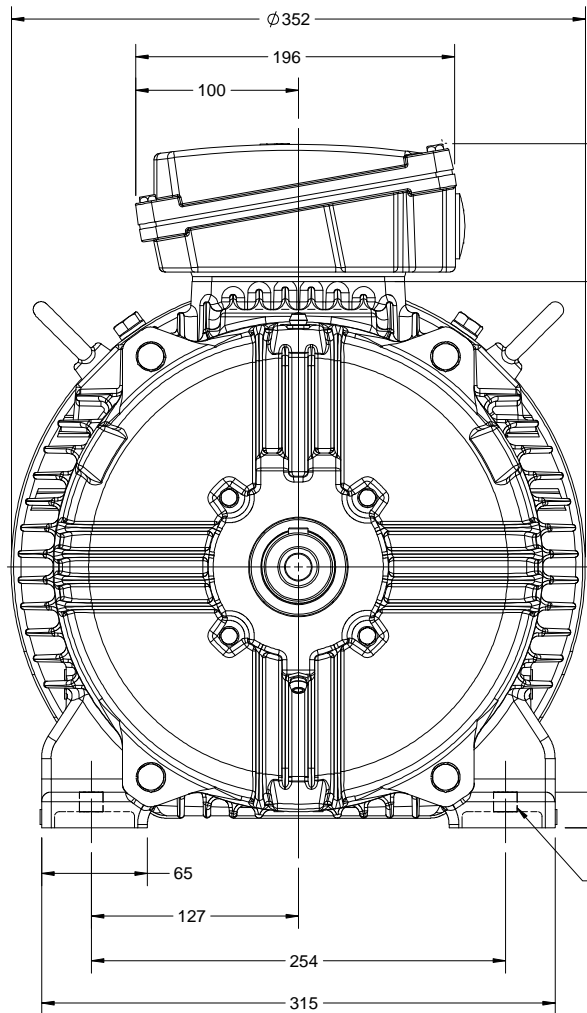

DRAWING REVISION A	REVISION BY LK	DATE 05/12/2018
ECO ECO-0157830	APPROVED BY JAY	DATE 05/12/2018
ECO DESCRIPTION NEW DRAWING RELEASE		
<small>COPYRIGHT REGAL BELLOTT AMERICA, INC. ALL RIGHTS RESERVED. PROPRIETARY AND CONFIDENTIAL INFORMATION - THIS DOCUMENT IS THE PROPERTY OF REGAL BELLOTT AMERICA, INC. ("OWNER") AND CONTAINS OWNER'S PROPRIETARY INFORMATION. ANY PERSON, CORPORATION OR OTHER FIRM RECEIVING IT IS DEEMED, BY RECEIVING IT, TO AGREE THAT IT, AND/OR ANY PART OF IT, SHALL NOT BE DISCLOSED TO ANY PERSON, CORPORATION OR OTHER ENTITY, DUPLICATED, AND/OR USED, EXCEPT AS EXPRESSLY APPROVED IN WRITING IN ADVANCE BY OWNER. THIS DOCUMENT SHALL BE RETURNED TO OWNER UPON REQUEST. IT MAY BE SUBJECT TO CERTAIN RESTRICTIONS UNDER APPLICABLE EXPORT CONTROL LAWS AND REGULATIONS.</small>		

DRAWN BY LK	marathon Motors
DATE 05/12/2018	
APPROVED BY JAY	DESCRIPTION OUTLINE IEC-160M-B3-MTG MOTOR TYPE : TEFC-CAST IRON
DATE 05/12/2018	MATERIAL PROCESS/FINISH
REFERENCE	SIZE B
THIRD ANGLE PROJECTION	DRAWING NUMBER SS208563
	SHEET 1 OF 1

4

3

2

1

GENERAL TOLERANCE		
LINEAR DIM	>0~6	±0.1
	>6~30	±0.2
	>30~120	±0.3

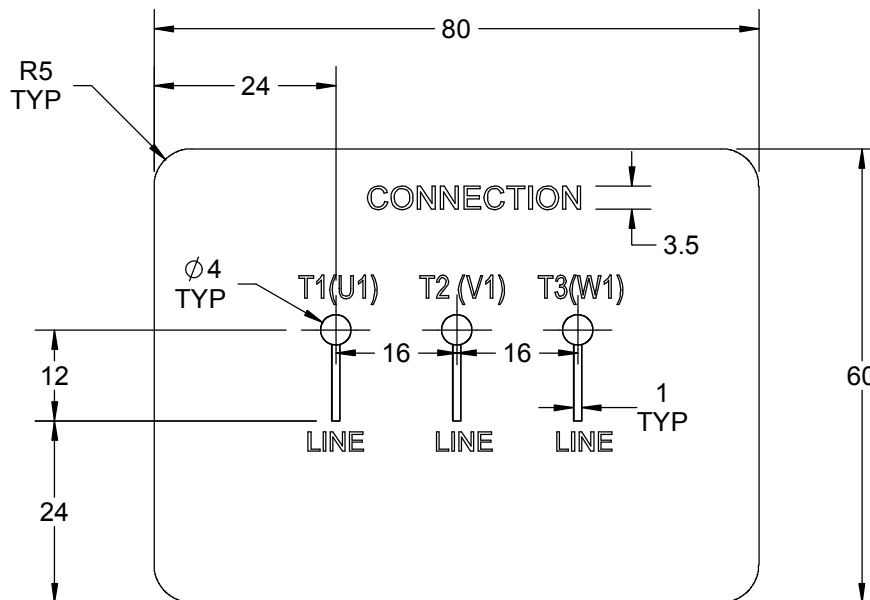

NOTES:

1. PRESSURE-SENSITIVE ADHESIVE TAPE COATED WITH ANTI-ADHESIVE.
2. YELLOW COLOR BACK GROUND LETTERS WILL BE BLACK.
3. THE TOLERANCE OF THE LINEAR SIZE OF THE TOLERANCE WITHOUT THE TOLERANCE BY THE TABLE.
4. LEAD TERMINAL MARKINGS FONT SIZE : T1-T2 - T3 & U1-V1-W1 OF ARIAL WITH 3mm SIZE
5. OTHER LETTER FONT SIZE SHOULD BE 3.5mm.

DRAWING REVISION A	REVISION BY A. KEETHA	DATE 25/07/2019		DRAWN BY A. KEETHA	Regal Beloit America, Inc.
ECO ECO-0171114	APPROVED BY SN	DATE 25/07/2019		DATE 24/07/2019	
ECO DESCRIPTION NEW DRAWING RELEASE				APPROVED BY SN	DESCRIPTION CONNECTION DIAGRAM 3 LEAD CONNECTION
COPYRIGHT REGAL BELOIT AMERICA, INC. ALL RIGHTS RESERVED. PROPRIETARY AND CONFIDENTIAL INFORMATION - THIS DOCUMENT IS THE PROPERTY OF REGAL BELOIT AMERICA, INC. ("OWNER") AND CONTAINS OWNER'S PROPRIETARY INFORMATION. ANY PERSON, CORPORATION OR OTHER FIRM RECEIVING IT IS DEEMED, BY RECEIVING IT, TO AGREE THAT IT, AND/OR ANY PART OF IT, SHALL NOT BE DISCLOSED TO ANY PERSON, CORPORATION OR OTHER ENTITY, DUPLICATED, AND/OR USED, EXCEPT AS EXPRESSLY APPROVED IN WRITING IN ADVANCE BY OWNER. THIS DOCUMENT SHALL BE RETURNED TO OWNER UPON REQUEST. IT MAY BE SUBJECT TO CERTAIN RESTRICTIONS UNDER APPLICABLE EXPORT CONTROL LAWS AND REGULATIONS.				DATE 24/07/2019	MATERIAL
			THIRD ANGLE PROJECTION		SIZE A

P.O. BOX 8003
WAUSAU, WI 54401-8003
PH. 715-675-3311

DATA VOLTS: 460

CERTIFICATION DATA SHEET

CUSTOMER: _____
ORDER #: _____
CONN. DIAGRAM: 8442000677
OUTLINE: SS208563
WINDING: IE3L1602201
SPEED: _____

CUSTOMER P.O. #: _____
REFERENCE MODEL #: TCA0111AP21TGA009
CAT #: R433
CUSTOMER PART #: _____
MOUNTING: F3

TYPICAL MOTOR PERFORMANCE DATA

HP	KW	SYNC RPM	FL RPM	FRAME	ENCLOSURE	TYPE	KVA CODE	DESIGN	
15	11.2	3600	3550	160M	TEFC	TCA160MB02	G	N	
PH	HZ	VOLTS	AMPS	START TYPE	DUTY	INSL	S.F.	AMB	ELEV.
3	60	575	13.5	LINE OR INVERTER	CONT	F	1.15	40	3300
F.L. EFF		91.0	3/4 LD EFF	91.0	1/2 LD EFF	90.3	GTD EFF	ELECT. TYPE	
F.L. PF		90.0	3/4 LD PF	86.0	1/2 LD PF	79.0	89.7	SQ CAGE INV RATED	
F.L. TORQUE		LR AMPS @ 460 V		L.R. TORQUE		B.D. TORQUE		F.L. RISE (°C)	
22.2	LB-FT	94.6	37.6	LB-FT	169%	64.0	LB-FT	288%	80
@ 3 FT.		POWER	ROTOR WK²	MAX. LOAD WK²	SAFE STALL TIME	START/HOUR	MOTOR WGT		
75	DBA	84	1.49	LB-FT²	1.49	LB-FT²	10	SEC.	2
141	LB.								

***** SUPPLEMENTAL INFORMATION *****

DE BRACKET TYPE	ODE BRACKET TYPE	MOUNT TYPE	MOTOR ORIENTATION	SEVERE DUTY	HAZARDOUS LOCATION	DRIP COVER	SCREENS	PAINT
STANDARD	STANDARD	B3	HORIZONTAL	NO	NONE	NO	NONE	BLUE - RAL 5014
BEARINGS	GREASE	SHAFT TYPE	SPECIAL DE	SPECIAL ODE	SHAFT MATERIAL	FRAME MATERIAL		
DE ODE BALL 6309	POLYREX EM	STANDARD IEC	NONE	NONE	1045 HOT ROLLED (C-204)	CAST IRON		

THERMOSTATS	PROTECTORS	WDG RTD's	BRG RTD's	THERMISTORS	CONTROL	SPACE HEATERS
NONE	NOT	NONE	NONE	NONE	FALSE	NA
R1 (ohms/ph)	R2 (ohms/ph)	X1 (ohms/ph)	X2 (ohms/ph)	Xm (ohms/ph)	VIBRATION (in/sec)	FLOAT ODE
0.886	0.355	1.921	1.714	74.99	0.090	ODE

* N O T E S *	INVERTER TORQUE: CONSTANT 2:1/VARIABLE 10:1	
	INV. HP SPEED RANGE: NONE	
	ENCODER: NONE	NONE PPR
	BRAKE: NONE	NONE
	FT-LB: NONE	NA
	VOLTAGE: NONE	NONE

PREPARED BY: Fareeda Dudekula
DATE: 5/29/2019
UL: V - LIME-INS CONST UL REC



Data Sheet

TCA0114P211GAA009

Date: 5/29/2019

Customer: _____
Attention: _____

Submital

Submitted by: Fareeda Dudekula

Data @ 575 V

Load	Motor Load Data							LR
	0%	25%	50%	75%	100%	115%	125%	
Current (Amps)	4.3	5.7	7.8	10.7	13.5	15.8	17.1	94.6
Torque (ft-lb)	0.00	5.5	11.0	16.6	22.2	25.6	27.9	37.6
RPM	3600	3588	3576	3563	3550	3541	3535	0
Efficiency (%)		85.4	90.3	91.0	91.0	90.4	90.0	
P.F. (%)	10.0	58.0	79.0	86.0	90.0	91.0	91.0	63.4

Motor Speed Data

	LR	Pull-Up	BD	Rated	Idle
Speed (RPM)	0	1200	3259	3550	3600
Current (Amps)	94.6	89.8	57.4	13.5	4.3
Torque (ft-lb)	37.6	35.7	64.0	22.2	0.00

IEC

Information Block				
HP	15.0			
Sync. RPM	3600			
Frame	160			
Enclosure	TEFC			
Construction	TCA 160MB02			
Voltage	575 V			
Frequency	60 Hz			
Design	N			
LR Code letter	G			
Service Factor	1.15			
Temp Rise @ FL	80 °C			
Duty	CONT			
Ambient	40 °C			
Elevation	3,300 feet			
Rotor/Shaft wk ²	1.49 Lb-Ft ²			
Ref Wdg	IE3L1602201 NONE			
Sound Pressure @ 1M	75 dBA			
VFD Rating	CONSTANT 2:1/VARIABLE 10:1			
Outline Dwg	SS2008563			
Conn. Diag	8442000677			
Additional Specifications:				
0				
EQUIV CKT (OHMS / PHASE)				
R1	R2	X1	X2	Xm
0.8860	0.3590	1.9210	1.7140	74.9900

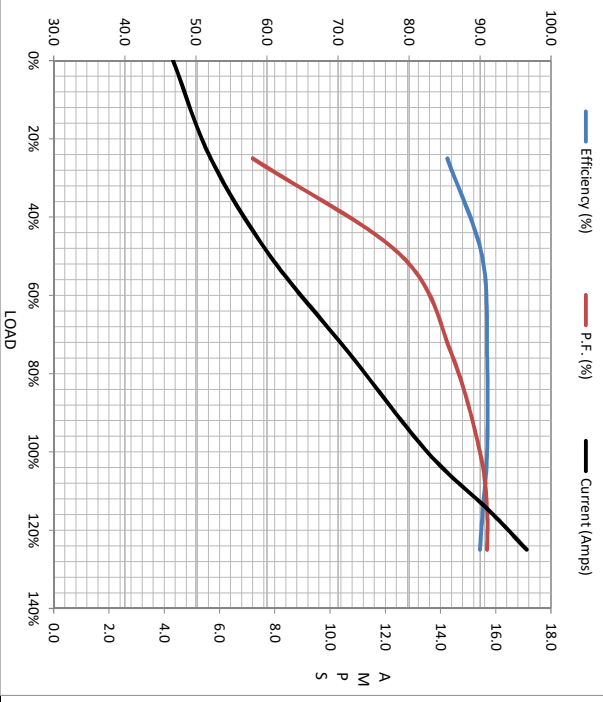

Speed - Torque Curve

