

# PRODUCT INFORMATION PACKET

**marathon**<sup>®</sup>  
Motors

Model No: 326TTFS16102  
Catalog No: L417B  
25,900, TEFC, 326T, 3/60/230/460  
Totally Enclosed Fan Cooled (TEFC)



Regal and Marathon are trademarks of Regal Beloit Corporation or one of its affiliated companies.  
©2018 Regal Beloit Corporation, All Rights Reserved. MC017097E

**REGAL**<sup>®</sup>



### Nameplate Specifications

Output HP	<b>25 Hp</b>	Output KW	<b>18.7 kW</b>
Frequency	<b>60 Hz</b>	Voltage	<b>230/460 V</b>
Current	<b>73.0/36.5 A</b>	Speed	<b>882 rpm</b>
Service Factor	<b>1.15</b>	Phase	<b>3</b>
Efficiency	<b>90.2 %</b>	Duty	<b>Continuous</b>
Insulation Class	<b>F</b>	Design Code	<b>B</b>
KVA Code	<b>G</b>	Frame	<b>326T</b>
Enclosure	<b>Totally Enclosed Fan Cooled</b>	Overload Protector	<b>No</b>
Ambient Temperature	<b>40 °C</b>	Drive End Bearing Size	<b>6312</b>
Opp Drive End Bearing Size	<b>6311</b>	UL	<b>Recognized</b>
CSA	<b>Y</b>	CE	<b>Y</b>
IP Code	<b>43</b>		

### Technical Specifications

Electrical Type	<b>Squirrel Cage Induction Run</b>	Starting Method	<b>Across The Line</b>
Poles	<b>8</b>	Rotation	<b>Reversible</b>
Mounting	<b>Rigid base</b>	Motor Orientation	<b>HORIZONTAL</b>
Drive End Bearing	<b>BALL</b>	Opp Drive End Bearing	<b>BALL</b>
Frame Material	<b>Cast Iron</b>	Shaft Type	<b>T</b>
Overall Length	<b>30.37 in</b>	Frame Length	<b>13.00 in</b>
Shaft Diameter	<b>2.125 in</b>	Shaft Extension	<b>5.25 in</b>
Assembly/Box Mounting	<b>F1/F2 CAPABLE</b>		
Outline Drawing	<b>B-SS28289-1300</b>	Connection Diagram	<b>A-EE7308</b>

This is an uncontrolled document once printed or downloaded and is subject to change without notice. Date Created: 10/30/2018

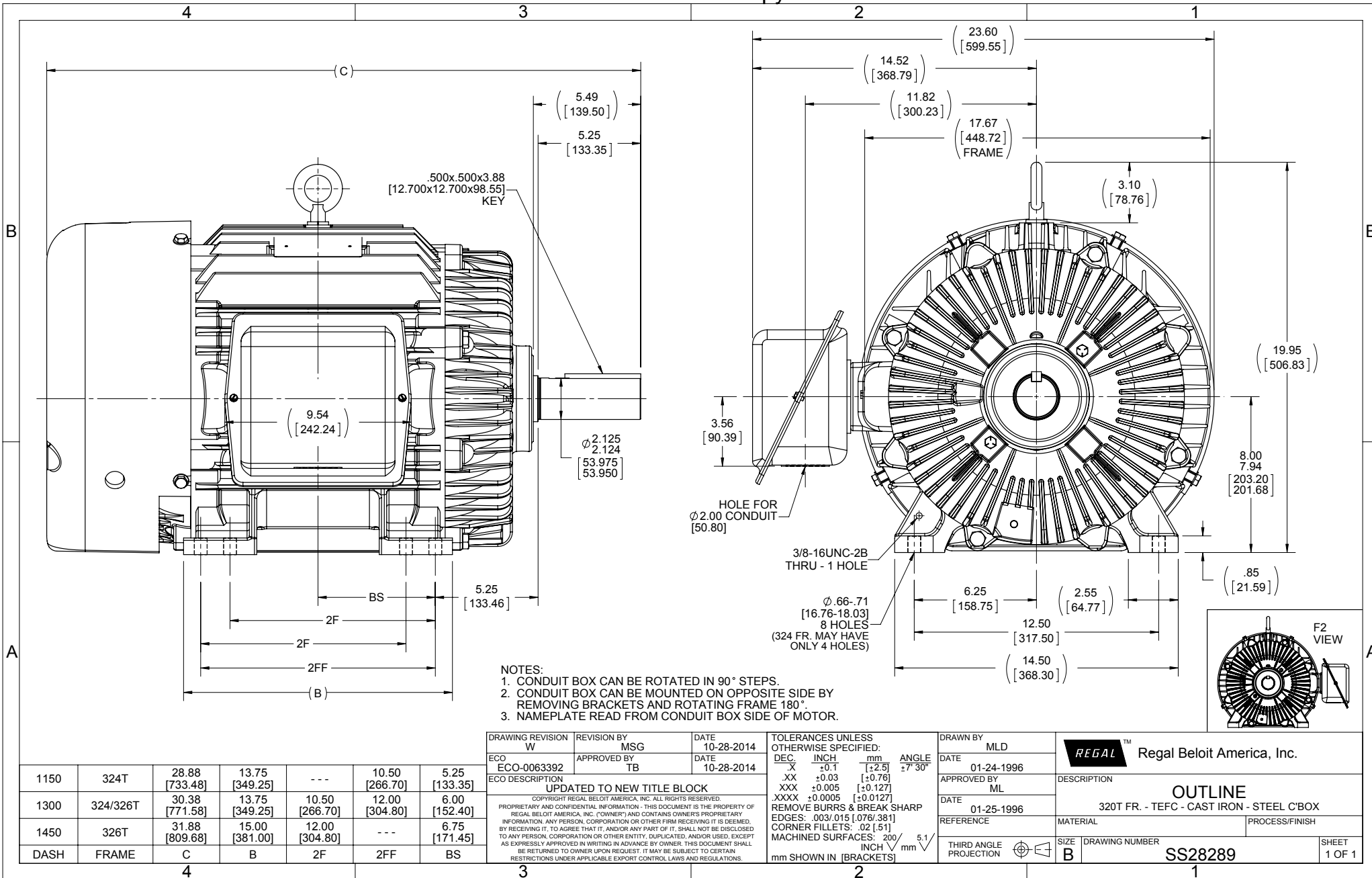

EE7308

THREE PHASE  
DUAL VOLTAGE MOTOR



VIEW OF TERMINAL END

REF.  
WINDING DIAGRAM

T8Y, T2Y, T2BL, T4BX, T2EC, T2G  
T6BZ, T2B, T6BL, T4AV, T6B, T4B

OPTIONAL CORD  
CONNECTION

L1 — WHITE  
L2 — RED  
L3 — BLACK

NO.	REVISION	BY & DATE	CHK	ANG	TOLERANCES UNLESS SPECIFIED		FINISH	DRAWN RM 11/20/1990				
					DEC.	INCHES						
5	CHG TO REGAL LOGO	SL 09/10/2015	AB					CHK ML 11/21/1990				
4	REVISED IEC NOTATIONS	MSG 11/15/2011	CMN	.X	±.1			APPD SAS 04/24/2003				
3	ADDED IEC NOTATIONS... (U1), (V1) ETC. MU95194	MSG 5/10/2010	MJS	.XX	±.02		TITLE CONNECTION DIAGRAM	SCALE 1=1				
2	ADDED THE OPTIONAL CORD CONNECTION MU46318	RDH 04/24/2003	DRS	.XXX	±.005		3Ø - DUAL VOLTAGE MOTOR	REF				
1	REDRAWN	RM 11/20/1990		.XXXX	±.0005		MAT'L.	FMF				
					±7'30"			PREV				
THIS DRAWING IN DESIGN AND DETAIL IS OUR PROPERTY AND MUST NOT BE USED EXCEPT IN CONNECTION WITH OUR WORK ALL RIGHTS OF DESIGN AND INVENTION ARE RESERVED THIS IS AN ELECTRONICALLY GENERATED DOCUMENT - DO NOT SCALE THIS PRINT							RFP	CAD FILE ee7308	SIZE A	DRAWING NO. EE7308	PAGE OF 5	REV. 5
							DIST WP					



Regal Beloit America, Inc.

3Ø - DUAL VOLTAGE MOTOR



P.O. BOX 8003  
WAUSAU, WI 54401-8003  
PH. 715-675-3311

DATA VOLTS: 460

CERTIFICATION DATA SHEET

CUSTOMER P.O. #:   
 ORDER #: A-EE7308  
 REFERENCE MODEL #: 326TTS16102  
 CONN. DIAGRAM: B-SS28289-1300  
 CAT #: L417B  
 WINDING: 326836 NONE 3  
 CUSTOMER PART #:   
 MOUNTING: F1/F2 CAPABLE  
 SPEED:   
 TYPICAL MOTOR PERFORMANCE DATA

HP	KW	SYNC RPM	FL RPM	FRAME	ENCLOSURE	TYPE	KVA CODE	DESIGN
25	18.7	900	882	328T	TEFC	TEN	G	B

PH	HZ	VOLTS	AMPS	START TYPE	DUTY	INSL	S.F.	AMB	ELEV.
3	60/50	230/460#190/380	73/36.5#73/36.5	ACROSS-THE LINE	CONT	F	1.15	40	3300
	F.L. EFF	90.2	3/4 LD EFF	90.2	1/2 LD EFF	88.5	GTD EFF		ELECT. TYPE
	F.L. PF	70.0	3/4 LD PF	63.0	1/2 LD PF	51.0	89.5		SQ CAGE IND RUN
F.L. TORQUE	LR AMPS @ 460 V	L.R. TORQUE	B.D. TORQUE	F.L. RISE (°C)					
149 LB-FT	182	245 LB-FT	164%	340 LB-FT	228%	60			
@ 3 FT.	POWER	ROTOR WK <sup>2</sup>	MAX. LOAD WK <sup>2</sup>	SAFE STALL TIME	START/SHOUR	MOTOR WGT			
62 DBA	71 DBA	10.2 LB-FT <sup>2</sup>	0 LB-FT <sup>2</sup>	20 SEC.	0	800 LB.			

\*\*\* SUPPLEMENTAL INFORMATION \*\*\*

DE BRACKET TYPE	ODE BRACKET TYPE	MOUNT TYPE	MOTOR ORIENTATION	SEVERE DUTY	HAZARDOUS LOCATION	DRIP COVER	SCREENS	PAINT
STANDARD	STANDARD	RIGID	HORIZONTAL	NO	NONE	NO	NONE	BLUE (ENAMEL)
BEARINGS	GREASE	SHAFT TYPE	SPECIAL DE	SPECIAL ODE	SHAFT	MATERIAL	FRAME MATERIAL	
BALL BALL 6312 6311	POLYREX EM	T	NONE	NONE	1045 HOT ROLLED (C-204)		CAST IRON	
THERMOSTATS	PROTECTORS	WDG RTD's	BRG RTD's	THERMISTORS	CONTROL	SPACE HEATERS		
NONE	NOT	NONE	NONE	NONE	FALSE	NA		
R1 (ohms/ph)	R2 (ohms/ph)	X1 (ohms/ph)	X2 (ohms/ph)	Xm (ohms/ph)	VIBRATION (in/sec)	FLOAT		
0.192	0.158	1.017	0.836	11.583	0.150	ODE		

N	INVERTER TORQUE: NONE
O	INV. HP SPEED RANGE: NONE
T	
E	ENCODER: NONE
S	NONE
	BRAKE: NONE
	FT-LB: NONE
	VOLTAGE: NONE
	UL: V/INS, CONST UL REC

PREPARED BY: FAREEDA DUDEKULA  
 DATE: 9/11/2018  
 FORM: 3531 REV 4 2/27/06

