

PRODUCT INFORMATION PACKET

marathon[®]
Motors

Model No: 213TTFBD6085
Catalog No: GT3411A
3,1200,TEFC,213JP,3/60/230/460
JP



Regal and Marathon are trademarks of Regal Beloit Corporation or one of its affiliated companies.
©2018 Regal Beloit Corporation, All Rights Reserved. MC017097E

REGAL[®]



Nameplate Specifications

Output HP	3 Hp	Output KW	2.2 kW
Frequency	60 Hz	Voltage	230/460 V
Current	8.6/4.3 A	Speed	1185 rpm
Service Factor	1.15	Phase	3
Efficiency	89.5 %	Duty	Continuous
Insulation Class	F	Design Code	B
KVA Code	J	Frame	213JPV
Enclosure	Totally Enclosed Fan Cooled	Overload Protector	No
Ambient Temperature	40 °C	Drive End Bearing Size	6309
Opp Drive End Bearing Size	6206	UL	Recognized
CSA	Y	CE	Y
IP Code	43		

Technical Specifications

Electrical Type	Squirrel Cage Inverter Rated	Starting Method	Line Or Inverter
Poles	6	Rotation	Reversible
Mounting	Rigid base	Motor Orientation	Horizontal Or Shaft Down
Drive End Bearing	Ball	Opp Drive End Bearing	Ball
Frame Material	Rolled Steel	Shaft Type	JP
Frame Length	9.65 in	Shaft Diameter	1.25 in
Shaft Extension	8.39 in	Assembly/Box Mounting	F1/F2 Capable
Outline Drawing	SS620827	Connection Diagram	EE7308

This is an uncontrolled document once printed or downloaded and is subject to change without notice. Date Created: 07/02/2018

SS620827

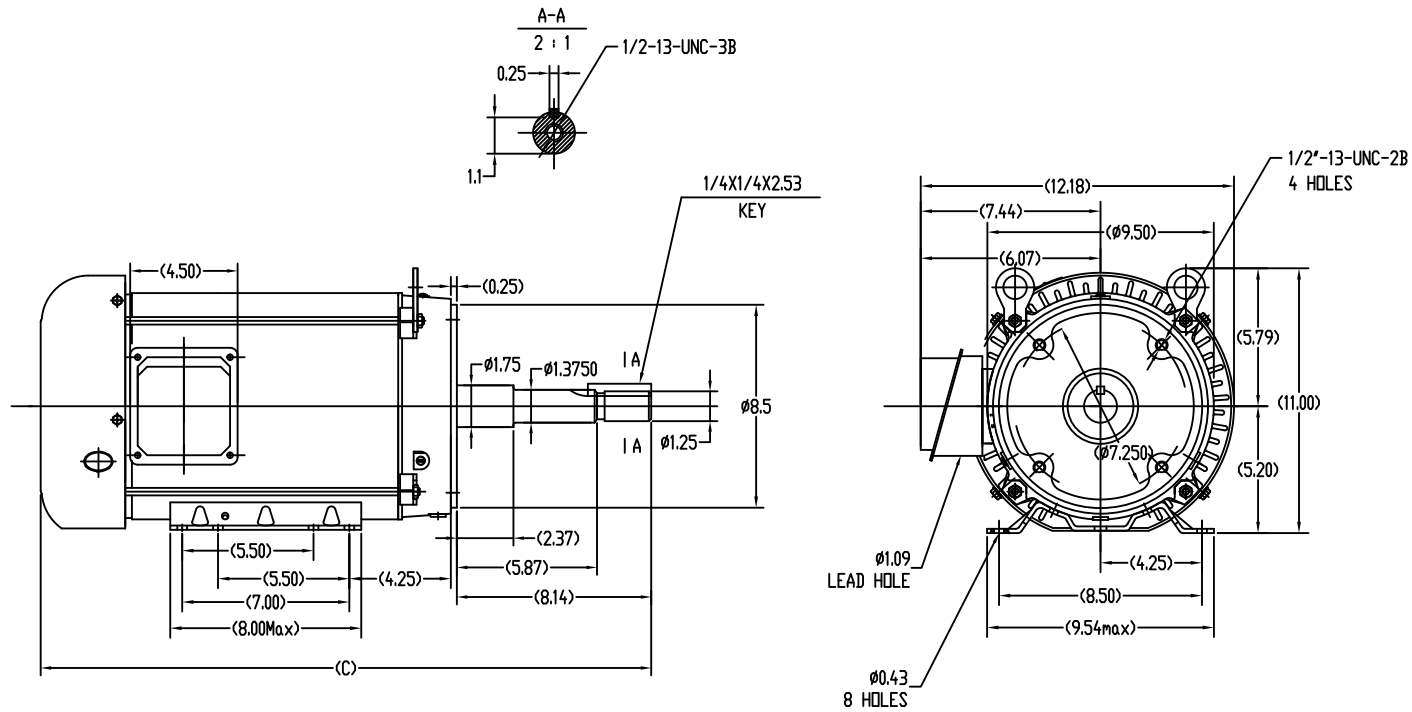

213TC	24.01
215TC	25.78
FRAME	C

		TOLERANCES UNLESS SPECIFIED		DRAWN ZYH 4/13/2017	
		DEC.	INCHES	CHK	
		.X	±.1	APPD	
		.XX	±.03	SCALE 1=4	
		.XXX	±.005	REF	
1	UPDATED KEY DETAILS	XIADWEI ZHU	29/05/2017	YZ	300X ±.005
NO.	REVISION	BY & DATE	CHK	ANG	±1/2
				RFP	FINISH
				CAD FILE	SS620827
				SIZE	DRAWING NO.
				B	SS620827
				REV.	B
<p>THIS DRAWING IN DESIGN AND DETAIL IS OUR PROPERTY AND MUST NOT BE USED EXCEPT IN CONNECTION WITH OUR WORK. ALL RIGHTS OF DESIGN AND INVENTION ARE RESERVED. THIS IS AN ELECTRONICALLY GENERATED DOCUMENT - DO NOT SCALE THIS PRINT</p>					

EE7308

THREE PHASE
DUAL VOLTAGE MOTOR



VIEW OF TERMINAL END

REF.
WINDING DIAGRAM

T8Y, T2Y, T2BL, T4BX, T2EC, T2G
T6BZ, T2B, T6BL, T4AV, T6B, T4B

OPTIONAL CORD
CONNECTION

L1 — WHITE
L2 — RED
L3 — BLACK

NO.	REVISION	BY & DATE	CHK	ANG	TOLERANCES UNLESS SPECIFIED		FINISH	DRAWN RM 11/20/1990				
					DEC.	INCHES						
5	CHG TO REGAL LOGO	SL 09/10/2015	AB					CHK ML 11/21/1990				
4	REVISED IEC NOTATIONS	MSG 11/15/2011	CMN	.X	±.1			APPD SAS 04/24/2003				
3	ADDED IEC NOTATIONS... (U1), (V1) ETC. MU95194	MSG 5/10/2010	MJS	.XX	±.02			SCALE 1=1				
2	ADDED THE OPTIONAL CORD CONNECTION MU46318	RDH 04/24/2003	DRS	.XXX	±.005		TITLE CONNECTION DIAGRAM 3Ø - DUAL VOLTAGE MOTOR	REF				
1	REDRAWN	RM 11/20/1990		.XXXX	±.0005		MAT'L.	FMF				
					±7'30"			PREV				
THIS DRAWING IN DESIGN AND DETAIL IS OUR PROPERTY AND MUST NOT BE USED EXCEPT IN CONNECTION WITH OUR WORK ALL RIGHTS OF DESIGN AND INVENTION ARE RESERVED THIS IS AN ELECTRONICALLY GENERATED DOCUMENT - DO NOT SCALE THIS PRINT							RFP	CAD FILE ee7308	SIZE A	DRAWING NO. EE7308	PAGE OF 5	REV. 5
							DIST WP					

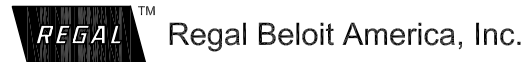



**P.O. BOX 8003
WAUSAU, WI 54401-8003
PH. 715-675-3311**

CERTIFICATION DATA SHEET

CUSTOMER: CUSTOMER
ORDER #: PO #:
CONN. DIAGRAM: EE7308 MODEL #: 213TTFBD6085 AA
OUTLINE: SS620827 CUSTOMER PART #:
WINDING #: HE31326018 2 MOUNTING: F1/F2 CAPABLE

TYPICAL MOTOR PERFORMANCE DATA

HP	KW	SYNC. RPM	F.L. RPM	FRAME	ENCLOSURE	KVA CODE	DESIGN	
3&2	2.24&1.49	1200	1185&987	213JPV	TEFC	J	B	
PH	Hz	VOLTS	AMPS	START TYPE	DUTY	INSL	S.F.	AMB°C
3	60/50	230/460&190/380	8.6/4.3&7.4/3.7	LINE OR INVERTER	CONTINUOUS	F7	1.15/1.15	40

FULL LOAD EFF:	89.5&89	3/4 LOAD EFF:	89	1/2 LOAD EFF:	87.3	GTD. EFF	88.5	ELEC. TYPE
FULL LOAD PF:	73&68.5	3/4 LOAD PF:	66.2	1/2 LOAD PF:	54.4	SQ CAGE INV RATED		

F.L. TORQUE	LOCKED ROTOR AMPS	L.R. TORQUE	B.D. TORQUE	F.L. RISE°C
13.3 LB-FT	70 / 35	28 LB-FT	37 LB-FT	278 %
				50

SOUND PRESSURE @ 3 FT.	SOUND POWER	ROTOR WK^2	MAX. WK^2	SAFE STALL TIME	STARTS / HOUR	APPROX. MOTOR WGT
55 DBA	65 DBA	1 LB-FT^2	90 LB-FT^2	25 SEC.	2	200 LBS.

***** SUPPLEMENTAL INFORMATION *****

DE BRACKET TYPE	ODE BRACKET TYPE	MOUNT TYPE	ORIENTATION	SEVERE DUTY	HAZARDOUS LOCATION	DRIP COVER	SCREENS	PAINT
C-FACE	STANDARD	RIGID	HORIZONTAL OR SHAFT DOWN	FALSE	NONE	FALSE	NONE	BLUE (ENAMEL)

BEARINGS		GREASE	SHAFT TYPE	SPECIAL DE	SPECIAL ODE	SHAFT MATERIAL	FRAME MATERIAL
DE	ODE						
BALL	BALL	POLYREX EM	JP	NONE	NONE	1045 HOT ROLLED (C-204)	ROLLED STEEL
6309	6206						

THERMO-PROTECTORS				THERMISTORS	CONTROL	SPACE HEATERS
THERMOSTATS	PROTECTORS	WDG RTDS	BRG RTDS	NONE	FALSE	NONE
NONE	NOT	NONE	NONE			

INVERTER

TORQUE: CONSTANT 20:1/VARIABLE 20:1

INV. HP SPEED RANGE: NONE

ENCODER:	NONE
	NONE
	PPR

BRAKE:	NONE	NONE
	NONE	P/N NONE
	NONE	NONE
	FT-LB	NONE V NONE HZ

*
N
O
T
E
S

*

PREPARED BY: Fareeda Dudekula

DATE: 05/04/2018 09:08:14 AM

FORM: 3531 REV.3 02/07/99

**** Subject to change without notice.**

MARATHON ELECTRIC CORPORATION

TYPICAL PERFORMANCE CURVE for AC MOTOR

Customer

Curve at

460

Volts

HP 3&2

PHASE 3

Model No 213TTFBD6085

60

HZ

VOLTS 230/460&190/380

3

HP

Catalog No GT3411A

HZ 60&50

RPM 1185&987

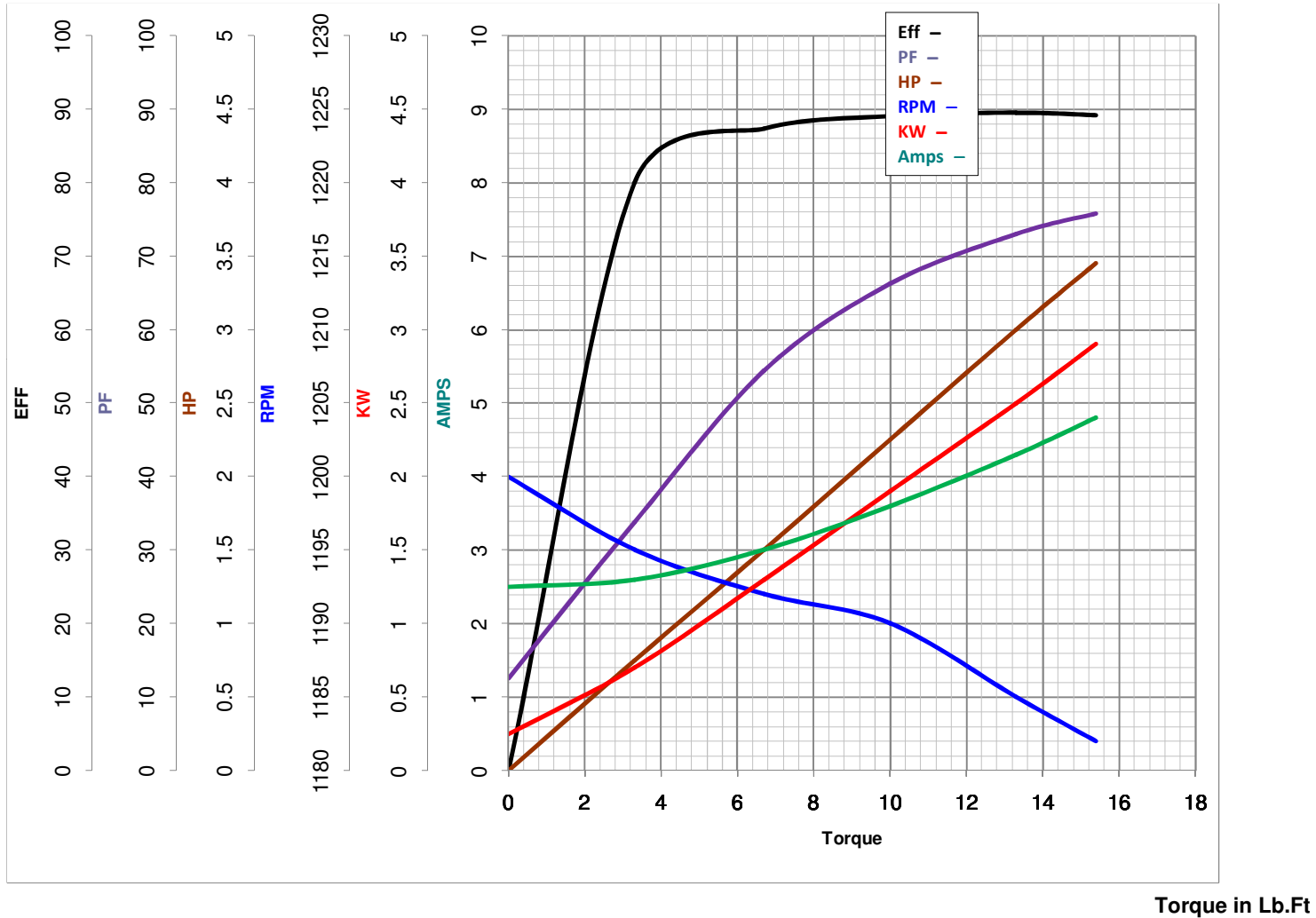

FL TORQUE 13.3 Lb.Ft
 BD TORQUE 37.0 Lb.Ft
 LR TORQUE 28 Lb.Ft

FL AMPS 8.6/4.3
 PU TORQUE 24.0 Lb.Ft
 LR AMPS 35

WINDING HE31326018-2 Prepared By FAREEDA

Date 5/4/2018