

PRODUCT INFORMATION PACKET

marathon[®]
Motors

Model No: 286TTFCD6006
Catalog No: GT3130A
30,3600,TEFC,286JM,3/60/230/460
JM



Regal and Marathon are trademarks of Regal Beloit Corporation or one of its affiliated companies.
©2018 Regal Beloit Corporation, All Rights Reserved. MC017097E

REGAL[®]



Nameplate Specifications

Output HP	30 Hp	Output KW	22.4 kW
Frequency	60 Hz	Voltage	230/460 V
Current	71.0/35.5 A	Speed	3550 rpm
Service Factor	1.15	Phase	3
Efficiency	91.7 %	Duty	Continuous
Insulation Class	F	Design Code	B
KVA Code	G	Frame	286JM
Enclosure	Totally Enclosed Fan Cooled	Overload Protector	No
Ambient Temperature	40 °C	Drive End Bearing Size	6311
Opp Drive End Bearing Size	6211	UL	Listed
CSA	Y	CE	Y
IP Code	55		

Technical Specifications

Electrical Type	Squirrel Cage Inverter Rated	Starting Method	Wye Start Delta Run Or Inverter
Poles	2	Rotation	Reversible
Mounting	Rigid base	Motor Orientation	Horizontal
Drive End Bearing	Ball	Opp Drive End Bearing	Ball
Frame Material	Cast Iron	Shaft Type	JM
Frame Length	12.91 in	Shaft Diameter	1.375 in
Shaft Extension	5.5 in	Assembly/Box Mounting	F1/F2 Capable
Outline Drawing	SS620797	Connection Diagram	EE7308AA

This is an uncontrolled document once printed or downloaded and is subject to change without notice. Date Created: 07/02/2018

OUTLINE

B

B

A

A

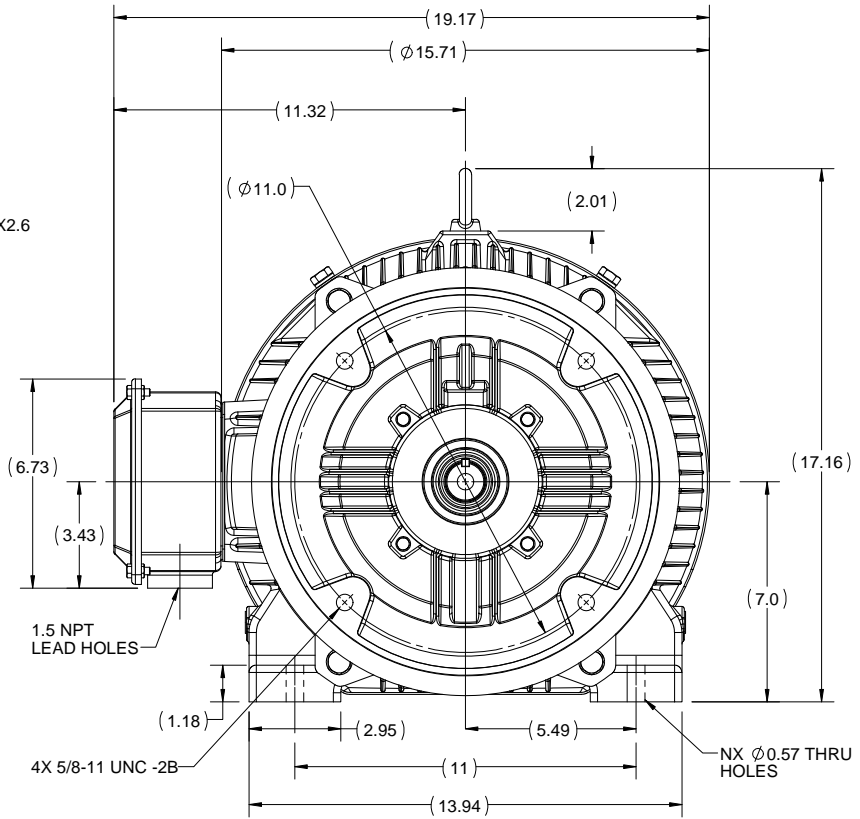
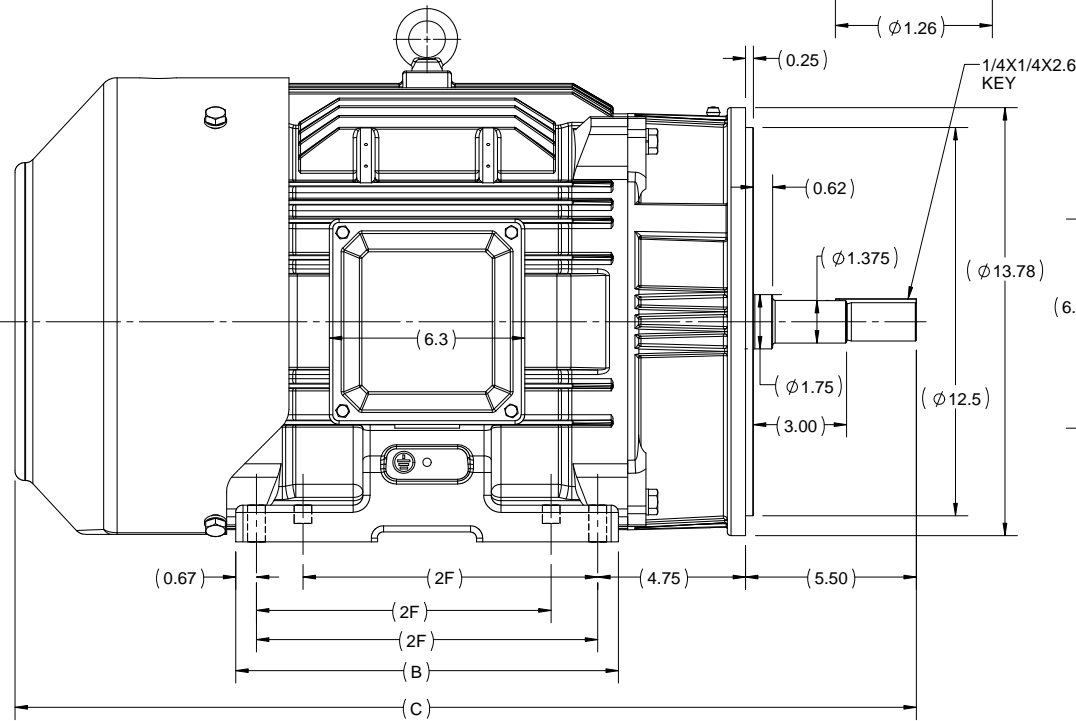
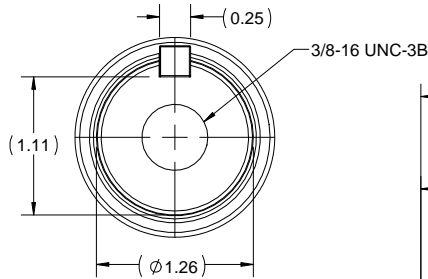

286-JM	12.32	29.02	11	8
284-JM	10.82	27.52	9.5	4
FRAME	B	C	2F	N

DRAWING REVISION A	REVISION BY SN	DATE 21/04/2017
ECO ECO-0122138	APPROVED BY SBD	DATE 21/04/2017
ECO DESCRIPTION NEW DRAWING RELEASE		
<small>COPYRIGHT REGAL BELOIT AMERICA, INC. ALL RIGHTS RESERVED. PROPRIETARY AND CONFIDENTIAL INFORMATION - THIS DOCUMENT IS THE PROPERTY OF REGAL BELOIT AMERICA, INC. (OWNER) AND CONTAINS OWNER'S PROPRIETARY INFORMATION. ANY PERSON, CORPORATION OR OTHER FIRM RECEIVING IT IS DEEMED, BY RECEIVING IT, TO AGREE THAT IT, AND/OR ANY PART OF IT, SHALL NOT BE DISCLOSED TO ANY PERSON, CORPORATION OR OTHER ENTITY, DUPLICATED, AND/OR USED, EXCEPT AS EXPRESSLY APPROVED IN WRITING IN ADVANCE BY OWNER. THIS DOCUMENT SHALL BE RETURNED TO OWNER UPON REQUEST. IT MAY BE SUBJECT TO CERTAIN RESTRICTIONS UNDER APPLICABLE EXPORT CONTROL LAWS AND REGULATIONS.</small>		

DRAWN BY SN	 REGAL-BELOIT CORPORATION
DATE 12/04/2017	
APPROVED BY SBD	DESCRIPTION OUTLINE
DATE 12/04/2017	TEFC-284/286 JM FR-CAST IRON
REFERENCE	MATERIAL
THIRD ANGLE PROJECTION	PROCESS/FINISH
SIZE B	DRAWING NUMBER SS620797
	SHEET 1 OF 1



LOW VOLTAGE



HIGH VOLTAGE



DRAWING REVISION K	REVISION BY AJW	DATE 07-17-2015
ECO ECO-0081632	APPROVED BY T. VUE	DATE 07-17-2015
ECO DESCRIPTION REV'D IEC MARKINGS PER IEC 60034-8		
COPYRIGHT REGAL BELOIT AMERICA, INC. ALL RIGHTS RESERVED. PROPRIETARY AND CONFIDENTIAL INFORMATION - THIS DOCUMENT IS THE PROPERTY OF REGAL BELOIT AMERICA, INC. ("OWNER") AND CONTAINS OWNER'S PROPRIETARY INFORMATION. ANY PERSON, CORPORATION OR OTHER FIRM RECEIVING IT IS DEEMED, BY RECEIVING IT, TO AGREE THAT IT, AND/OR ANY PART OF IT, SHALL NOT BE DISCLOSED TO ANY PERSON, CORPORATION OR OTHER ENTITY, DUPLICATED, AND/OR USED, EXCEPT AS EXPRESSLY APPROVED IN WRITING IN ADVANCE BY OWNER. THIS DOCUMENT SHALL BE RETURNED TO OWNER UPON REQUEST. IT MAY BE SUBJECT TO CERTAIN RESTRICTIONS UNDER APPLICABLE EXPORT CONTROL LAWS AND REGULATIONS.		



DRAWN BY LZ	Regal Beloit America, Inc.	
DATE 01-12-1994		
APPROVED BY GK	DESCRIPTION CONN DIAGRAM-EXTERNAL 3Ø-2/1 DELTA-12 LEADS	
DATE 01-14-1994		
REFERENCE	MATERIAL	PROCESS/FINISH
THIRD ANGLE PROJECTION	SIZE A	DRAWING NUMBER EE7308AA
		SHEET 1 OF 1



**P.O. BOX 8003
WAUSAU, WI 54401-8003
PH. 715-675-3311**

CERTIFICATION DATA SHEET

CUSTOMER: CUSTOMER PO #:
ORDER #: MODEL #: 286TTFCDD6006 AA
CONN. DIAGRAM: EE7308AA CUSTOMER PART #:
OUTLINE: SS620797 MOUNTING: F1/F2 CAPABLE
WINDING #: HE31802003 2

TYPICAL MOTOR PERFORMANCE DATA

HP	KW	SYNC. RPM	F.L. RPM	FRAME	ENCLOSURE	KVA CODE	DESIGN	
30825	22.4&18.7	3600	3550&2950	286JM	TEFC	G	B	
PH	HZ	VOLTS	AMPS	START TYPE	DUTY	INSL	S.F.	AMB°C
3	60/50	230/460&190/380	71/35.5&72/36	Y START D RUN OR INV	CONTINUOUS	F7	1.15/1.15	40

FULL LOAD EFF:	91.7&91.4	3/4 LOAD EFF:	91.7	1/2 LOAD EFF:	91.4	GTD. EFF	91	ELEC. TYPE
FULL LOAD PF:	86.5&887	3/4 LOAD PF:	83.5	1/2 LOAD PF:	75.5			SQ CAGE INV RATED

F.L. TORQUE	LOCKED ROTOR AMPS	L.R. TORQUE	B.D. TORQUE	F.L. RISE°C
44.4 LB-FT	420 / 210	77 LB-FT 173 %	107 LB-FT 241 %	65

SOUND PRESSURE @ 3 FT.	SOUND POWER	ROTOR WK^2	MAX. WK^2	SAFE STALL TIME	STARTS / HOUR	APPROX. MOTOR WGT
72 DBA	82 DBA	3.3 LB-FT^2	35 LB-FT^2	20 SEC.	2	500 LBS.

***** SUPPLEMENTAL INFORMATION *****

DE BRACKET TYPE	ODE BRACKET TYPE	MOUNT TYPE	ORIENTATION	SEVERE DUTY	HAZARDOUS LOCATION	DRIP COVER	SCREENS	PAINT
C-FACE	STANDARD	RIGID	HORIZONTAL	FALSE	DIVISION 2 T2B	FALSE	NONE	BLUE (ENAMEL)

BEARINGS		GREASE	SHAFT TYPE	SPECIAL DE	SPECIAL ODE	SHAFT MATERIAL	FRAME MATERIAL
DE	ODE						
BALL	BALL	POLYREX EM	JM	NONE	NONE	1045 HOT ROLLED (C-204)	CAST IRON
6311	6211						

THERMO-PROTECTORS				THERMISTORS			CONTROL		SPACE HEATERS	
THERMOSTATS	PROTECTORS	WDG RTDS	BRG RTDS				FALSE	NONE	NONE	VOLTS
NONE	NOT	NONE	NONE	NONE	NONE	NONE				

INVERTER
TORQUE: CONSTANT 10:1/VARIABLE 20:1
INV. HP SPEED RANGE: NONE

ENCODER: NONE
 NONE NONE
 NONE NONE PPR

BRAKE: NONE NONE
 NONE P/N NONE
 NONE NONE
 NONE FT-LB NONE V NONE HZ

PREPARED BY: Fareeda Dudekula
DATE: 05/04/2018 05:35:15 AM
FORM 3531 REV.3 02/07/99
 ** Subject to change without notice.

MARATHON ELECTRIC CORPORATION

TYPICAL PERFORMANCE CURVE for AC MOTOR

Customer

Curve at

460

Volts

HP 30&25

PHASE 3

Model No 286TTFC6006

60

HZ

VOLTS 230/460&190/380

30

HP

Catalog No GT3130A

HZ 60&50

RPM 3550&2950

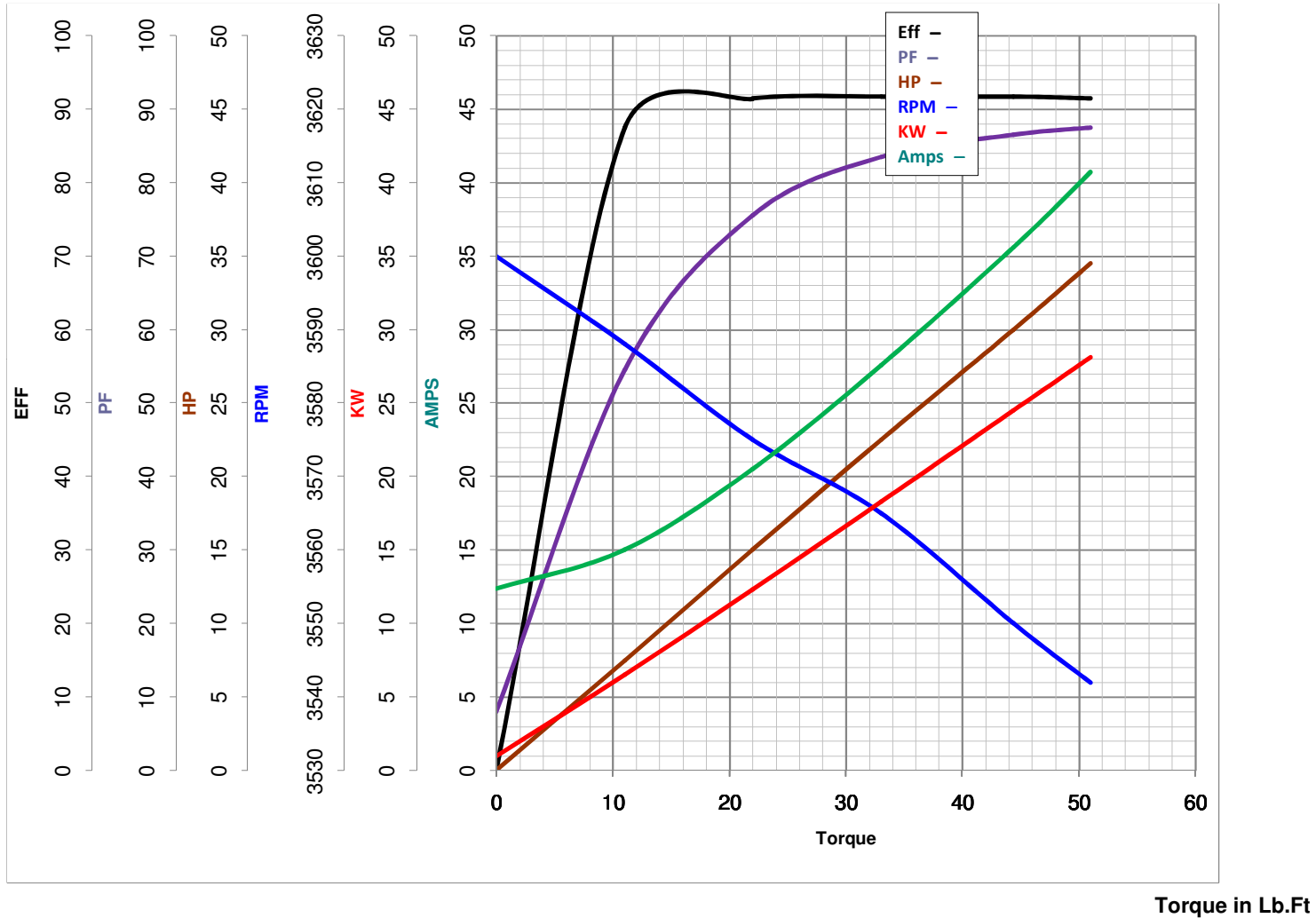

FL TORQUE 44.4 Lb.Ft
 BD TORQUE 107.0 Lb.Ft
 LR TORQUE 77 Lb.Ft

FL AMPS 71/35.5
 PU TORQUE 65.0 Lb.Ft
 LR AMPS 210

WINDING HE31802003-2 Prepared By FAREEDA

Date 5/4/2018