

PRODUCT INFORMATION PACKET

Model No: 324TTFCD6030
Catalog No: GT1134A
40,1800,TEFC,324T,3/60/575
Totally Enclosed Fan Cooled (TEFC)



Regal and Marathon are trademarks of Regal Beloit Corporation or one of its affiliated companies.
©2018 Regal Beloit Corporation, All Rights Reserved. MC017097E





Nameplate Specifications

Output HP	40 Hp	Output KW	30 kW
Frequency	60 Hz	Voltage	575 V
Current	38 A	Speed	1782 rpm
Service Factor	1.15	Phase	3
Efficiency	94.1 %	Duty	CONTINUOUS
Insulation Class	F	Design Code	B
KVA Code	G	Frame	324T
Enclosure	TEFC	Overload Protector	NOT
Ambient Temperature	40 °C	Drive End Bearing Size	6312
Opp Drive End Bearing Size	6212	UL	Listed
CSA	Y	CE	Y
IP Code	55		

Technical Specifications

Electrical Type	SQ CAGE INV RATED	Starting Method	LINE OR INVERTER
Poles	4	Rotation	REV
Mounting	RIGID	Motor Orientation	HORIZONTAL
Drive End Bearing	BALL	Opp Drive End Bearing	BALL
Frame Material	CAST IRON	Shaft Type	T
Overall Length	29.69 in	Shaft Diameter	2.13 in
Shaft Extension	5.25 in	Assembly/Box Mounting	F1/F2 CAPABLE
Outline Drawing	SS312782-324T	Connection Diagram	EE7300

This is an uncontrolled document once printed or downloaded and is subject to change without notice. Date Created: 04/05/2018

4

3

2

1

OUTLINE

B

B

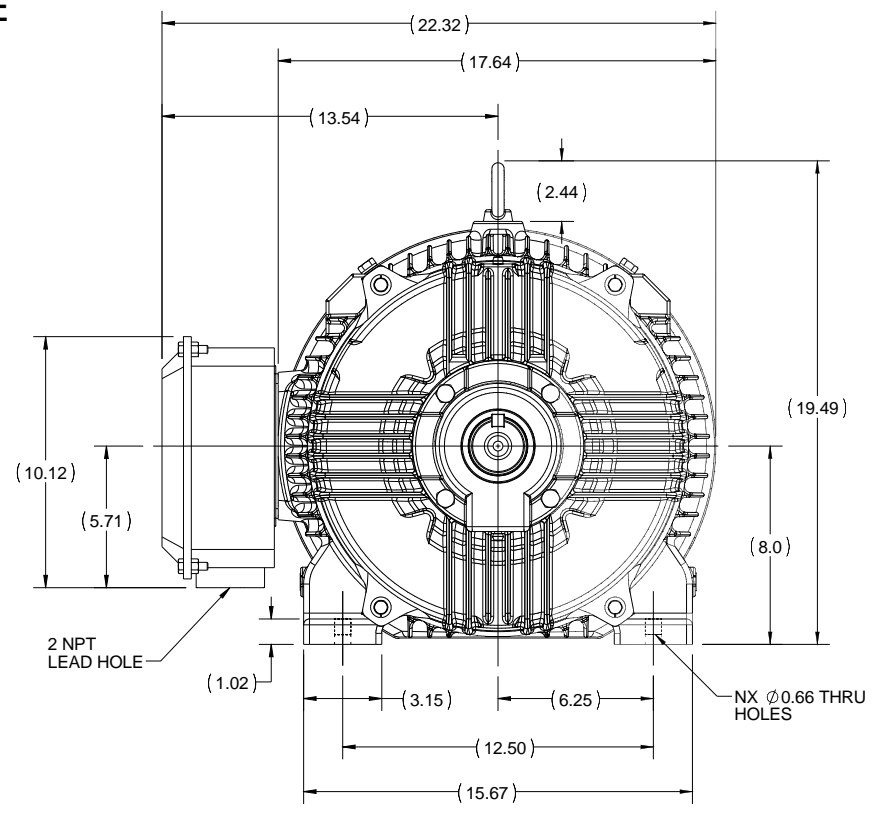
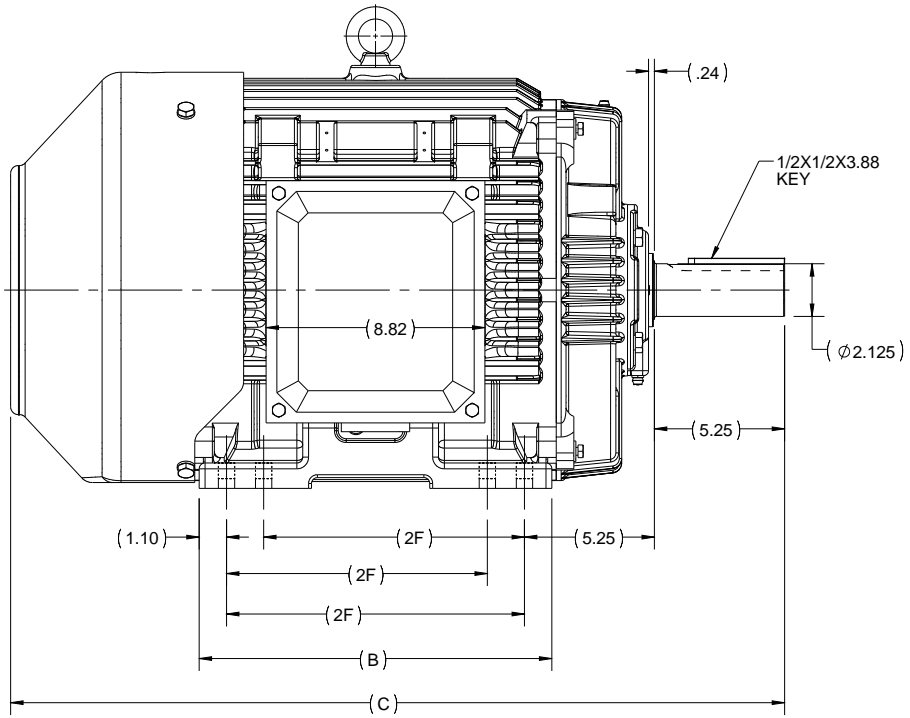



A

A

326T	14.21	31.19	12.0	8
324T	12.71	29.69	10.5	4
FRAME	B	C	2F	N

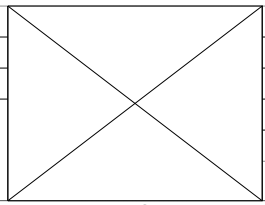
DRAWING REVISION A	REVISION BY UDAY	DATE 4/7/2016
ECO ECO-0105009	APPROVED BY RAJESH	DATE 4/7/2016
ECO DESCRIPTION NEW OUTLINE RELEASE		
<small>COPYRIGHT REGAL BELOIT AMERICA, INC. ALL RIGHTS RESERVED. PROPRIETARY AND CONFIDENTIAL INFORMATION - THIS DOCUMENT IS THE PROPERTY OF REGAL BELOIT AMERICA, INC. ("OWNER") AND CONTAINS OWNER'S PROPRIETARY INFORMATION. ANY PERSON, CORPORATION OR OTHER FIRM RECEIVING IT IS DEEMED, BY RECEIVING IT, TO AGREE THAT IT, AND/OR ANY PART OF IT, SHALL NOT BE DISCLOSED TO ANY PERSON, CORPORATION OR OTHER ENTITY, DUPLICATED, AND/OR USED, EXCEPT AS EXPRESSLY APPROVED IN WRITING IN ADVANCE BY OWNER. THIS DOCUMENT SHALL BE RETURNED TO OWNER UPON REQUEST. IT MAY BE SUBJECT TO CERTAIN RESTRICTIONS UNDER APPLICABLE EXPORT CONTROL LAWS AND REGULATIONS.</small>		



DRAWN BY NIV	 Regal Beloit America, Inc.
DATE 25/03/2016	
APPROVED BY SBD	DESCRIPTION OUTLINE 320T FR-TEFC
DATE 25/03/2016	MATERIAL
REFERENCE	PROCESS/FINISH
THIRD ANGLE PROJECTION	SIZE B
	DRAWING NUMBER SS312782
	SHEET 1 OF 1

**THREE PHASE - SINGLE VOLTAGE
MOTOR - CONDUIT BOX @ 'A'**

**TO REVERSE ROTATION:
INTERCHANGE ANY TWO
LINE LEAD CONNECTIONS.**

TERMINAL BLOCK WHEN SPECIFIED



VIEW OF TERMINAL END

**IF MOTOR HAS
6 LEADS**



A-9806 DECAL

**OPTIONAL CORD
CONNECTION**

- L1 _____ WHITE
- L2 _____ RED
- L3 _____ BLACK

DRAWING REVISION AB	REVISION BY JJB	DATE 06-27-2017
ECO ECO-0125361	APPROVED BY TB	DATE 06-27-2017
ECO DESCRIPTION UPDATED TO CURRENT STANDARDS		
<small>COPYRIGHT REGAL BELOIT AMERICA, INC. ALL RIGHTS RESERVED. PROPRIETARY AND CONFIDENTIAL INFORMATION - THIS DOCUMENT IS THE PROPERTY OF REGAL BELOIT AMERICA, INC. ("OWNER") AND CONTAINS OWNER'S PROPRIETARY INFORMATION. ANY PERSON, CORPORATION OR OTHER FIRM RECEIVING IT IS DEEMED, BY RECEIVING IT, TO AGREE THAT IT, AND/OR ANY PART OF IT, SHALL NOT BE DISCLOSED TO ANY PERSON, CORPORATION OR OTHER ENTITY, DUPLICATED, AND/OR USED, EXCEPT AS EXPRESSLY APPROVED IN WRITING IN ADVANCE BY OWNER. THIS DOCUMENT SHALL BE RETURNED TO OWNER UPON REQUEST. IT MAY BE SUBJECT TO CERTAIN RESTRICTIONS UNDER APPLICABLE EXPORT CONTROL LAWS AND REGULATIONS.</small>		



DRAWN BY DA
DATE 03-26-1993
APPROVED BY TB
DATE 03-26-1993
REFERENCE
THIRD ANGLE PROJECTION

Regal Beloit America, Inc.		
		DESCRIPTION CONNECTION DIAGRAM EXTERNAL - SINGLE VOLTAGE - 3Ø MOTOR
MATERIAL	PROCESS/FINISH	
SIZE A	DRAWING NUMBER EE7300	SHEET 1 OF 1

