

# PRODUCT INFORMATION PACKET

**marathon**<sup>®</sup>  
Motors

Model No: 284TSTFCD6005  
Catalog No: GT1127A  
25,3600,TEFC,284TS,3/60/575  
Totally Enclosed Fan Cooled (TEFC)



Regal and Marathon are trademarks of Regal Beloit Corporation or one of its affiliated companies.  
©2018 Regal Beloit Corporation, All Rights Reserved. MC017097E

**REGAL**<sup>®</sup>



### Nameplate Specifications

Output HP	<b>25 Hp</b>	Output KW	<b>18.7 kW</b>
Frequency	<b>60 Hz</b>	Voltage	<b>575 V</b>
Current	<b>24.0 A</b>	Speed	<b>3555 rpm</b>
Service Factor	<b>1.15</b>	Phase	<b>3</b>
Efficiency	<b>91.7 %</b>	Duty	<b>Continuous</b>
Insulation Class	<b>F</b>	Design Code	<b>B</b>
KVA Code	<b>G</b>	Frame	<b>284TS</b>
Enclosure	<b>Totally Enclosed Fan Cooled</b>	Overload Protector	<b>No</b>
Ambient Temperature	<b>40 °C</b>	Drive End Bearing Size	<b>6311</b>
Opp Drive End Bearing Size	<b>6211</b>	UL	<b>Listed</b>
CSA	<b>Y</b>	CE	<b>Y</b>
IP Code	<b>55</b>		

### Technical Specifications

Electrical Type	<b>Squirrel Cage Inverter Rated</b>	Starting Method	<b>Line Or Inverter</b>
Poles	<b>2</b>	Rotation	<b>Reversible</b>
Mounting	<b>Rigid base</b>	Motor Orientation	<b>Horizontal</b>
Drive End Bearing	<b>Ball</b>	Opp Drive End Bearing	<b>Ball</b>
Frame Material	<b>Cast Iron</b>	Shaft Type	<b>TS</b>
Frame Length	<b>11.41 in</b>	Shaft Diameter	<b>1.625 in</b>
Shaft Extension	<b>3.25 in</b>	Assembly/Box Mounting	<b>F1/F2 Capable</b>
Outline Drawing	<b>SS620698</b>	Connection Diagram	<b>EE7300</b>

This is an uncontrolled document once printed or downloaded and is subject to change without notice. Date Created: 07/02/2018

4

3

2

1

# OUTLINE

B

B

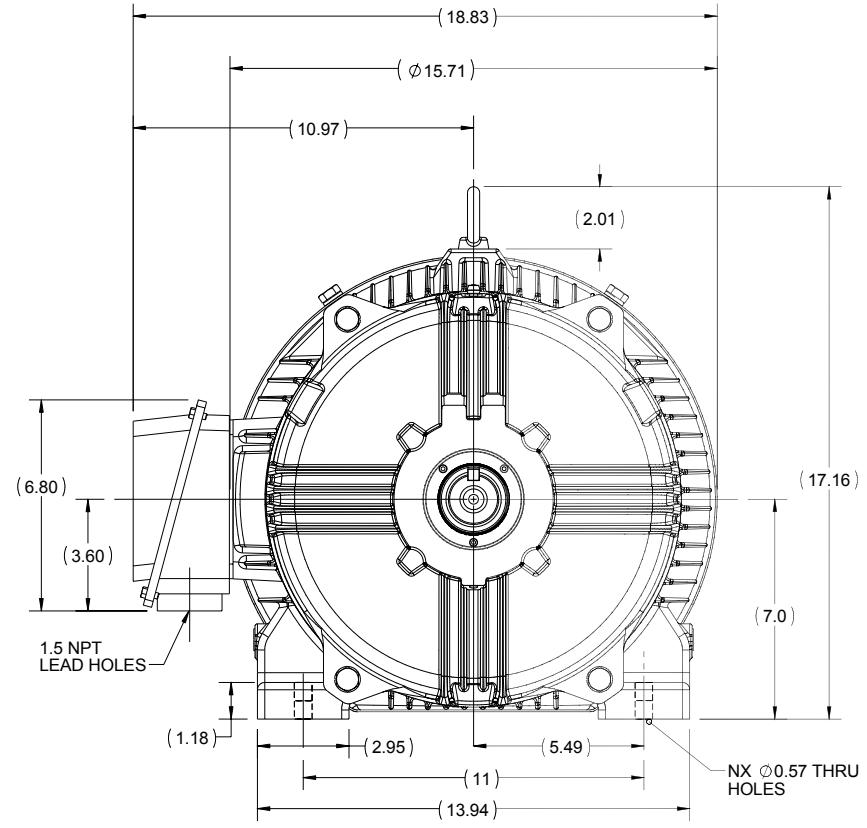
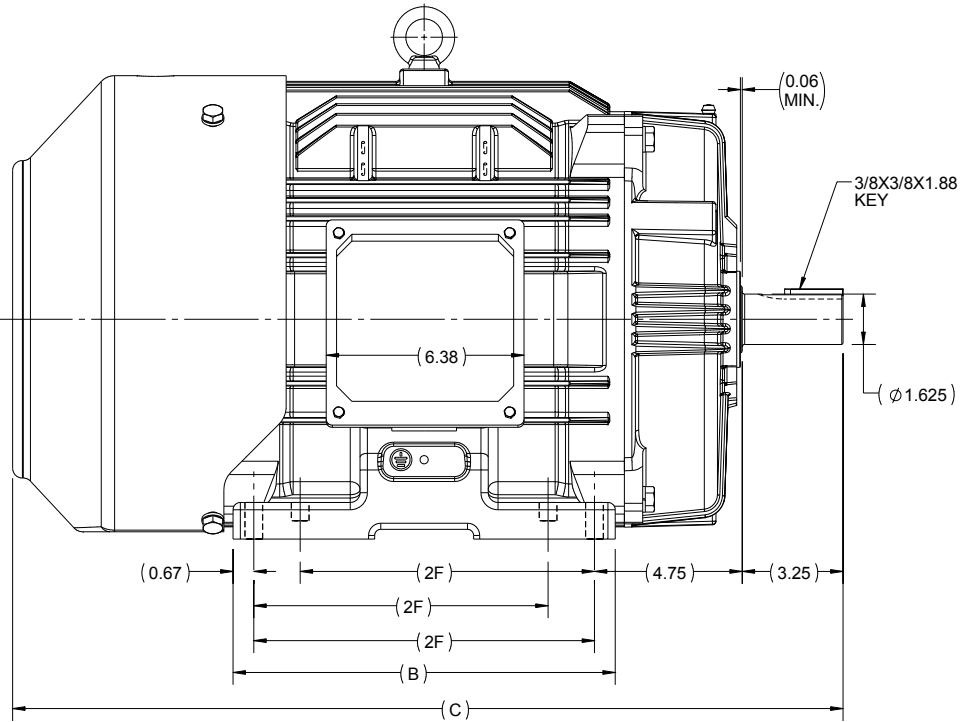

A

A

286	12.32	26.77	11	8
284	10.82	25.28	9.5	4
FRAME	B	C	2F	N

DRAWING REVISION A	REVISION BY UDAY	DATE 08/09/2015
ECO ECO-0084584	APPROVED BY SBD	DATE 08/09/2015
ECO DESCRIPTION NEW DRAWING RELEASE		
<small>COPYRIGHT REGAL BELOIT AMERICA, INC. ALL RIGHTS RESERVED.                  PROPRIETARY AND CONFIDENTIAL INFORMATION - THIS DOCUMENT IS THE PROPERTY OF                  REGAL BELOIT AMERICA, INC. ("OWNER") AND CONTAINS OWNER'S PROPRIETARY                  INFORMATION. ANY PERSON, CORPORATION OR OTHER FIRM RECEIVING IT IS DEEMED,                  BY RECEIVING IT, TO AGREE THAT IT, AND/OR ANY PART OF IT, SHALL NOT BE DISCLOSED                  TO ANY PERSON, CORPORATION OR OTHER ENTITY, DUPLICATED, AND/OR USED, EXCEPT                  AS EXPRESSLY APPROVED IN WRITING IN ADVANCE BY OWNER. THIS DOCUMENT SHALL                  BE RETURNED TO OWNER UPON REQUEST. IT MAY BE SUBJECT TO CERTAIN                  RESTRICTIONS UNDER APPLICABLE EXPORT CONTROL LAWS AND REGULATIONS.</small>		

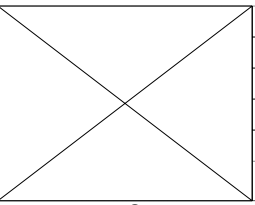

DRAWN BY SMAR
DATE 07/07/2015
APPROVED BY SBD
DATE 07/07/2015
REFERENCE
THIRD ANGLE PROJECTION

 <b>REGAL-BELOIT CORPORATION</b>	
DESCRIPTION <h2>OUTLINE</h2> 284/286TS FR-TEFC-CAST IRON	
MATERIAL	PROCESS/FINISH
SIZE B	DRAWING NUMBER SS620698
SHEET 1 OF 1	

4

3

2

1

**THREE PHASE - SINGLE VOLTAGE  
MOTOR - CONDUIT BOX @ 'A'**

**TO REVERSE ROTATION:  
INTERCHANGE ANY TWO  
LINE LEAD CONNECTIONS.**

**TERMINAL BLOCK WHEN SPECIFIED**

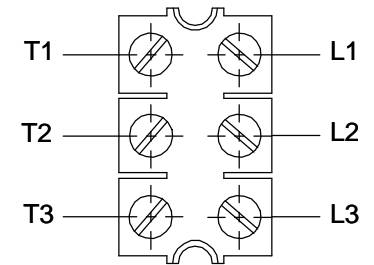

**VIEW OF TERMINAL END**

**IF MOTOR HAS  
6 LEADS**



A-9806 DECAL

**OPTIONAL CORD  
CONNECTION**



DRAWING REVISION <b>AB</b>	REVISION BY <b>JJB</b>	DATE <b>06-27-2017</b>
ECO <b>ECO-0125361</b>	APPROVED BY <b>TB</b>	DATE <b>06-27-2017</b>
ECO DESCRIPTION <b>UPDATED TO CURRENT STANDARDS</b>		
<small>COPYRIGHT REGAL BELOIT AMERICA, INC. ALL RIGHTS RESERVED.                  PROPRIETARY AND CONFIDENTIAL INFORMATION - THIS DOCUMENT IS THE PROPERTY OF                  REGAL BELOIT AMERICA, INC. ("OWNER") AND CONTAINS OWNER'S PROPRIETARY                  INFORMATION. ANY PERSON, CORPORATION OR OTHER FIRM RECEIVING IT IS DEEMED,                  BY RECEIVING IT, TO AGREE THAT IT, AND/OR ANY PART OF IT, SHALL NOT BE DISCLOSED                  TO ANY PERSON, CORPORATION OR OTHER ENTITY, DUPLICATED, AND/OR USED, EXCEPT                  AS EXPRESSLY APPROVED IN WRITING IN ADVANCE BY OWNER. THIS DOCUMENT SHALL                  BE RETURNED TO OWNER UPON REQUEST. IT MAY BE SUBJECT TO CERTAIN                  RESTRICTIONS UNDER APPLICABLE EXPORT CONTROL LAWS AND REGULATIONS.</small>		



DRAWN BY <b>DA</b>
DATE <b>03-26-1993</b>
APPROVED BY <b>TB</b>
DATE <b>03-26-1993</b>
REFERENCE
THIRD ANGLE PROJECTION

<b>Regal Beloit America, Inc.</b>	
DESCRIPTION <b>CONNECTION DIAGRAM EXTERNAL - SINGLE VOLTAGE - 3Ø MOTOR</b>	
MATERIAL	PROCESS/FINISH
SIZE <b>A</b>	DRAWING NUMBER <b>EE7300</b>
SHEET <b>1 OF 1</b>	



**P.O. BOX 8003  
WAUSAU, WI 54401-8003  
PH. 715-675-3311**

**CERTIFICATION DATA SHEET**

**CUSTOMER:** CUSTOMER PO #:  
**ORDER #:** MODEL #: 284TSTFCD6005 AA  
**CONN. DIAGRAM:** EE7300 CUSTOMER PART #:  
**OUTLINE:** SS620698 MOUNTING: F1/F2 CAPABLE  
**WINDING #:** HE31802004 3

**TYPICAL MOTOR PERFORMANCE DATA**

HP	KW	SYNC. RPM	F.L. RPM	FRAME	ENCLOSURE	KVA CODE	DESIGN	
25	18.7	3600	3555	284TS	TEFC	G	B	
PH	HZ	VOLTS	AMPS	START TYPE	DUTY	INSL	S.F.	AMB°C
3	60	575	24	LINE OR INVERTER	CONTINUOUS	F7	1.15	40

<b>FULL LOAD EFF:</b>	91.7	<b>3/4 LOAD EFF:</b>	91.7	<b>1/2 LOAD EFF:</b>	91	<b>GTD. EFF</b>	91	<b>ELEC. TYPE</b>
<b>FULL LOAD PF:</b>	86	<b>3/4 LOAD PF:</b>	82	<b>1/2 LOAD PF:</b>	73.5	<b>SQ CAGE INV RATED</b>		
<b>F.L. TORQUE</b>	<b>LOCKED ROTOR AMPS</b>	<b>L.R. TORQUE</b>	<b>B.D. TORQUE</b>	<b>F.L. RISE°C</b>				
37 LB-FT	144.8	65 LB-FT	176 %	94 LB-FT	254 %	55		

<b>SOUND PRESSURE @ 3 FT.</b>	<b>SOUND POWER</b>	<b>ROTOR WK^2</b>	<b>MAX. WK^2</b>	<b>SAFE STALL TIME</b>	<b>STARTS / HOUR</b>	<b>APPROX. MOTOR WGT</b>
72 DBA	82 DBA	2.9 LB-FT^2	32 LB-FT^2	20 SEC.	2	460 LBS.

**\*\*\* SUPPLEMENTAL INFORMATION \*\*\***

DE BRACKET TYPE	ODE BRACKET TYPE	MOUNT TYPE	ORIENTATION	SEVERE DUTY	HAZARDOUS LOCATION	DRIP COVER	SCREENS	PAINT
STANDARD	STANDARD	RIGID	HORIZONTAL	FALSE	DIVISION 2 T2B	FALSE	NONE	BLUE (ENAMEL)
BEARINGS		GREASE	SHAFT TYPE	SPECIAL DE	SPECIAL ODE	SHAFT MATERIAL	FRAME MATERIAL	
DE ODE	BALL BALL	POLYREX EM	TS	NONE	NONE	1045 HOT ROLLED (C-204)	CAST IRON	
6311	6211							

THERMO-PROTECTORS				THERMISTORS			SPACE HEATERS	
THERMOSTATS	PROTECTORS	WDG RTDS	BRG RTDS	NONE	FALSE	NONE	NONE	VOLTS
NONE	NOT	NONE	NONE					

**INVERTER**  
**TORQUE:** CONSTANT 20:1/VARIABLE 20:1  
**INV. HP SPEED RANGE:** NONE

**ENCODER:** NONE  
 NONE NONE  
 NONE NONE PPR  
**BRAKE:** NONE NONE  
 NONE P/N NONE  
 NONE NONE  
 NONE FT-LB NONE V NONE HZ

**PREPARED BY:** Fareeda Dudekula  
**DATE:** 05/04/2018 08:04:57 AM  
**FORM 3531 REV.3 02/07/99**  
 \*\* Subject to change without notice.

**MARATHON ELECTRIC CORPORATION**

TYPICAL PERFORMANCE CURVE for AC MOTOR

Customer

Curve at

575

Volts

HP 25.00

PHASE 3

Model No 284TSTFCD6005

60

HZ

VOLTS 575

25

HP

Catalog No GT1127A

HZ 60

RPM 3555

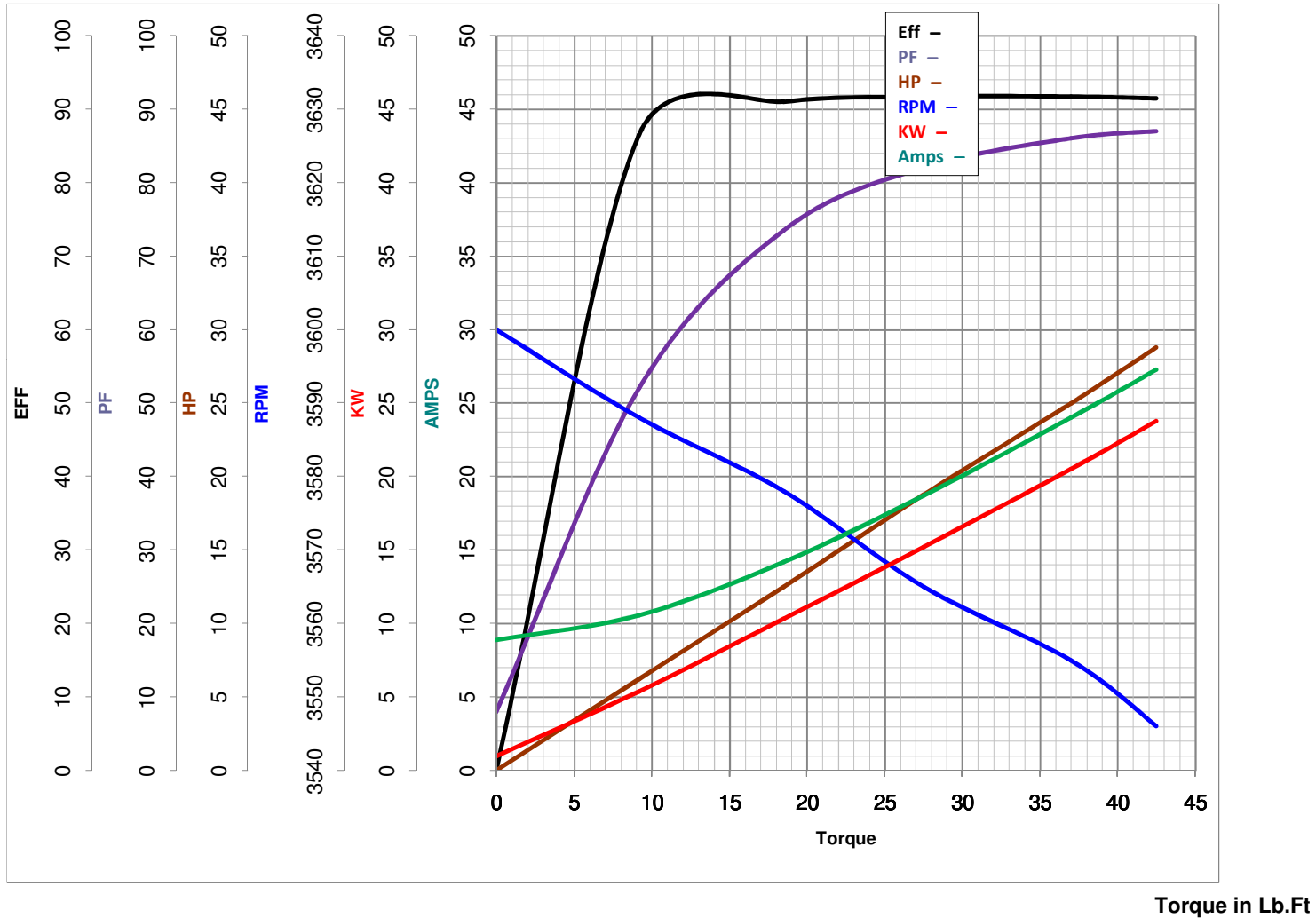

FL TORQUE 37 Lb.Ft  
 BD TORQUE 94.0 Lb.Ft  
 LR TORQUE 65 Lb.Ft

FL AMPS 24  
 PU TORQUE 56.0 Lb.Ft  
 LR AMPS 144.8

WINDING HE31802004-3 Prepared By FAREEDA

Date 5/4/2018