

PRODUCT INFORMATION PACKET

marathon[®]
Motors

Model No: 405TSTFCD6036
Catalog No: GT1063
100,1800,TEFC,405TS,3/60/230/460
Totally Enclosed Fan Cooled (TEFC)



Regal and Marathon are trademarks of Regal Beloit Corporation or one of its affiliated companies.
©2018 Regal Beloit Corporation, All Rights Reserved. MC017097E

REGAL[®]

Nameplate Specifications

Output HP	100 Hp	Output KW	75.0 kW
Frequency	60 Hz	Voltage	230/460 V
Current	226.0/113.0 A	Speed	1785 rpm
Service Factor	1.15	Phase	3
Efficiency	95.4 %	Duty	Continuous
Insulation Class	F	Design Code	B
KVA Code	G	Frame	405TS
Enclosure	Totally Enclosed Fan Cooled	Overload Protector	No
Ambient Temperature	40 °C	Drive End Bearing Size	6316
Opp Drive End Bearing Size	6314	UL	Listed
CSA	Y	CE	Y
IP Code	55		

Technical Specifications

Electrical Type	Squirrel Cage Inverter Rated	Starting Method	Wye Start Delta Run Or Inverter
Poles	4	Rotation	Reversible
Mounting	Rigid base	Motor Orientation	Horizontal
Drive End Bearing	Ball	Opp Drive End Bearing	Ball
Frame Material	Cast Iron	Shaft Type	TS
Frame Length	18.11 in	Shaft Diameter	2.125 in
Shaft Extension	4.25 in	Assembly/Box Mounting	F1/F2 Capable
Outline Drawing	SS557004	Connection Diagram	EE7308AA

This is an uncontrolled document once printed or downloaded and is subject to change without notice. Date Created: 07/02/2018

OUTLINE

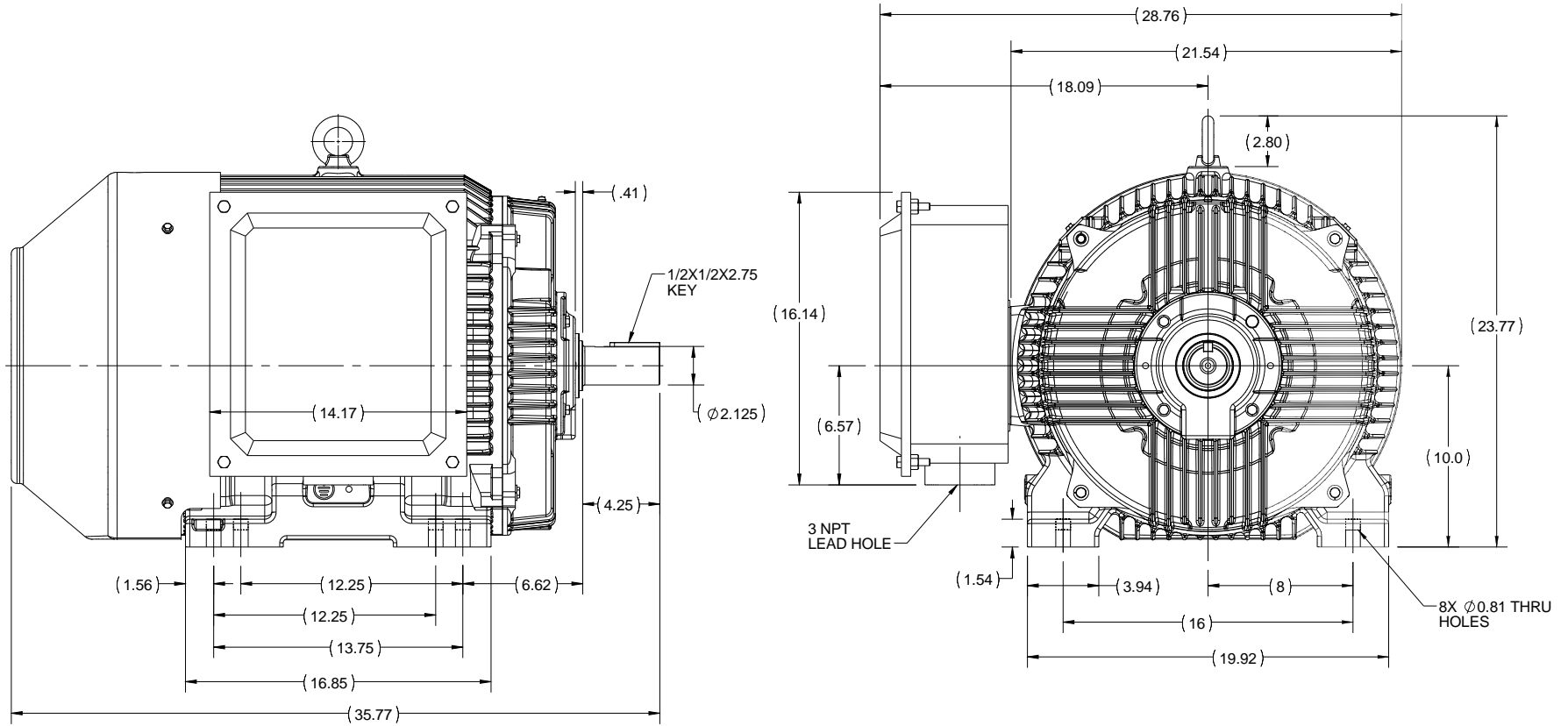

DRAWING REVISION A	REVISION BY MVG	DATE 05/07/16
ECO ECO-0105009	APPROVED BY SBD	DATE 05/07/16
ECO DESCRIPTION NEW OUTLINE RELEASE		
<small>COPYRIGHT REGAL BELOIT AMERICA, INC. ALL RIGHTS RESERVED. PROPRIETARY AND CONFIDENTIAL INFORMATION - THIS DOCUMENT IS THE PROPERTY OF REGAL BELOIT AMERICA, INC. ("OWNER") AND CONTAINS OWNER'S PROPRIETARY INFORMATION. ANY PERSON, CORPORATION OR OTHER FIRM RECEIVING IT IS DEEMED, BY RECEIVING IT, TO AGREE THAT IT, AND/OR ANY PART OF IT, SHALL NOT BE DISCLOSED TO ANY PERSON, CORPORATION OR OTHER ENTITY, DUPLICATED, AND/OR USED, EXCEPT AS EXPRESSLY APPROVED IN WRITING IN ADVANCE BY OWNER. THIS DOCUMENT SHALL BE RETURNED TO OWNER UPON REQUEST. IT MAY BE SUBJECT TO CERTAIN RESTRICTIONS UNDER APPLICABLE EXPORT CONTROL LAWS AND REGULATIONS.</small>		

DRAWN BY NIV	 Regal Beloit America, Inc.
DATE 25/03/2016	
APPROVED BY SBD	DESCRIPTION OUTLINE 405TS FR-TEFC
DATE 25/03/2016	MATERIAL
REFERENCE	PROCESS/FINISH
THIRD ANGLE PROJECTION	SIZE B
	DRAWING NUMBER SS557004
	SHEET 1 OF 1



LOW VOLTAGE



HIGH VOLTAGE



VIEW OF TERMINAL END

DRAWING REVISION K	REVISION BY AJW	DATE 07-17-2015
ECO ECO-0081632	APPROVED BY T. VUE	DATE 07-17-2015
ECO DESCRIPTION REV'D IEC MARKINGS PER IEC 60034-8		
<small>COPYRIGHT REGAL BELOIT AMERICA, INC. ALL RIGHTS RESERVED. PROPRIETARY AND CONFIDENTIAL INFORMATION - THIS DOCUMENT IS THE PROPERTY OF REGAL BELOIT AMERICA, INC. ("OWNER") AND CONTAINS OWNER'S PROPRIETARY INFORMATION. ANY PERSON, CORPORATION OR OTHER FIRM RECEIVING IT IS DEEMED, BY RECEIVING IT, TO AGREE THAT IT, AND/OR ANY PART OF IT, SHALL NOT BE DISCLOSED TO ANY PERSON, CORPORATION OR OTHER ENTITY, DUPLICATED, AND/OR USED, EXCEPT AS EXPRESSLY APPROVED IN WRITING IN ADVANCE BY OWNER. THIS DOCUMENT SHALL BE RETURNED TO OWNER UPON REQUEST. IT MAY BE SUBJECT TO CERTAIN RESTRICTIONS UNDER APPLICABLE EXPORT CONTROL LAWS AND REGULATIONS.</small>		

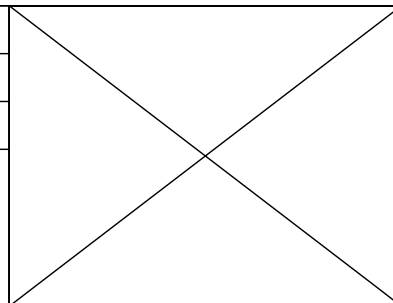

DRAWN BY LZ	Regal Beloit America, Inc.	
DATE 01-12-1994		
APPROVED BY GK	DESCRIPTION CONN DIAGRAM-EXTERNAL 3Ø-2/1 DELTA-12 LEADS	
DATE 01-14-1994		
REFERENCE	MATERIAL	PROCESS/FINISH
THIRD ANGLE PROJECTION	SIZE A	DRAWING NUMBER EE7308AA
		SHEET 1 OF 1



**P.O. BOX 8003
WAUSAU, WI 54401-8003
PH. 715-675-3311**

CERTIFICATION DATA SHEET

CUSTOMER:
ORDER #:
CONN. DIAGRAM:
OUTLINE:
WINDING #:

CUSTOMER PO #:
MODEL #:
CUSTOMER PART #:
MOUNTING:

TYPICAL MOTOR PERFORMANCE DATA

HP	KW	SYNC. RPM	F.L. RPM	FRAME	ENCLOSURE	KVA CODE	DESIGN	
100&75	75.0&56.0	1800	1785&1488	40STS	TEFC	G	B	
PH	HZ	VOLTS	AMPS	START TYPE	DUTY	INSL	S.F.	AMB°C
3	60/50	230/460&190/380	226/113&208/104	Y START D RUN OR INV	CONTINUOUS	F7	1.15/1.15	40

FULL LOAD EFF:	95.4&95	3/4 LOAD EFF:	95.4	1/2 LOAD EFF:	95	GTD. EFF	95	ELEC. TYPE
FULL LOAD PF:	87&86	3/4 LOAD PF:	83.5	1/2 LOAD PF:	74.5	95	SQ CAGE INV RATED	

F.L. TORQUE	LOCKED ROTOR AMPS	L.R. TORQUE	B.D. TORQUE	F.L. RISE°C
294 LB-FT	1450 / 725	529 LB-FT 180 %	764 LB-FT 260 %	65

SOUND PRESSURE @ 3 FT.	SOUND POWER	ROTOR WK^2	MAX. WK^2	SAFE STALL TIME	STARTS / HOUR	APPROX. MOTOR WGT
75 DBA	85 DBA	35 LB-FT^2	550 LB-FT^2	25 SEC.	2	1575 LBS.

***** SUPPLEMENTAL INFORMATION *****

DE BRACKET TYPE	ODE BRACKET TYPE	MOUNT TYPE	ORIENTATION	SEVERE DUTY	HAZARDOUS LOCATION	DRIP COVER	SCREENS	PAINT
STANDARD	STANDARD	RIGID	HORIZONTAL	FALSE	DIVISION 2 T2B	FALSE	NONE	BLUE (ENAMEL)

BEARINGS		GREASE	SHAFT TYPE	SPECIAL DE	SPECIAL ODE	SHAFT MATERIAL	FRAME MATERIAL
DE	ODE						
BALL	BALL	POLYREX EM	TS	NONE	NONE	1045 HOT ROLLED (C-204)	CAST IRON
6316	6314						

THERMO-PROTECTORS				THERMISTORS			SPACE HEATERS	
THERMOSTATS	PROTECTORS	WDG RTDS	BRG RTDS	NONE	FALSE	NONE	NONE	VOLTS
NONE	NOT	NONE	NONE					

INVERTER
TORQUE: CONSTANT 10:1/VARIABLE 20:1
INV. HP SPEED RANGE: NONE

ENCODER: NONE
NONE NONE
NONE NONE PPR

BRAKE: NONE NONE
NONE P/N NONE
NONE NONE
NONE FT-LB NONE V NONE HZ

PREPARED BY: Anusha Muthyala
DATE: 05/04/2018 12:41:48 AM
FORM 3531 REV.3 02/07/99
** Subject to change without notice.

MARATHON ELECTRIC CORPORATION

TYPICAL PERFORMANCE CURVE for AC MOTOR

Customer _____ Curve at 460 Volts HP 100&75 PHASE 3
 Model No 405TSTFC6036 60 HZ
100 HP VOLTS 230/460&190/380
 Catalog No GT1063 HZ 60&50 RPM 1785&1488

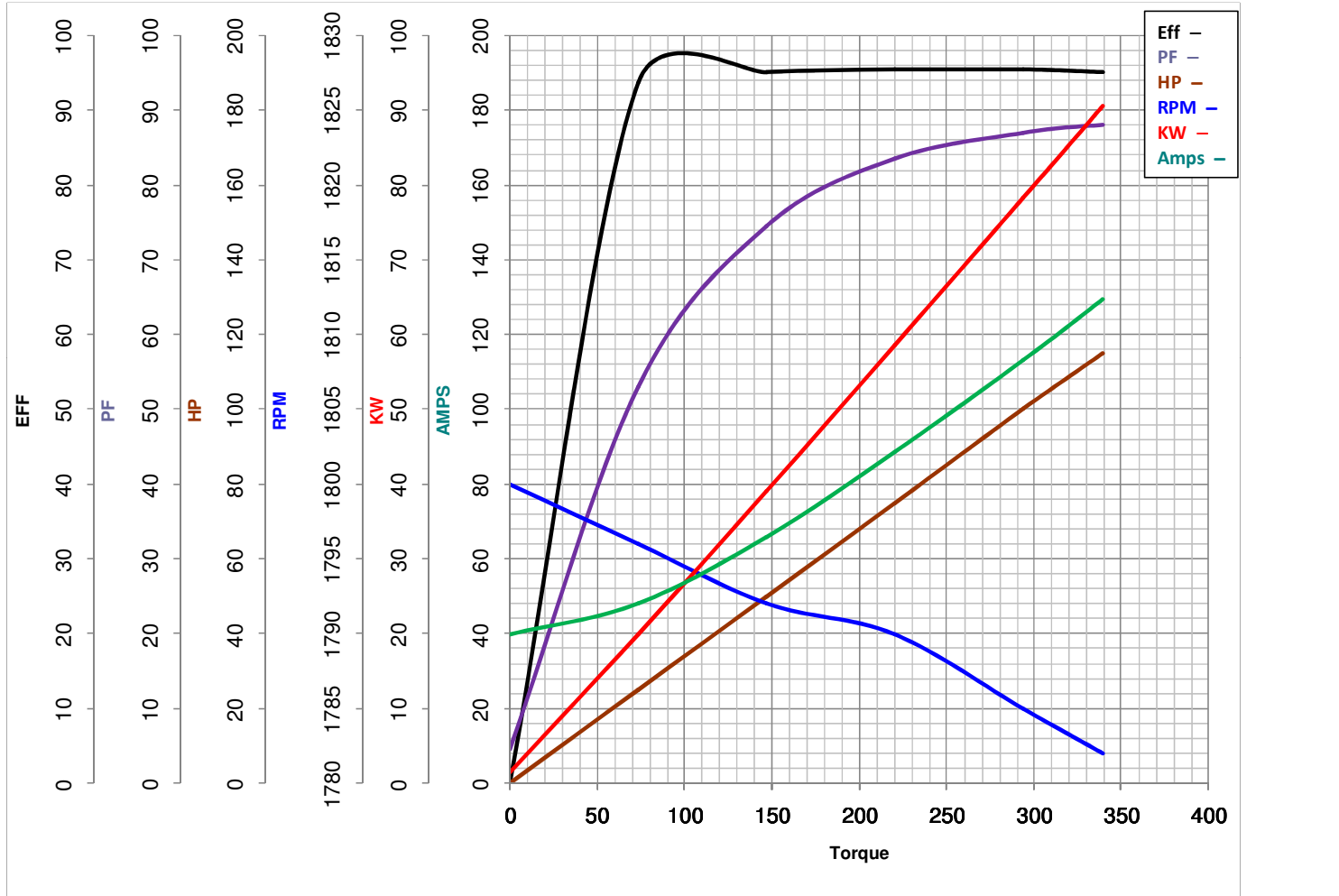

FL TORQUE	<u>294</u>	Lb.Ft	FL AMPS	<u>226/113</u>
BD TORQUE	<u>764.0</u>	Lb.Ft	PU TORQUE	<u>445.0</u> Lb.Ft
LR TORQUE	<u>529</u>	Lb.Ft	LR AMPS	<u>725</u>
WINDING	HE32504006-2	Prepared By	ANUSHA M	Date 5/4/2018