

PRODUCT INFORMATION PACKET

Model No: 365TSTFCD6036
Catalog No: GT1062
Totally Enclosed Fan Cooled (TEFC)



Regal and Marathon are trademarks of Regal Beloit Corporation or one of its affiliated companies.
©2018 Regal Beloit Corporation, All Rights Reserved. MC017097E



Nameplate Specifications

Output HP	75 Hp	Output KW	56.0 kW
Frequency	60 Hz	Voltage	230/460 V
Current	171.0/85.5 A	Speed	1782 rpm
Service Factor	1.15	Phase	3
Efficiency	95.4 %	Duty	Continuous
Insulation Class	F	Design Code	B
KVA Code	G	Frame	365TS
Enclosure	Totally Enclosed Fan Cooled	Overload Protector	No
Ambient Temperature	40 °C	Drive End Bearing Size	6313
Opp Drive End Bearing Size	6212	UL	Listed
CSA	Y	CE	Y
IP Code	55		

Technical Specifications

Electrical Type	Squirrel Cage Inverter Rated	Starting Method	Wye Start Delta Run Or Inverter
Poles	4	Rotation	Reversible
Mounting	Rigid base	Motor Orientation	Horizontal
Drive End Bearing	Ball	Opp Drive End Bearing	Ball
Frame Material	Cast Iron	Shaft Type	TS
Frame Length	16.73 in	Shaft Diameter	1.875 in
Shaft Extension	3.75 in	Assembly/Box Mounting	F1/F2 Capable
Outline Drawing	SS556998TS-365	Connection Diagram	EE7308AA

This is an uncontrolled document once printed or downloaded and is subject to change without notice. Date Created: 07/02/2018

OUTLINE

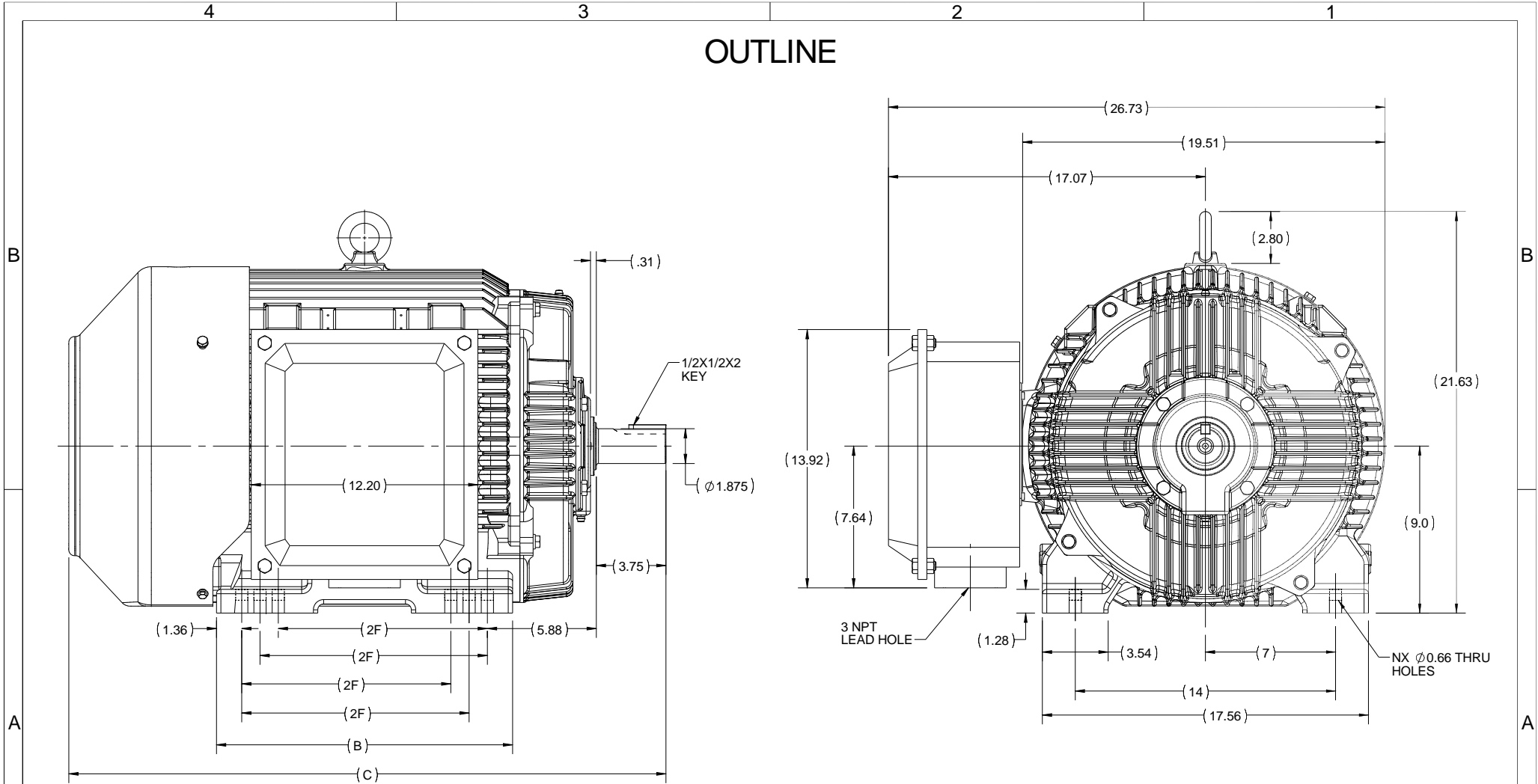

365TS	15.94	32.17	12.25	12
364TS	14.96	31.19	11.25	8
FRAME	B	C	2F	N

DRAWING REVISION A	REVISION BY UDAY	DATE 4/7/2016
ECO ECO-0105009	APPROVED BY SBD	DATE 4/7/2016
ECO DESCRIPTION NEW OUTLINE RELEASE		
<small>COPYRIGHT REGAL BELOIT AMERICA, INC. ALL RIGHTS RESERVED. PROPRIETARY AND CONFIDENTIAL INFORMATION - THIS DOCUMENT IS THE PROPERTY OF REGAL BELOIT AMERICA, INC. (OWNER) AND CONTAINS OWNER'S PROPRIETARY INFORMATION. ANY PERSON, CORPORATION OR OTHER FIRM RECEIVING IT IS DEEMED, BY RECEIVING IT, TO AGREE THAT IT, AND/OR ANY PART OF IT, SHALL NOT BE DISCLOSED TO ANY PERSON, CORPORATION OR OTHER ENTITY, DUPLICATED, AND/OR USED, EXCEPT AS EXPRESSLY APPROVED IN WRITING IN ADVANCE BY OWNER. THIS DOCUMENT SHALL BE RETURNED TO OWNER UPON REQUEST. IT MAY BE SUBJECT TO CERTAIN RESTRICTIONS UNDER APPLICABLE EXPORT CONTROL LAWS AND REGULATIONS.</small>		

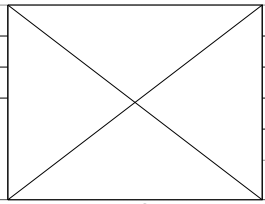

DRAWN BY NIV	 Regal Beloit America, Inc.		
DATE 25/03/2016			
APPROVED BY SBD	DESCRIPTION OUTLINE 360TS FR-TEFC		
DATE 25/03/2016	MATERIAL		
REFERENCE	PROCESS/FINISH		
THIRD ANGLE PROJECTION	SIZE B	DRAWING NUMBER SS556998	SHEET 1 OF 1



LOW VOLTAGE



HIGH VOLTAGE



DRAWING REVISION K	REVISION BY AJW	DATE 07-17-2015
ECO ECO-0081632	APPROVED BY T. VUE	DATE 07-17-2015
ECO DESCRIPTION REV'D IEC MARKINGS PER IEC 60034-8		
<small>COPYRIGHT REGAL BELOIT AMERICA, INC. ALL RIGHTS RESERVED. PROPRIETARY AND CONFIDENTIAL INFORMATION - THIS DOCUMENT IS THE PROPERTY OF REGAL BELOIT AMERICA, INC. ("OWNER") AND CONTAINS OWNER'S PROPRIETARY INFORMATION. ANY PERSON, CORPORATION OR OTHER FIRM RECEIVING IT IS DEEMED, BY RECEIVING IT, TO AGREE THAT IT, AND/OR ANY PART OF IT, SHALL NOT BE DISCLOSED TO ANY PERSON, CORPORATION OR OTHER ENTITY, DUPLICATED, AND/OR USED, EXCEPT AS EXPRESSLY APPROVED IN WRITING IN ADVANCE BY OWNER. THIS DOCUMENT SHALL BE RETURNED TO OWNER UPON REQUEST. IT MAY BE SUBJECT TO CERTAIN RESTRICTIONS UNDER APPLICABLE EXPORT CONTROL LAWS AND REGULATIONS.</small>		



DRAWN BY LZ	Regal Beloit America, Inc.	
DATE 01-12-1994		
APPROVED BY GK	DESCRIPTION CONN DIAGRAM-EXTERNAL 3Ø-2/1 DELTA-12 LEADS	
DATE 01-14-1994		
REFERENCE	MATERIAL	PROCESS/FINISH
THIRD ANGLE PROJECTION	SIZE A	DRAWING NUMBER EE7308AA
		SHEET 1 OF 1



**P.O. BOX 8003
WAUSAU, WI 54401-8003
PH. 715-675-3311**

CERTIFICATION DATA SHEET

CUSTOMER: CUSTOMER PO #:
ORDER #: MODEL #: 365TSTFCD6036 AA
CONN. DIAGRAM: EE7308AA CUSTOMER PART #:
OUTLINE: SSS56998TS-365 MOUNTING: F1/F2 CAPABLE
WINDING #: HE32254009 2

TYPICAL MOTOR PERFORMANCE DATA

HP	KW	SYNC. RPM	F.L. RPM	FRAME	ENCLOSURE	KVA CODE	DESIGN	
75860	56.0&45.0	1800	1782&1482	365TS	TEFC	G	B	
PH	HZ	VOLTS	AMPS	START TYPE	DUTY	INSL	S.F.	AMB°C
3	60/50	230/460&190/380	171/85.5&166/83	Y START D RUN OR INV	CONTINUOUS	F7	1.15/1.15	40

FULL LOAD EFF:	95.4&95.2	3/4 LOAD EFF:	95.4	1/2 LOAD EFF:	95	GTD. EFF	95	ELEC. TYPE
FULL LOAD PF:	86&86	3/4 LOAD PF:	83.5	1/2 LOAD PF:	76.2	SQ CAGE INV RATED		
F.L. TORQUE	LOCKED ROTOR AMPS	L.R. TORQUE	B.D. TORQUE	F.L. RISE°C				
221 LB-FT	1084 / 542	464 LB-FT	210 %	586 LB-FT	265 %	65		

SOUND PRESSURE @ 3 FT.	SOUND POWER	ROTOR WK^2	MAX. WK^2	SAFE STALL TIME	STARTS / HOUR	APPROX. MOTOR WGT
70 DBA	80 DBA	20.5 LB-FT^2	- LB-FT^2	20 SEC.	2	1050 LBS.

*** SUPPLEMENTAL INFORMATION ***

DE BRACKET TYPE	ODE BRACKET TYPE	MOUNT TYPE	ORIENTATION	SEVERE DUTY	HAZARDOUS LOCATION	DRIP COVER	SCREENS	PAINT
STANDARD	STANDARD	RIGID	HORIZONTAL	FALSE	DIVISION 2 T2B	FALSE	NONE	BLUE (ENAMEL)
BEARINGS		SHAFT TYPE	SPECIAL DE	SPECIAL ODE	SHAFT MATERIAL	FRAME MATERIAL		
DE ODE	GREASE							
BALL BALL	POLYREX EM	TS	NONE	NONE	1045 HOT ROLLED (C-204)	CAST IRON		
6313	6212							

THERMO-PROTECTORS				THERMISTORS			SPACE HEATERS	
THERMOSTATS	PROTECTORS	WDG RTDS	BRG RTDS	NONE	FALSE	NONE	NONE	VOLTS
NONE	NOT	NONE	NONE					

INVERTER
TORQUE: CONSTANT 10:1/VARIABLE 20:1
INV. HP SPEED RANGE: NONE

ENCODER: NONE
 NONE NONE
 NONE NONE PPR
BRAKE: NONE NONE
 NONE P/N NONE
 NONE NONE
 NONE FT-LB NONE V NONE HZ

*
PREPARED BY: Fareeda Dudekula
DATE: 05/04/2018 04:38:36 AM
FORM 3531 REV.3 02/07/99
 ** Subject to change without notice.

MARATHON ELECTRIC CORPORATION

TYPICAL PERFORMANCE CURVE for AC MOTOR

Customer

Curve at

460

Volts

HP 75&60

PHASE 3

Model No 365TSTFCD6036

60

HZ

VOLTS 230/460&190/380

75

HP

Catalog No GT1062

HZ 60&50

RPM 1782&1482

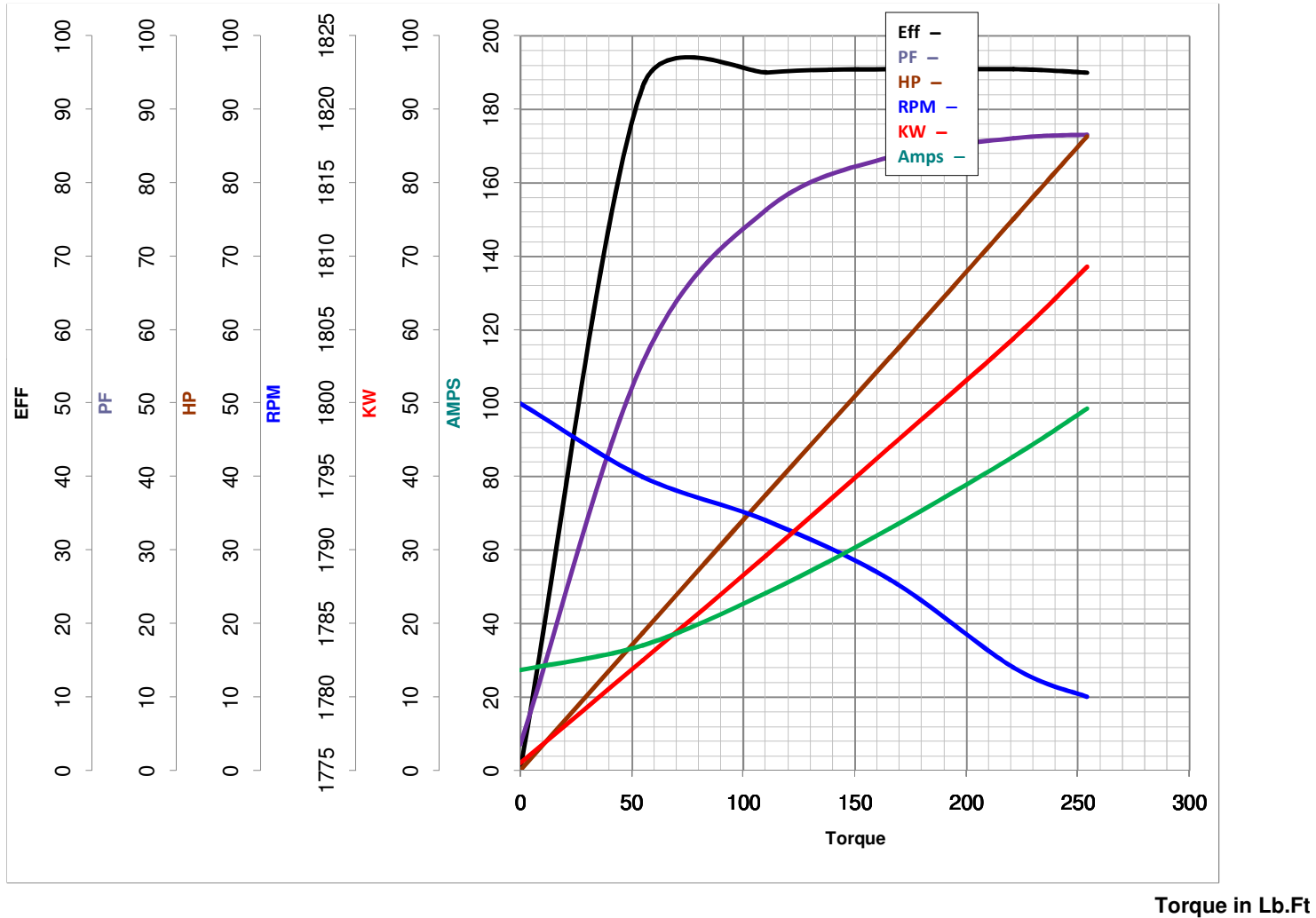

FL TORQUE 221 Lb.Ft
 BD TORQUE 586.0 Lb.Ft
 LR TORQUE 464 Lb.Ft

FL AMPS 171/85.5
 PU TORQUE 395.0 Lb.Ft
 LR AMPS 542

WINDING HE32254009-2 Prepared By FAREEDA

Date 5/4/2018