

# PRODUCT INFORMATION PACKET

**marathon**<sup>®</sup>  
Motors

Model No: 254TTDBD6008  
Catalog No: GT0561  
20,3600,DP,254JM,3/60/575  
JM



Regal and Marathon are trademarks of Regal Beloit Corporation or one of its affiliated companies.  
©2018 Regal Beloit Corporation, All Rights Reserved. MC017097E

**REGAL**<sup>®</sup>



### Nameplate Specifications

Output HP	<b>20 Hp</b>	Output KW	<b>14.9 kW</b>
Frequency	<b>60 Hz</b>	Voltage	<b>575 V</b>
Current	<b>19.2 A</b>	Speed	<b>3552 rpm</b>
Service Factor	<b>1.15</b>	Phase	<b>3</b>
Efficiency	<b>91 %</b>	Duty	<b>Continuous</b>
Insulation Class	<b>F</b>	Design Code	<b>B</b>
KVA Code	<b>F</b>	Frame	<b>254JM</b>
Enclosure	<b>Drip Proof</b>	Overload Protector	<b>No</b>
Ambient Temperature	<b>40 °C</b>	Drive End Bearing Size	<b>6309</b>
Opp Drive End Bearing Size	<b>6208</b>	UL	<b>Recognized</b>
CSA	<b>Y</b>	CE	<b>Y</b>
IP Code	<b>22</b>		

### Technical Specifications

Electrical Type	<b>Squirrel Cage Inverter Rated</b>	Starting Method	<b>Line Or Inverter</b>
Poles	<b>2</b>	Rotation	<b>Reversible</b>
Mounting	<b>Rigid base</b>	Motor Orientation	<b>Horizontal</b>
Drive End Bearing	<b>Ball</b>	Opp Drive End Bearing	<b>Ball</b>
Frame Material	<b>Rolled Steel</b>	Shaft Type	<b>JM</b>
Frame Length	<b>10.62 in</b>	Shaft Diameter	<b>1.249 in</b>
Shaft Extension	<b>5.5 in</b>	Assembly/Box Mounting	<b>F1/F2 Capable</b>
Outline Drawing	<b>SS620822-254</b>	Connection Diagram	<b>EE7300</b>

This is an uncontrolled document once printed or downloaded and is subject to change without notice. Date Created: 07/02/2018

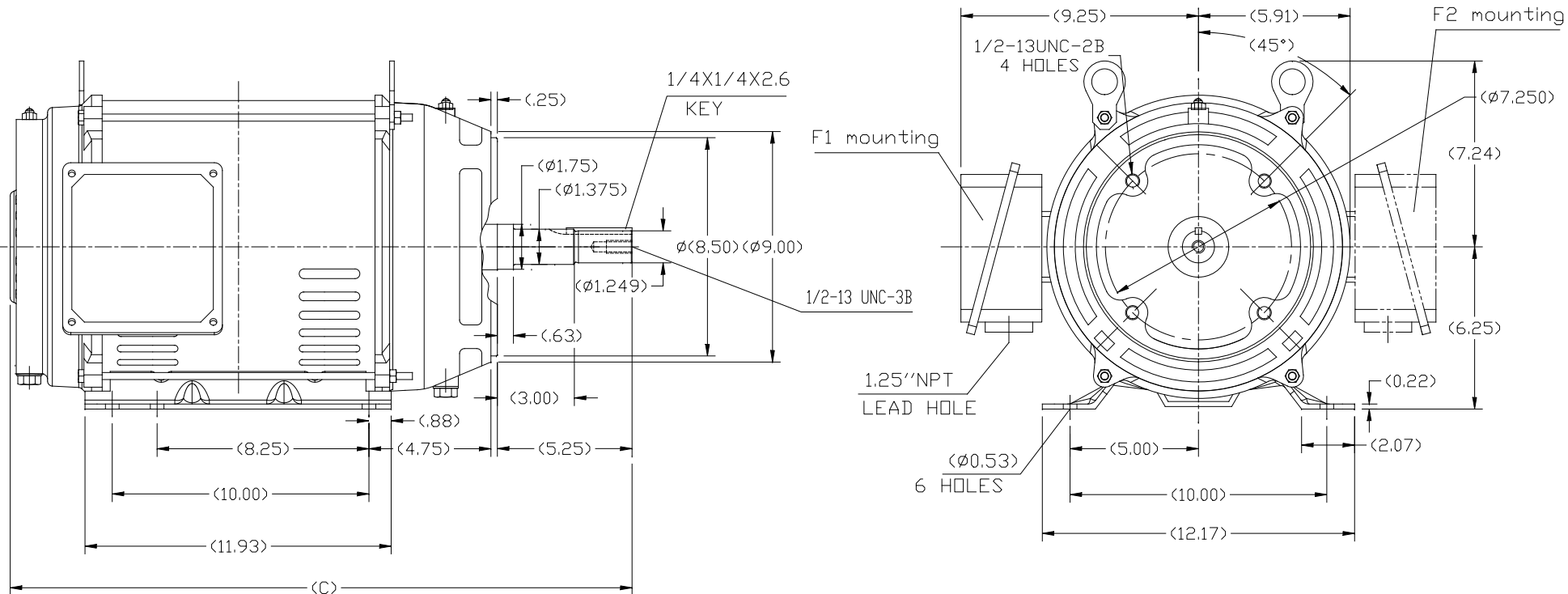

254T	24.41	YES
256T	25.99	YES
FRAME	C	F1/F2

		TOLERANCES UNLESS SPECIFIED		REGAL REGAL-BELOIT CORPORATION		DRAWN ZXW 17-04-2017	
		DEC.	INCHES			CHK WY 17-04-2017	
		.X	±.1			APPD ZYH 17-04-2017	
		.XX	±.03	TITLE		SCALE	
		.XXX	±.005	254/256T ODP-JM-ROLLED STEEL		REF	
		.XXXX	±.0005	MAT'L.		FMF REGAL-WUXI	
NO.	REVISION	BY & DATE	CHK	ANG	FINISH	PREV	
THIS DRAWING IN DESIGN AND DETAIL IS OUR PROPERTY AND MUST NOT BE USED EXCEPT IN CONNECTION WITH OUR WORK ALL RIGHTS OF DESIGN AND INVENTION ARE RESERVED THIS IS AN ELECTRONICALLY GENERATED DOCUMENT - DO NOT SCALE THIS PRINT				RFP	CAD FILE	SS620822	SIZE
				DIST			DRAWING NO.
							B
							SS620822
							REV.

**THREE PHASE - SINGLE VOLTAGE  
MOTOR - CONDUIT BOX @ 'A'**

**TO REVERSE ROTATION:  
INTERCHANGE ANY TWO  
LINE LEAD CONNECTIONS.**

**TERMINAL BLOCK WHEN SPECIFIED**



**VIEW OF TERMINAL END**

**IF MOTOR HAS  
6 LEADS**





A-9806 DECAL

**OPTIONAL CORD  
CONNECTION**

- L1 \_\_\_\_\_ WHITE
- L2 \_\_\_\_\_ RED
- L3 \_\_\_\_\_ BLACK

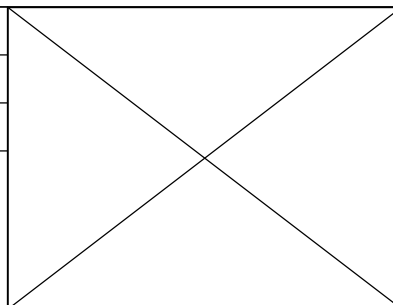
DRAWING REVISION AB	REVISION BY JJB	DATE 06-27-2017
ECO ECO-0125361	APPROVED BY TB	DATE 06-27-2017
ECO DESCRIPTION <b>UPDATED TO CURRENT STANDARDS</b>		
<small>COPYRIGHT REGAL BELOIT AMERICA, INC. ALL RIGHTS RESERVED.                  PROPRIETARY AND CONFIDENTIAL INFORMATION - THIS DOCUMENT IS THE PROPERTY OF                  REGAL BELOIT AMERICA, INC. ('OWNER') AND CONTAINS OWNER'S PROPRIETARY                  INFORMATION. ANY PERSON, CORPORATION OR OTHER FIRM RECEIVING IT IS DEEMED,                  BY RECEIVING IT, TO AGREE THAT IT, AND/OR ANY PART OF IT, SHALL NOT BE DISCLOSED                  TO ANY PERSON, CORPORATION OR OTHER ENTITY, DUPLICATED, AND/OR USED, EXCEPT                  AS EXPRESSLY APPROVED IN WRITING IN ADVANCE BY OWNER. THIS DOCUMENT SHALL                  BE RETURNED TO OWNER UPON REQUEST. IT MAY BE SUBJECT TO CERTAIN                  RESTRICTIONS UNDER APPLICABLE EXPORT CONTROL LAWS AND REGULATIONS.</small>		



DRAWN BY DA	 Regal Beloit America, Inc.
DATE 03-26-1993	
APPROVED BY TB	DESCRIPTION <b>CONNECTION DIAGRAM</b> EXTERNAL - SINGLE VOLTAGE - 3Ø MOTOR
DATE 03-26-1993	MATERIAL
REFERENCE	PROCESS/FINISH
THIRD ANGLE PROJECTION	SIZE <b>A</b>
	DRAWING NUMBER <b>EE7300</b>
	SHEET <b>1 OF 1</b>



**P.O. BOX 8003  
WAUSAU, WI 54401-8003  
PH. 715-675-3311**

**CERTIFICATION DATA SHEET**

**CUSTOMER:** CUSTOMER PO #:  
**ORDER #:** MODEL #: 254TTDDBD6008 AA  
**CONN. DIAGRAM:** EE7300 CUSTOMER PART #:  
**OUTLINE:** SS620822-254 MOUNTING: F1/F2 CAPABLE  
**WINDING #:** HE31602015 3

**TYPICAL MOTOR PERFORMANCE DATA**

HP	KW	SYNC. RPM	F.L. RPM	FRAME	ENCLOSURE	KVA CODE	DESIGN	
20	14.9	3600	3552	254JM	DP	F	B	
PH	HZ	VOLTS	AMPS	START TYPE	DUTY	INSL	S.F.	AMB°C
3	60	575	19.2	LINE OR INVERTER	CONTINUOUS	F7	1.15	40

<b>FULL LOAD EFF:</b>	91	<b>3/4 LOAD EFF:</b>	91	<b>1/2 LOAD EFF:</b>	90.6	<b>GTD. EFF</b>		<b>ELEC. TYPE</b>
<b>FULL LOAD PF:</b>	85.5	<b>3/4 LOAD PF:</b>	80.5	<b>1/2 LOAD PF:</b>	69.5	90.2		SQ CAGE INV RATED
<b>F.L. TORQUE LB-FT</b>	<b>LOCKED ROTOR AMPS</b>	<b>L.R. TORQUE LB-FT</b>	<b>176 %</b>	<b>B.D. TORQUE LB-FT</b>	<b>250 %</b>	<b>F.L. RISE°C</b>		
29.6	109.6	52	74			45		

<b>SOUND PRESSURE @ 3 FT. DBA</b>	<b>SOUND POWER DBA</b>	<b>ROTOR WK^2 LB-FT^2</b>	<b>MAX. WK^2 LB-FT^2</b>	<b>SAFE STALL TIME SEC.</b>	<b>STARTS / HOUR</b>	<b>APPROX. MOTOR WGT LBS.</b>
75	85	1.1	-	15	3	300

**\*\*\* SUPPLEMENTAL INFORMATION \*\*\***

DE BRACKET TYPE	ODE BRACKET TYPE	MOUNT TYPE	ORIENTATION	SEVERE DUTY	HAZARDOUS LOCATION	DRIP COVER	SCREENS	PAINT
C-FACE	STANDARD	RIGID	HORIZONTAL	FALSE	NONE	FALSE	NONE	BLUE (ENAMEL)

BEARINGS		GREASE	SHAFT TYPE	SPECIAL DE	SPECIAL ODE	SHAFT MATERIAL	FRAME MATERIAL
DE BALL	ODE BALL	POLYREX EM	JM	NONE	NONE	1045 HOT ROLLED (C-204)	ROLLED STEEL
6309	6208						

THERMO-PROTECTORS				THERMISTORS			SPACE HEATERS	
THERMOSTATS	PROTECTORS	WDG RTDS	BRG RTDS	NONE	FALSE	NONE	NONE	VOLTS
NONE	NOT	NONE	NONE					

<b>* INVERTER</b>	TORQUE: CONSTANT 2:1/VARIABLE 20:1
<b>N INV. HP SPEED RANGE:</b>	NONE
<b>O ENCODER:</b>	NONE
<b>T NONE</b>	NONE
<b>E NONE</b>	PPR
<b>S BRAKE:</b>	NONE
<b>* NONE</b>	P/N NONE
	NONE
	NONE
	FT-LB NONE V NONE HZ

**PREPARED BY:** Fareeda Dudekula  
**DATE:** 05/09/2018 08:17:32 AM  
**FORM 3531 REV.3 02/07/99**  
 \*\* Subject to change without notice.

**MARATHON ELECTRIC CORPORATION**

TYPICAL PERFORMANCE CURVE for AC MOTOR

Customer

Curve at

575

Volts

HP 20.00

PHASE 3

Model No 254TTDBD6008

60

HZ

VOLTS 575

20

HP

Catalog No GT0561

HZ 60

RPM 3552

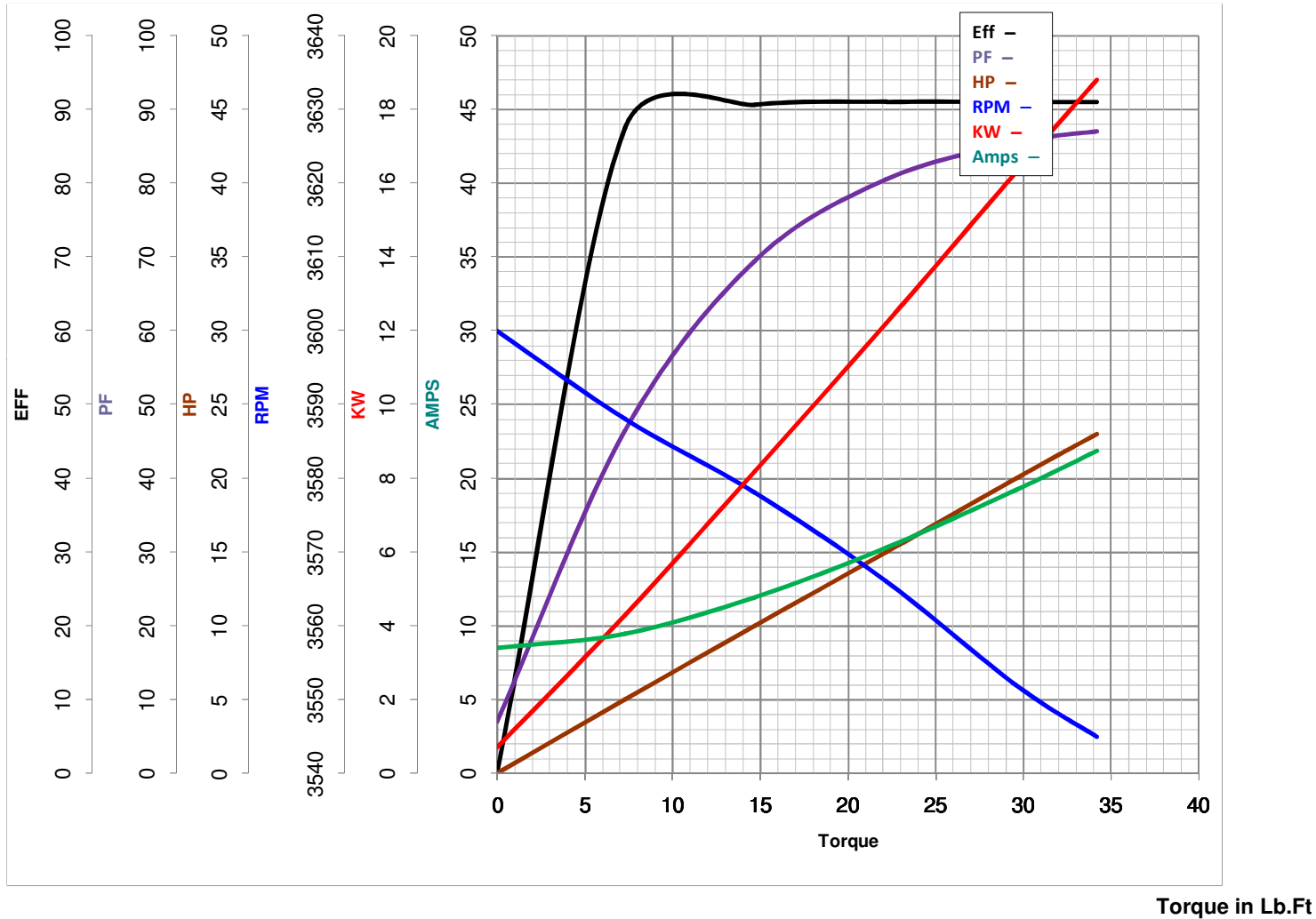

FL TORQUE 29.6 Lb.Ft  
 BD TORQUE 74.0 Lb.Ft  
 LR TORQUE 52 Lb.Ft

FL AMPS 19.2  
 PU TORQUE 44.0 Lb.Ft  
 LR AMPS 109.6

WINDING HE31602015-3 Prepared By FAREEDA

Date 5/9/2018