

# PRODUCT INFORMATION PACKET

**marathon**<sup>®</sup>  
Motors

Model No: 286TTDBD6082  
Catalog No: GT0463  
20,1200,DP,286JM,3/60/230/460  
JM



Regal and Marathon are trademarks of Regal Beloit Corporation or one of its affiliated companies.  
©2018 Regal Beloit Corporation, All Rights Reserved. MC017097E

**REGAL**<sup>®</sup>



### Nameplate Specifications

Output HP	<b>20 Hp</b>	Output KW	<b>14.9 kW</b>
Frequency	<b>60 Hz</b>	Voltage	<b>230/460 V</b>
Current	<b>52.5/26.3 A</b>	Speed	<b>1182 rpm</b>
Service Factor	<b>1.15</b>	Phase	<b>3</b>
Efficiency	<b>92.4 %</b>	Duty	<b>Continuous</b>
Insulation Class	<b>F</b>	Design Code	<b>B</b>
KVA Code	<b>F</b>	Frame	<b>286JMV</b>
Enclosure	<b>Drip Proof</b>	Overload Protector	<b>No</b>
Ambient Temperature	<b>40 °C</b>	Drive End Bearing Size	<b>6311</b>
Opp Drive End Bearing Size	<b>6211</b>	UL	<b>Recognized</b>
CSA	<b>Y</b>	CE	<b>Y</b>
IP Code	<b>22</b>		

### Technical Specifications

Electrical Type	<b>Squirrel Cage Inverter Rated</b>	Starting Method	<b>Wye Start Delta Run Or Inverter</b>
Poles	<b>6</b>	Rotation	<b>Reversible</b>
Mounting	<b>Rigid base</b>	Motor Orientation	<b>Horizontal Or Shaft Down</b>
Drive End Bearing	<b>Ball</b>	Opp Drive End Bearing	<b>Ball</b>
Frame Material	<b>Rolled Steel</b>	Shaft Type	<b>JM</b>
Frame Length	<b>13.97 in</b>	Shaft Diameter	<b>1.249 in</b>
Shaft Extension	<b>5.25 in</b>	Assembly/Box Mounting	<b>F1/F2 Capable</b>
Outline Drawing	<b>SS620823-286</b>	Connection Diagram	<b>EE7308AA</b>

This is an uncontrolled document once printed or downloaded and is subject to change without notice. Date Created: 07/02/2018

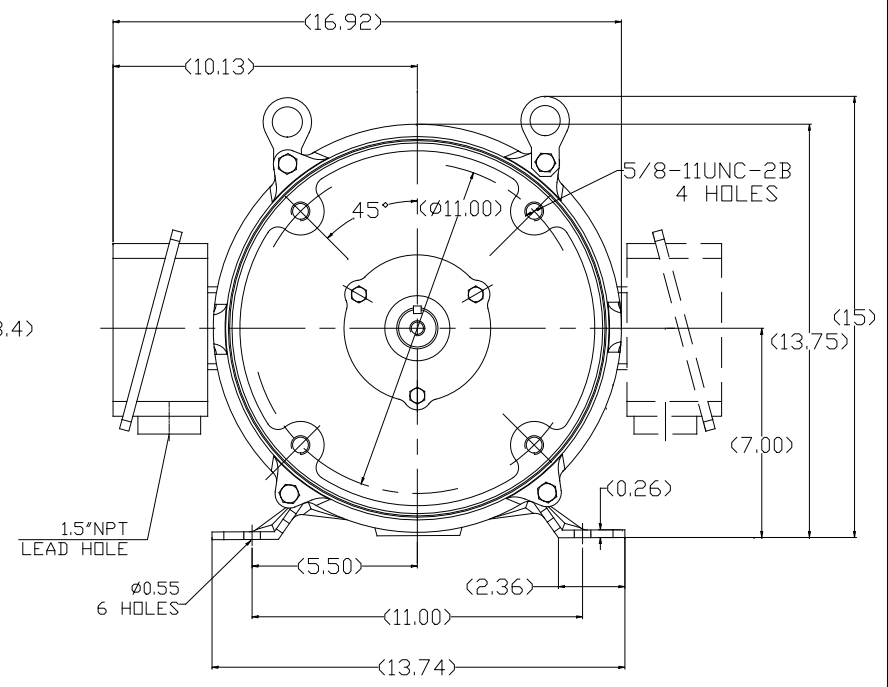
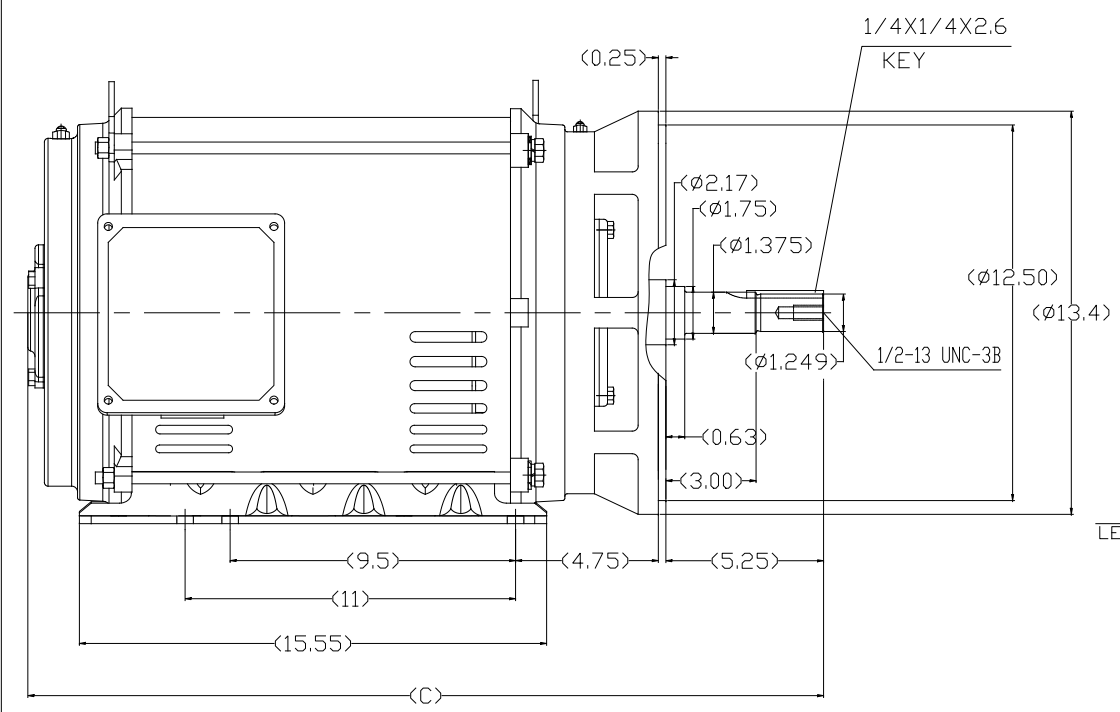

284T	26.58	YES
286T	27.09	YES
FRAME	C	F1/F2

TOLERANCES UNLESS SPECIFIED		 REGAL-BELOIT CORPORATION TITLE: 284/286T-ODP-JM-ROLLED STEEL MAT'L. FINISH	DRAWN ZXW 17-04-2017											
DEC.	INCHES		CHK	WY 17-04-2017										
.X	±.1		APPD	ZYH 17-04-2017										
.XX	±.03		SCALE	1:1										
.XXX	±.005		REF											
.XXXX	±.0005	FMF												
NO.	REVISION	BY & DATE	CHK	ANG	±1/2°	FINISH	PREV							
THIS DRAWING IN DESIGN AND DETAIL IS OUR PROPERTY AND MUST NOT BE USED EXCEPT IN CONNECTION WITH OUR WORK. ALL RIGHTS OF DESIGN AND INVENTION ARE RESERVED. THIS IS AN ELECTRONICALLY GENERATED DOCUMENT - DO NOT SCALE THIS PRINT.							RFP	CAD FILE	SS620823	SIZE	DRAWING NO.	PAGE	OF	REV.
							DIST			B	SS620823			

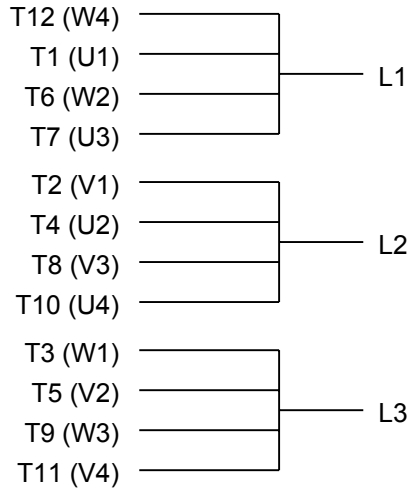

### LOW VOLTAGE

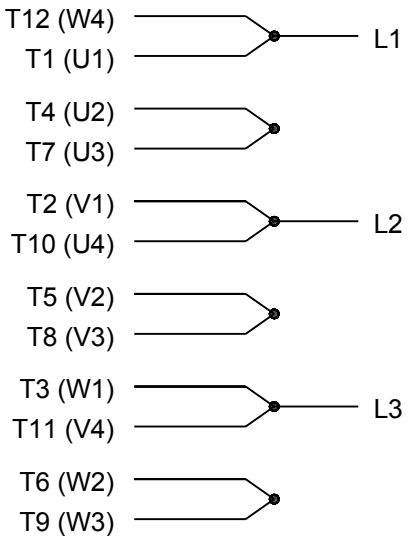

### HIGH VOLTAGE



DRAWING REVISION <b>K</b>	REVISION BY <b>AJW</b>	DATE <b>07-17-2015</b>
ECO <b>ECO-0081632</b>	APPROVED BY <b>T. VUE</b>	DATE <b>07-17-2015</b>
ECO DESCRIPTION <b>REV'D IEC MARKINGS PER IEC 60034-8</b>		
COPYRIGHT REGAL BELOIT AMERICA, INC. ALL RIGHTS RESERVED. PROPRIETARY AND CONFIDENTIAL INFORMATION - THIS DOCUMENT IS THE PROPERTY OF REGAL BELOIT AMERICA, INC. ("OWNER") AND CONTAINS OWNER'S PROPRIETARY INFORMATION. ANY PERSON, CORPORATION OR OTHER FIRM RECEIVING IT IS DEEMED, BY RECEIVING IT, TO AGREE THAT IT, AND/OR ANY PART OF IT, SHALL NOT BE DISCLOSED TO ANY PERSON, CORPORATION OR OTHER ENTITY, DUPLICATED, AND/OR USED, EXCEPT AS EXPRESSLY APPROVED IN WRITING IN ADVANCE BY OWNER. THIS DOCUMENT SHALL BE RETURNED TO OWNER UPON REQUEST. IT MAY BE SUBJECT TO CERTAIN RESTRICTIONS UNDER APPLICABLE EXPORT CONTROL LAWS AND REGULATIONS.		



DRAWN BY <b>LZ</b>	<b>Regal Beloit America, Inc.</b>	
DATE <b>01-12-1994</b>		
APPROVED BY <b>GK</b>	DESCRIPTION <b>CONN DIAGRAM-EXTERNAL</b> <b>3Ø-2/1 DELTA-12 LEADS</b>	
DATE <b>01-14-1994</b>		
REFERENCE	MATERIAL	PROCESS/FINISH
THIRD ANGLE PROJECTION	SIZE <b>A</b>	DRAWING NUMBER <b>EE7308AA</b>
		SHEET <b>1 OF 1</b>



**P.O. BOX 8003  
WAUSAU, WI 54401-8003  
PH. 715-675-3311**

**CERTIFICATION DATA SHEET**

**CUSTOMER:**  
**ORDER #:**  
**CONN. DIAGRAM:**  
**OUTLINE:**  
**WINDING #:**

**CUSTOMER DATA SHEET**  
**CUSTOMER**  
**PO #:**  
**MODEL #:**  
**CUSTOMER PART**  
**#:**  
**MOUNTING:**

**TYPICAL MOTOR PERFORMANCE DATA**

HP	KW	SYNC. RPM	F.L. RPM	FRAME	ENCLOSURE	KVA CODE	DESIGN	
208.15	14.9&11.2	1200	1182&985	286JMV	DP	F	B	
PH	Hz	VOLTS	AMPS	START TYPE	DUTY	INSL	S.F.	AMB°C
3	60/50	230/460&190/380	52.5/26.3&48.5/24.3	Y START D RUN OR INV	CONTINUOUS	F7	1.15/1.15	40

<b>FULL LOAD EFF:</b>	92.4&91.7	<b>3/4 LOAD EFF:</b>	92.4	<b>1/2 LOAD EFF:</b>	91.7	<b>GTD. EFF</b>	91.7	<b>ELEC. TYPE</b>
<b>FULL LOAD PF:</b>	77&77.5	<b>3/4 LOAD PF:</b>	71	<b>1/2 LOAD PF:</b>	59.5	91.7	SQ CAGE INV RATED	

F.L. TORQUE	LOCKED ROTOR AMPS	L.R. TORQUE	B.D. TORQUE	F.L. RISE°C
89 LB-FT	276 / 138	150 LB-FT	169 %	217 LB-FT 244 %
				50

SOUND PRESSURE @ 3 FT.	SOUND POWER	ROTOR WK^2	MAX. WK^2	SAFE STALL TIME	STARTS / HOUR	APPROX. MOTOR WGT
65 DBA	75 DBA	6 LB-FT^2	- LB-FT^2	- SEC.	2	420 LBS.

**\*\*\* SUPPLEMENTAL INFORMATION \*\*\***

DE BRACKET TYPE	ODE BRACKET TYPE	MOUNT TYPE	ORIENTATION	SEVERE DUTY	HAZARDOUS LOCATION	DRIP COVER	SCREENS	PAINT
C-FACE	STANDARD	RIGID	HORIZONTAL OR SHAFT DOWN	FALSE	NONE	FALSE	NONE	BLUE (ENAMEL)

BEARINGS		GREASE	SHAFT TYPE	SPECIAL DE	SPECIAL ODE	SHAFT MATERIAL	FRAME MATERIAL
DE	ODE						
BALL	BALL	POLYREX EM	JM	NONE	NONE	1045 HOT ROLLED (C-204)	ROLLED STEEL
6311	6211						

THERMO-PROTECTORS				THERMISTORS	CONTROL	SPACE HEATERS
<b>THERMOSTATS</b>	<b>PROTECTORS</b>	<b>WDG RTDS</b>	<b>BRG RTDS</b>	NONE	FALSE	NONE
NONE	NOT	NONE	NONE			

**INVERTER TORQUE:** VARIABLE 20:1  
**INV. HP SPEED RANGE:** NONE

<b>ENCODER:</b>	NONE
NONE	NONE
NONE	PPR

<b>BRAKE:</b>	NONE	NONE
NONE	P/N	NONE
NONE	NONE	NONE
NONE	FT-LB	NONE V NONE HZ

\*  
 N  
 O  
 T  
 E  
 S

\*

**PREPARED BY:** Anusha Muthyala

**DATE:** 05/04/2018 12:40:24 AM

**FORM:** 3531 REV.3 02/07/99

**\*\* Subject to change without notice.**

**MARATHON ELECTRIC CORPORATION**

TYPICAL PERFORMANCE CURVE for AC MOTOR

Customer \_\_\_\_\_ Curve at 460 Volts HP 20&15 PHASE 3  
 Model No 286TTDBD6082 60 HZ  
20 HP VOLTS 230/460&190/380  
 Catalog No GT0463 HZ 60&50 RPM 1182&985

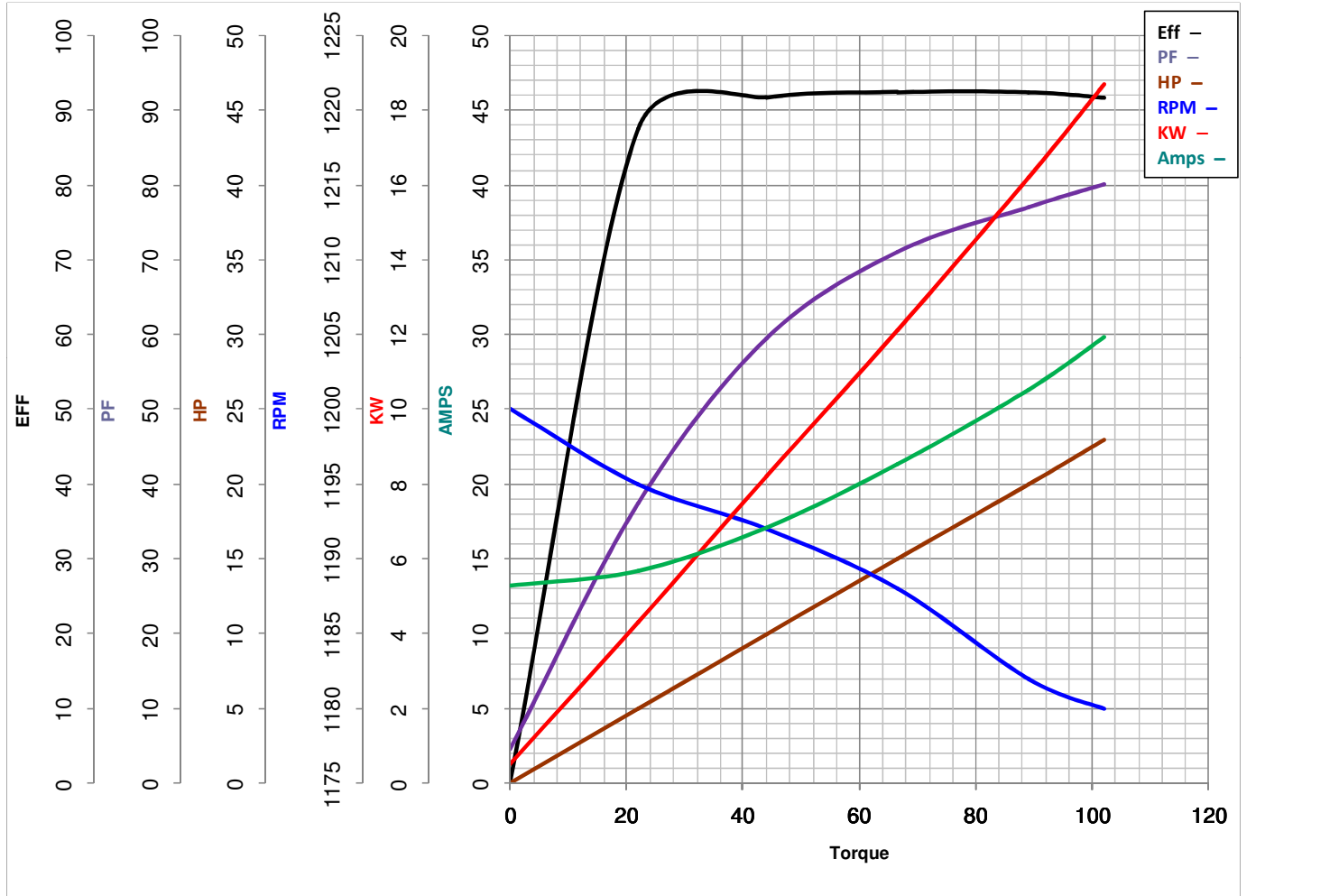

FL TORQUE 89 Lb.Ft  
 BD TORQUE 217.0 Lb.Ft  
 LR TORQUE 150 Lb.Ft

FL AMPS 52.5/26.3  
 PU TORQUE 128.0 Lb.Ft  
 LR AMPS 138

WINDING HE31806007-2 Prepared By ANUSHA M Date 5/4/2018