

PRODUCT INFORMATION PACKET

Model No: 365TTFC16591

Catalog No: E643B

50 HP, Severe Duty Motors, 3 phase, 1200 RPM, 460 V, 365T Frame, TEFC

Other Severe Duty Motors



Nameplate Specifications

Output HP	50 Hp	Output KW	37.0 kW
Frequency	60 Hz	Voltage	460 V
Current	60.5 A	Speed	1188 rpm
Service Factor	1.15	Phase	3
Efficiency	94.1 %	Power Factor	82.5
Duty	Continuous	Insulation Class	H
Design Code	B	KVA Code	G
Frame	365T	Enclosure	Totally Enclosed Fan Cooled
Thermal Protection	No	Ambient Temperature	40 °C
Drive End Bearing Size	6313	Opp Drive End Bearing Size	6213
UL	Listed	CSA	Y
CE	Y	IP Code	55
Hazardous Location	DIVISION 2 T2B		

Technical Specifications

Electrical Type	Squirrel Cage Inverter Rated	Starting Method	Line Or Inverter
Poles	6	Rotation	Selective Clockwise
Resistance Main	.1329 Ohms	Mounting	Rigid Base
Motor Orientation	Horizontal	Drive End Bearing	Ball
Opp Drive End Bearing	Ball	Frame Material	Cast Iron
Shaft Type	T	Shaft Diameter	2.375 in
Assembly/Box Mounting	F1/F2 CAPABLE		
Connection Drawing	EE7300U	Outline Drawing	SS557662-365T

This is an uncontrolled document once printed or downloaded and is subject to change without notice. Date Created:20/08/2020

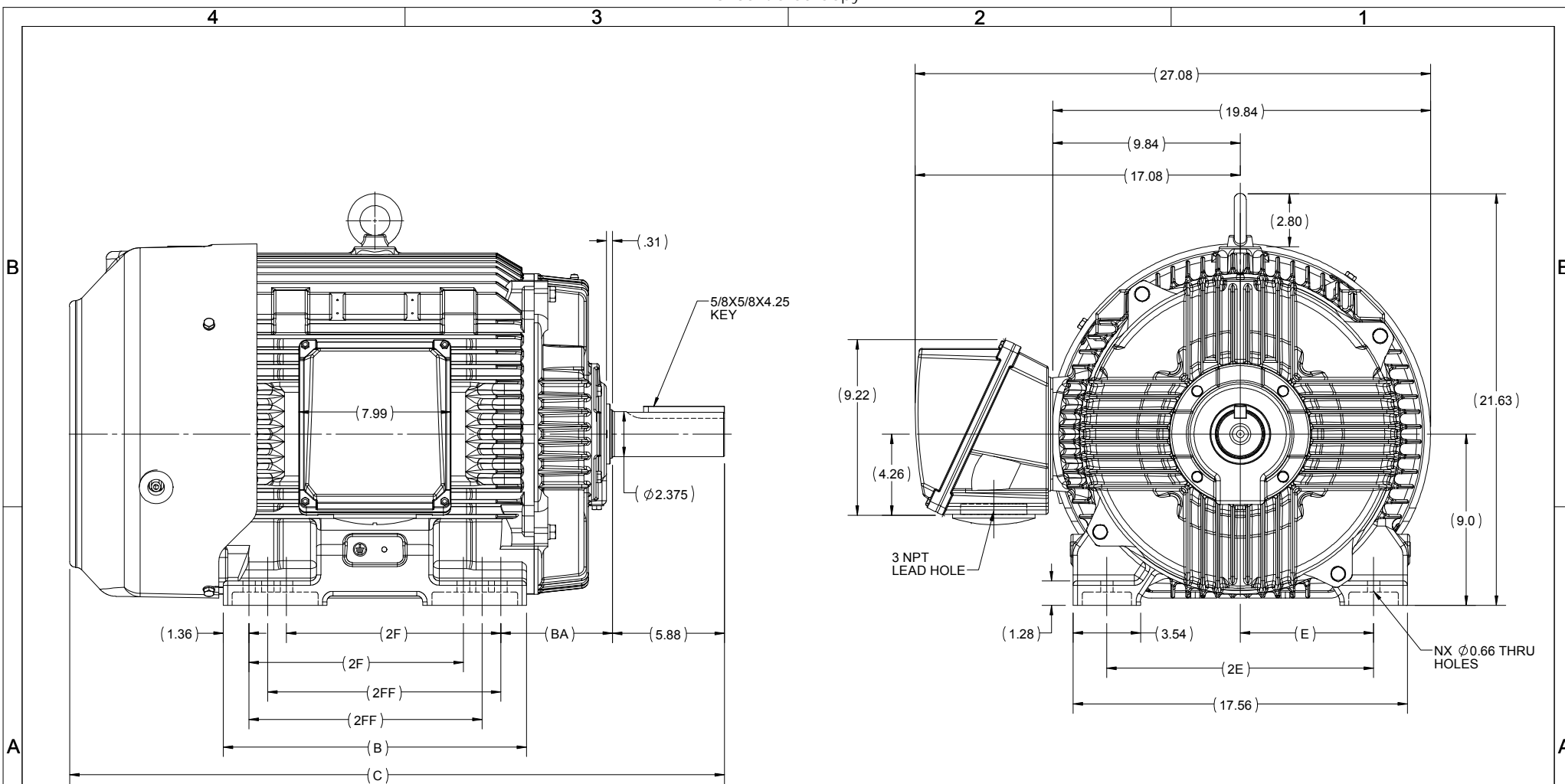

364/365T	15.94	34.40	12.25	11.25	5.88	7.00	14.00	12	F1 OR F2
364T	14.96	33.42	11.25	-				8	F1 OR F2
FRAME	B	C	2FF	2F	BA	E	2E	N	MOUNTING

DRAWING REVISION B	REVISION BY BISWA	DATE 25/01/2018
ECO ECO-0160791	APPROVED BY SBD	DATE 25/01/2018
ECO DESCRIPTION DRAWING UPDATED		
<small>COPYRIGHT REGAL BELOIT AMERICA, INC. ALL RIGHTS RESERVED. PROPRIETARY AND CONFIDENTIAL INFORMATION - THIS DOCUMENT IS THE PROPERTY OF REGAL BELOIT AMERICA, INC. ("OWNER") AND CONTAINS OWNER'S PROPRIETARY INFORMATION. ANY PERSON, CORPORATION OR OTHER FIRM RECEIVING IT IS DEEMED, BY RECEIVING IT, TO AGREE THAT IT, AND/OR ANY PART OF IT, SHALL NOT BE DISCLOSED TO ANY PERSON, CORPORATION OR OTHER ENTITY, DUPLICATED, AND/OR USED, EXCEPT AS EXPRESSLY APPROVED IN WRITING IN ADVANCE BY OWNER. THIS DOCUMENT SHALL BE RETURNED TO OWNER UPON REQUEST. IT MAY BE SUBJECT TO CERTAIN RESTRICTIONS UNDER APPLICABLE EXPORT CONTROL LAWS AND REGULATIONS.</small>		

DRAWN BY BISWA	 Regal Beloit America, Inc.
DATE 01/10/2018	
APPROVED BY SBD	DESCRIPTION OUTLINE 364/365T FR-NEMA-SD & IEEEE841
DATE 01/10/2018	MATERIAL
REFERENCE	PROCESS/FINISH
THIRD ANGLE PROJECTION	SIZE B
	DRAWING NUMBER SS557662
	SHEET 1 OF 1

4 3 2 1

IF MOTOR HAS 9 LEADS



IF MOTOR HAS 6 LEADS



A-9806 DECAL IF CALLED FOR

IF MOTOR HAS 12 LEADS

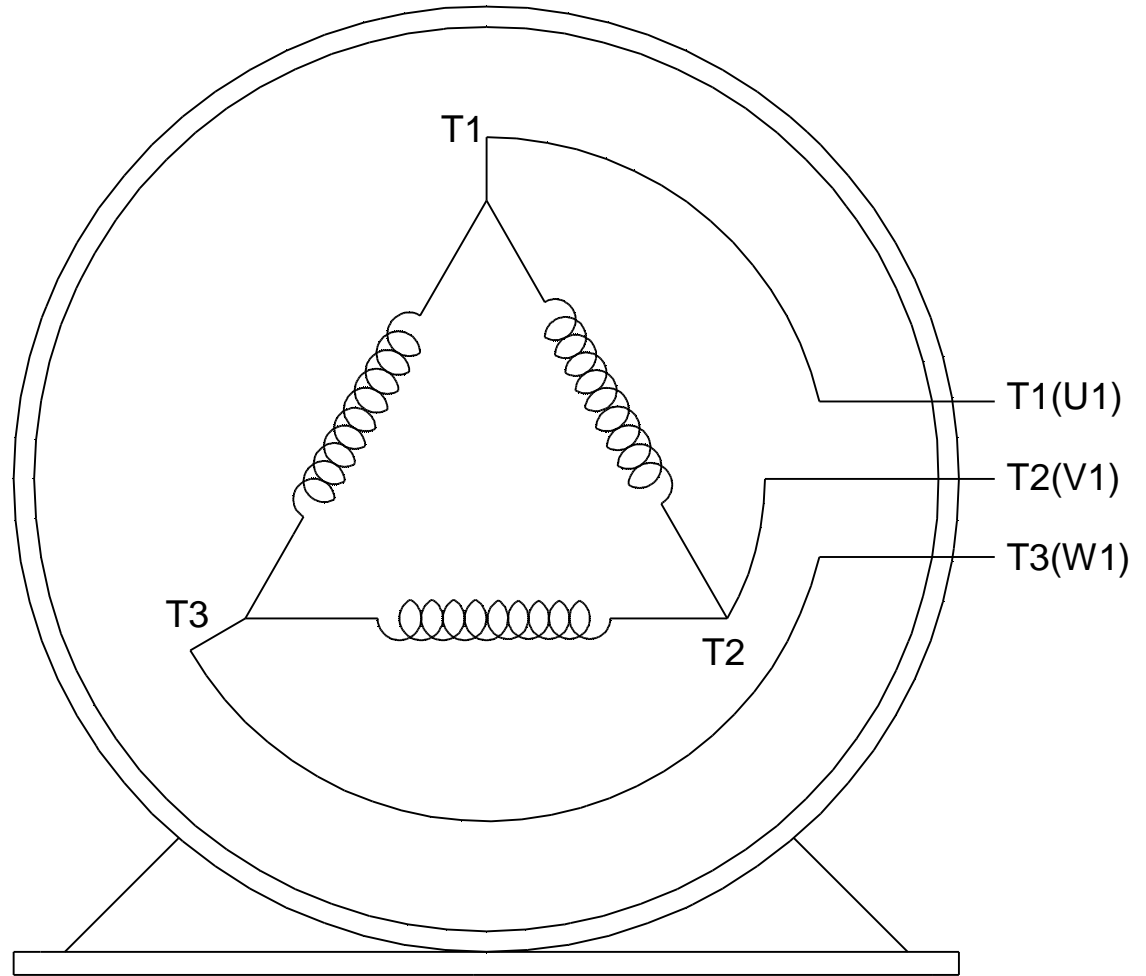

VIEW OF TERMINAL END

DRAWING REVISION L	REVISION BY AJW	DATE 05-04-2015	TOLERANCES UNLESS OTHERWISE SPECIFIED:	DRAWN BY DRS	Regal Beloit America, Inc.																			
ECO ECO-0077067	APPROVED BY EWH	DATE 05-05-2015	<table style="font-size: small; border-collapse: collapse;"> <tr> <td><u>DEC.</u></td> <td><u>INCH</u></td> <td><u>mm</u></td> <td><u>ANGLE</u></td> </tr> <tr> <td>.X</td> <td>±0.1</td> <td>[±2.5]</td> <td>±7' 30"</td> </tr> <tr> <td>.XX</td> <td>±0.02</td> <td>[±0.51]</td> <td></td> </tr> <tr> <td>.XXX</td> <td>±0.005</td> <td>[±0.127]</td> <td></td> </tr> <tr> <td>.XXXX</td> <td>±0.0005</td> <td>[±0.0127]</td> <td></td> </tr> </table>	<u>DEC.</u>		<u>INCH</u>	<u>mm</u>	<u>ANGLE</u>	.X	±0.1	[±2.5]	±7' 30"	.XX	±0.02	[±0.51]		.XXX	±0.005	[±0.127]		.XXXX	±0.0005	[±0.0127]	
<u>DEC.</u>	<u>INCH</u>	<u>mm</u>	<u>ANGLE</u>																					
.X	±0.1	[±2.5]	±7' 30"																					
.XX	±0.02	[±0.51]																						
.XXX	±0.005	[±0.127]																						
.XXXX	±0.0005	[±0.0127]																						
ECO DESCRIPTION UPDATED TO SOLIDWORKS <small>COPYRIGHT REGAL BELOIT AMERICA, INC. ALL RIGHTS RESERVED. PROPRIETARY AND CONFIDENTIAL INFORMATION - THIS DOCUMENT IS THE PROPERTY OF REGAL BELOIT AMERICA, INC. ("OWNER") AND CONTAINS OWNER'S PROPRIETARY INFORMATION. ANY PERSON, CORPORATION OR OTHER FIRM RECEIVING IT IS DEEMED, BY RECEIVING IT, TO AGREE THAT IT, AND/OR ANY PART OF IT, SHALL NOT BE DISCLOSED TO ANY PERSON, CORPORATION OR OTHER ENTITY, DUPLICATED, AND/OR USED, EXCEPT AS EXPRESSLY APPROVED IN WRITING IN ADVANCE BY OWNER. THIS DOCUMENT SHALL BE RETURNED TO OWNER UPON REQUEST. IT MAY BE SUBJECT TO CERTAIN RESTRICTIONS UNDER APPLICABLE EXPORT CONTROL LAWS AND REGULATIONS.</small>			REMOVE BURRS & BREAK SHARP EDGES: .003/.015 [.076/.381] X 45° CORNER FILLETS: R.02 [.51] MACHINED SURFACES: 200 $\sqrt{\text{INCH}}$ 5.1 $\sqrt{\text{mm}}$ mm SHOWN IN [BRACKETS]	APPROVED BY GK	DESCRIPTION <h3 style="text-align: center;">CONN DIAGRAM-EXTERNAL</h3> 3Ø SINDLE VOLTAGE																			
				DATE 09-30-1996		MATERIAL	PROCESS/FINISH																	
			THIRD ANGLE PROJECTION	SIZE A	DRAWING NUMBER EE7300U	SHEET 1 OF 1																		



DATA VOLTS: 460

CERTIFICATION DATA SHEET

CONN. DIAGRAM: EE7300U
 OUTLINE: SS557662-365T
 WINDING: HE32256004 NONE 1

MODEL #: 365TFC016591
 CAT #: E643B
 MOUNTING: F1/F2 CAPABLE

TYPICAL MOTOR PERFORMANCE DATA

HP	KW	SYNC RPM	FL RPM	FRAME	ENCLOSURE	TYPE	KVA CODE	DESIGN
50	37	1200	1188	365T	TEFC	TFC	G	B

PH	HZ	VOLTS	AMPS	START TYPE	DUTY	INSL	S.F.	AMB (°C)	ELEV.(ft)
3	60	460	60.5	LINE OR INVERTER	CONT	F	1.15	40	3300

F.L. EFF	94.1	3/4 LD EFF	94.1	1/2 LD EFF	93.6	GTD EFF	ELECT. TYPE
F.L. PF	82.5	3/4 LD PF	78.0	1/2 LD PF	68.5	93.6	SQ CAGE INV RATED

F.L. TORQUE	LR AMPS @ 460 V	L.R. TORQUE	B.D. TORQUE	F.L. RISE (°C)
221 LB-FT	362	398 LB-FT 180%	620 LB-FT 281%	65

SOUND PRESSURE @	SOUND	ROTOR WK ¹	MAX. LOAD WK ²	SAFE STALL TIME	STARTS/HOUR	APROX.	MOTOR
68 dBA	77 dBA	27.5 LB-FT ²	900 LB-FT ²	20 SEC.	2	987	LB.

*** SUPPLEMENTAL INFORMATION ***

DE BRACKET TYPE	ODE BRACKET TYPE	MOUNT TYPE	MOTOR ORIENTATION	SEVERE DUTY	HAZARDOUS LOCATION	DRIP COVER	SCREENS	PAINT
STANDARD	STANDARD	RIGID	HORIZONTAL	PREMIUM SEVERE DUTY	DIVISION 2 T2B	NO	NONE	BLUE (EPOXY)

BEARINGS		GREASE	SHAFT TYPE	SPECIAL DE	SPECIAL ODE	SHAFT	MATERIAL	FRAME MATERIAL
DE	ODE	POLYREX EM	T	NONE	NONE	1045 HOT ROLLED (C-204)		CAST IRON
BALL	BALL							
6313	6213							

THERMOSTATS	PROTECTORS	WDG RTD's	BRG RTD's	THERMISTORS	CONTROL	SPACE	HEATERS
NONE	NOT	NONE	NONE	NONE	FALSE		NA

R1 (ohms/ph)	R2 (ohms/ph)	X1 (ohms/ph)	X2 (ohms/ph)	Xm (ohms/ph)	VIBRATION (in/sec)
0.083	0.05	0.34	0.629	10.546	0.080

If Inverter equals NONE, contact factory for further information

* N O T E S *		INVERTER TORQUE: CONSTANT 2:1
		INV. HP SPEED RANGE: NONE
		ENCODER: NONE
		NONE NONE NONE PPR
		BRAKE: NONE

PREPARED BY: ANUSHA M
 DATE: 3/10/2020

NONE NONE NONE
 FT-LB: NA
 VOLTAGE: NONE HZ:

FORM: 3531 REV_4 2/27/06
 ** Subject to change without notice.

