

# PRODUCT INFORMATION PACKET

**marathon®**  
Motors

Model No: 324TSTFCD6501

Catalog No: E609A

40 HP, Severe Duty Motors, 3 phase, 3600 RPM, 460 V, 324TS Frame, TEFC  
Other Severe Duty Motors



Regal and Marathon are trademarks of Regal Beloit Corporation or one of its affiliated companies.  
©2020 Regal Beloit Corporation, All Rights Reserved. MC017097E

**REGAL**



### Nameplate Specifications

Output HP	<b>40 Hp</b>	Output KW	<b>30.0 kW</b>
Frequency	<b>60 Hz</b>	Voltage	<b>460 V</b>
Current	<b>46.0 A</b>	Speed	<b>3565 rpm</b>
Service Factor	<b>1.15</b>	Phase	<b>3</b>
Efficiency	<b>92.4 %</b>	Power Factor	<b>88</b>
Duty	<b>Continuous</b>	Insulation Class	<b>H</b>
Design Code	<b>B</b>	KVA Code	<b>G</b>
Frame	<b>324TS</b>	Enclosure	<b>Totally Enclosed Fan Cooled</b>
Thermal Protection	<b>No</b>	Ambient Temperature	<b>40 °C</b>
Drive End Bearing Size	<b>6312</b>	Opp Drive End Bearing Size	<b>6212</b>
UL	<b>Listed</b>	CSA	<b>Y</b>
CE	<b>Y</b>	IP Code	<b>55</b>
Hazardous Location	<b>DIVISION 2 T2B</b>		

### Technical Specifications

Electrical Type	<b>Squirrel Cage Inverter Rated</b>	Starting Method	<b>Line Or Inverter</b>
Poles	<b>2</b>	Rotation	<b>Selective Clockwise</b>
Resistance Main	<b>.1736 Ohms</b>	Mounting	<b>Rigid Base</b>
Motor Orientation	<b>Horizontal</b>	Drive End Bearing	<b>Ball</b>
Opp Drive End Bearing	<b>Ball</b>	Frame Material	<b>Cast Iron</b>
Shaft Type	<b>TS</b>	Shaft Diameter	<b>1.875 in</b>
Assembly/Box Mounting	<b>F1/F2 CAPABLE</b>		
Outline Drawing	<b>SS312940</b>	Connection Drawing	<b>EE7300U</b>

This is an uncontrolled document once printed or downloaded and is subject to change without notice. Date Created:20/08/2020

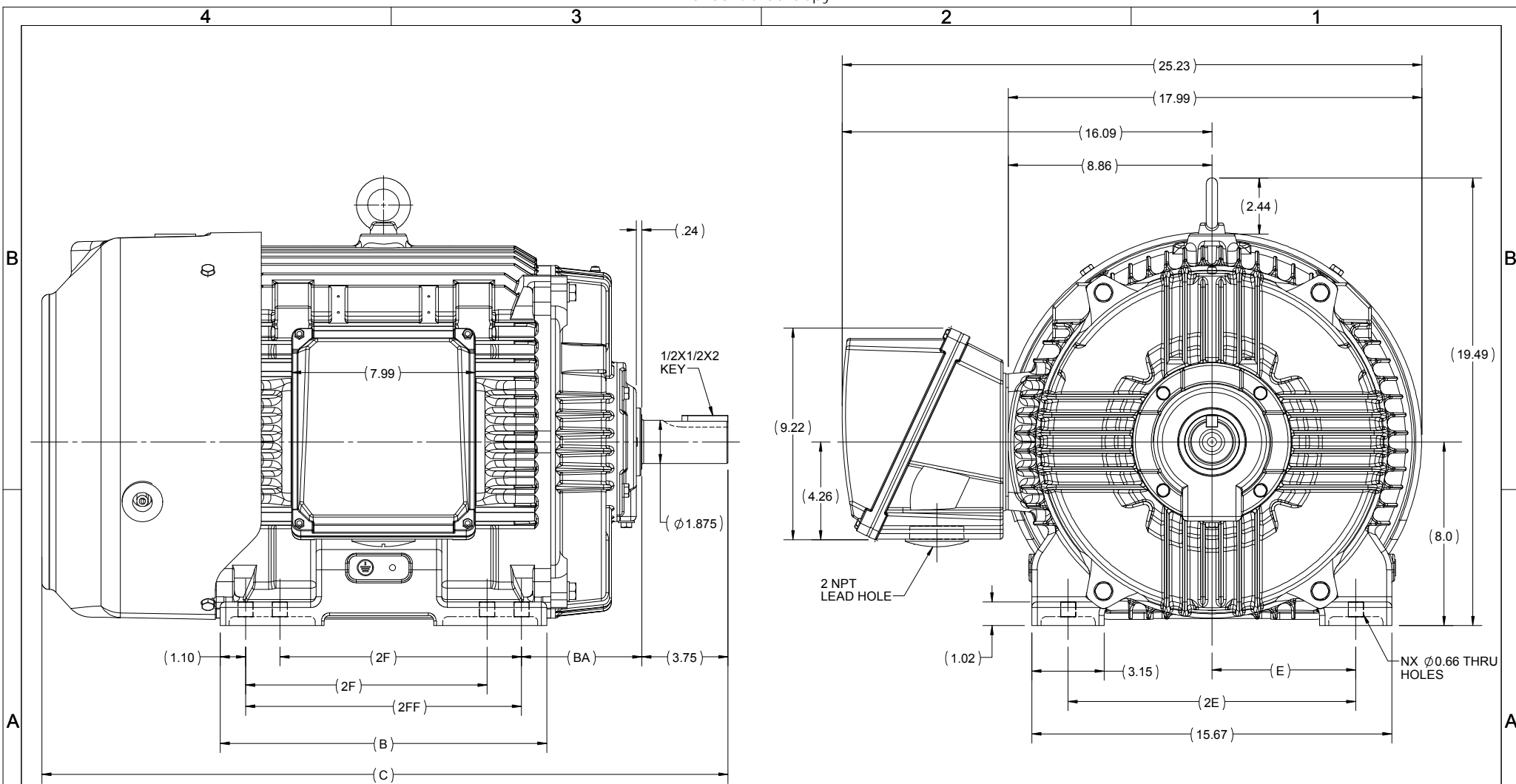

324/326TS	14.21	29.85	12.00	10.50					8	F1 OR F2
324TS	12.71	28.35	10.50	-	5.25	6.25	12.50		4	F1 OR F2
FRAME	B	C	2FF	2F	BA	E	2E	N		MOUNTING

DRAWING REVISION C	REVISION BY BISWA	DATE 25/03/2019
ECO ECO-0163961	APPROVED BY SBD	DATE 25/03/2019
ECO DESCRIPTION DRAWING UPDATED		
<small>COPYRIGHT REGAL BELOIT AMERICA, INC. ALL RIGHTS RESERVED.          PROPRIETARY AND CONFIDENTIAL INFORMATION - THIS DOCUMENT IS THE PROPERTY OF          REGAL BELOIT AMERICA, INC. (OWNER) AND CONTAINS OWNER'S PROPRIETARY          INFORMATION. ANY PERSON, CORPORATION OR OTHER FIRM RECEIVING IT IS DEEMED,          BY RECEIVING IT, TO AGREE THAT IT, AND/OR ANY PART OF IT, SHALL NOT BE DISCLOSED          TO ANY PERSON, CORPORATION OR OTHER ENTITY, DUPLICATED, AND/OR USED, EXCEPT          AS EXPRESSLY APPROVED IN WRITING IN ADVANCE BY OWNER. THIS DOCUMENT SHALL          BE RETURNED TO OWNER UPON REQUEST. IT MAY BE SUBJECT TO CERTAIN          RESTRICTIONS UNDER APPLICABLE EXPORT CONTROL LAWS AND REGULATIONS.</small>		

DRAWN BY BISWA	 Regal Beloit America, Inc.
DATE 24/10/2018	
APPROVED BY SBD	DESCRIPTION <b>OUTLINE</b> 320TS FR-NEMA-SD & IEEE841
DATE 24/10/2018	MATERIAL
REFERENCE	PROCESS/FINISH
THIRD ANGLE PROJECTION	SIZE B
	DRAWING NUMBER <b>SS312940</b>
	SHEET 1 OF 1

### IF MOTOR HAS 9 LEADS



### IF MOTOR HAS 6 LEADS



A-9806 DECAL IF CALLED FOR

### IF MOTOR HAS 12 LEADS



## VIEW OF TERMINAL END

DRAWING REVISION <b>L</b>	REVISION BY <b>AJW</b>	DATE <b>05-04-2015</b>	TOLERANCES UNLESS OTHERWISE SPECIFIED:	DRAWN BY <b>DRS</b>	<b>Regal Beloit America, Inc.</b>																					
ECO <b>ECO-0077067</b>	APPROVED BY <b>EWH</b>	DATE <b>05-05-2015</b>	<table style="font-size: small; border-collapse: collapse;"> <tr> <td><u>DEC.</u></td> <td><u>INCH</u></td> <td><u>mm</u></td> <td><u>ANGLE</u></td> </tr> <tr> <td>.X</td> <td>±0.1</td> <td>[±2.5]</td> <td>±7' 30"</td> </tr> <tr> <td>.XX</td> <td>±0.02</td> <td>[±0.51]</td> <td></td> </tr> <tr> <td>.XXX</td> <td>±0.005</td> <td>[±0.127]</td> <td></td> </tr> <tr> <td>.XXXX</td> <td>±0.0005</td> <td>[±0.0127]</td> <td></td> </tr> </table>	<u>DEC.</u>			<u>INCH</u>	<u>mm</u>	<u>ANGLE</u>	.X	±0.1	[±2.5]	±7' 30"	.XX	±0.02	[±0.51]		.XXX	±0.005	[±0.127]		.XXXX	±0.0005	[±0.0127]		DATE <b>09-27-1996</b>
<u>DEC.</u>	<u>INCH</u>	<u>mm</u>	<u>ANGLE</u>																							
.X	±0.1	[±2.5]	±7' 30"																							
.XX	±0.02	[±0.51]																								
.XXX	±0.005	[±0.127]																								
.XXXX	±0.0005	[±0.0127]																								
ECO DESCRIPTION <b>UPDATED TO SOLIDWORKS</b>			APPROVED BY <b>GK</b>	DATE <b>09-30-1996</b>	MATERIAL	PROCESS/FINISH																				
COPYRIGHT REGAL BELOIT AMERICA, INC. ALL RIGHTS RESERVED. PROPRIETARY AND CONFIDENTIAL INFORMATION - THIS DOCUMENT IS THE PROPERTY OF REGAL BELOIT AMERICA, INC. ("OWNER") AND CONTAINS OWNER'S PROPRIETARY INFORMATION. ANY PERSON, CORPORATION OR OTHER FIRM RECEIVING IT IS DEEMED, BY RECEIVING IT, TO AGREE THAT IT, AND/OR ANY PART OF IT, SHALL NOT BE DISCLOSED TO ANY PERSON, CORPORATION OR OTHER ENTITY, DUPLICATED, AND/OR USED, EXCEPT AS EXPRESSLY APPROVED IN WRITING IN ADVANCE BY OWNER. THIS DOCUMENT SHALL BE RETURNED TO OWNER UPON REQUEST. IT MAY BE SUBJECT TO CERTAIN RESTRICTIONS UNDER APPLICABLE EXPORT CONTROL LAWS AND REGULATIONS.			REMOVE BURRS & BREAK SHARP EDGES: .003/.015 [.076/.381] X 45° CORNER FILLETS: R.02 [.51] MACHINED SURFACES: 200 $\sqrt{\text{INCH}}$ 5.1 $\sqrt{\text{mm}}$ mm SHOWN IN [BRACKETS]	REFERENCE	SIZE <b>A</b>	DRAWING NUMBER <b>EE7300U</b>	SHEET <b>1 OF 1</b>																			
				THIRD ANGLE PROJECTION																						



DATA VOLTS: 460

CERTIFICATION DATA SHEET

CONN. DIAGRAM: EE7300U  
 OUTLINE: SS312940-324TS  
 WINDING: HE32002008 NONE 1

MODEL #: 324TSTFC06501  
 CAT #: E609A  
 MOUNTING: F1/F2 CAPABLE

TYPICAL MOTOR PERFORMANCE DATA

HP	KW	SYNC RPM	FL RPM	FRAME	ENCLOSURE	TYPE	KVA CODE	DESIGN
40	30	3600	3565	324TS	TEFC	TFC	G	B

PH	HZ	VOLTS	AMPS	START TYPE	DUTY	INSL	S.F.	AMB (° C)	ELEV.(Ft)
3	60	460	46	LINE OR INVERTER	CONT	H	1.15	40	3300

F.L. EFF	92.4	3/4 LD EFF	93.0	1/2 LD EFF	91.7	GTD EFF	91.7	ELECT. TYPE
F.L. PF	88.0	3/4 LD PF	85.0	1/2 LD PF	77.5	91.7		SQ CAGE INV RATED

F.L. TORQUE	LR AMPS @ 460 V	L.R. TORQUE	B.D. TORQUE	F.L. RISE (° C)
59.0 LB-FT	290	95.0 LB-FT 161%	162 LB-FT 275%	60

SOUND PRESSURE @	SOUND	ROTOR WK <sup>1</sup>	MAX. LOAD WK <sup>1</sup>	SAFE STALL TIME	STARTS/HOUR	APROX. MOTOR
77 dBA	86 dBA	4.8 LB-FT <sup>2</sup>	25 LB-FT <sup>2</sup>	20 SEC.	2	600 LB.

\*\*\* SUPPLEMENTAL INFORMATION \*\*\*

DE BRACKET TYPE	ODE BRACKET TYPE	MOUNT TYPE	MOTOR ORIENTATION	SEVERE DUTY	HAZARDOUS LOCATION	DRIP COVER	SCREENS	PAINT
STANDARD	STANDARD	RIGID	HORIZONTAL	PREMIUM SEVERE DUTY	DIVISION 2 T2B	NO	NONE	BLUE (EPOXY)

BEARINGS		GREASE	SHAFT TYPE	SPECIAL DE	SPECIAL ODE	SHAFT MATERIAL	FRAME MATERIAL
DE	ODE						
BALL	BALL	POLYREX EM	TS	NONE	NONE	1045 HOT ROLLED (C-204)	CAST IRON
6312	6212						

THERMOSTATS	PROTECTORS	WDG RTD's	BRG RTD's	THERMISTORS	CONTROL	SPACE HEATERS
NONE	NOT	NONE	NONE	NONE	FALSE	NA

R1 (ohms/ph)	R2 (ohms/ph)	X1 (ohms/ph)	X2 (ohms/ph)	Xm (ohms/ph)	VIBRATION (in/sec)
0.11	0.057	0.539	0.596	17.373	0.080

If Inverter equals NONE, contact factory for further information

* N O T E S *		INVERTER TORQUE: CONSTANT 2:1/VARIABLE 10:1
		INV. HP SPEED RANGE: NONE
		ENCODER: NONE
		NONE NONE NONE PPR
		BRAKE: NONE NONE NONE

PREPARED BY: ANUSHA M  
 DATE: 3/10/2020  
 FT-LB: NA  
 VOLTAGE: NONE HZ:

FORM: 3531 REV\_4 2/27/06  
 \*\* Subject to change without notice.

