

PRODUCT INFORMATION PACKET

Model No: 184TTFCD6505

Catalog No: E655A

5 HP, Severe Duty Motors, 3 phase, 3600 RPM, 575 V, 184T Frame, TEFC
Other Severe Duty Motors





Nameplate Specifications

Output HP	5 Hp	Output KW	3.7 kW
Frequency	60 Hz	Voltage	575 V
Current	4.8 A	Speed	3510 rpm
Service Factor	1.15	Phase	3
Efficiency	88.5 %	Power Factor	88
Duty	Continuous	Insulation Class	H
Design Code	B	KVA Code	H
Frame	184T	Enclosure	Totally Enclosed Fan Cooled
Thermal Protection	No	Ambient Temperature	40 °C
Drive End Bearing Size	6206	Opp Drive End Bearing Size	6205
UL	Listed	CSA	Y
CE	Y	IP Code	55
Hazardous Location	DIVISION 2 T2B		

Technical Specifications

Electrical Type	Squirrel Cage Inverter Rated	Starting Method	Line Or Inverter
Poles	2	Rotation	Selective Clockwise
Resistance Main	3.55 Ohms	Mounting	Rigid Base
Motor Orientation	Horizontal	Drive End Bearing	Ball
Opp Drive End Bearing	Ball	Frame Material	Cast Iron
Shaft Type	T	Shaft Diameter	1.125 in
Assembly/Box Mounting	F1/F2 CAPABLE		
Outline Drawing	SS600210-184T	Connection Drawing	EE7300

This is an uncontrolled document once printed or downloaded and is subject to change without notice. Date Created:20/08/2020

OUTLINE

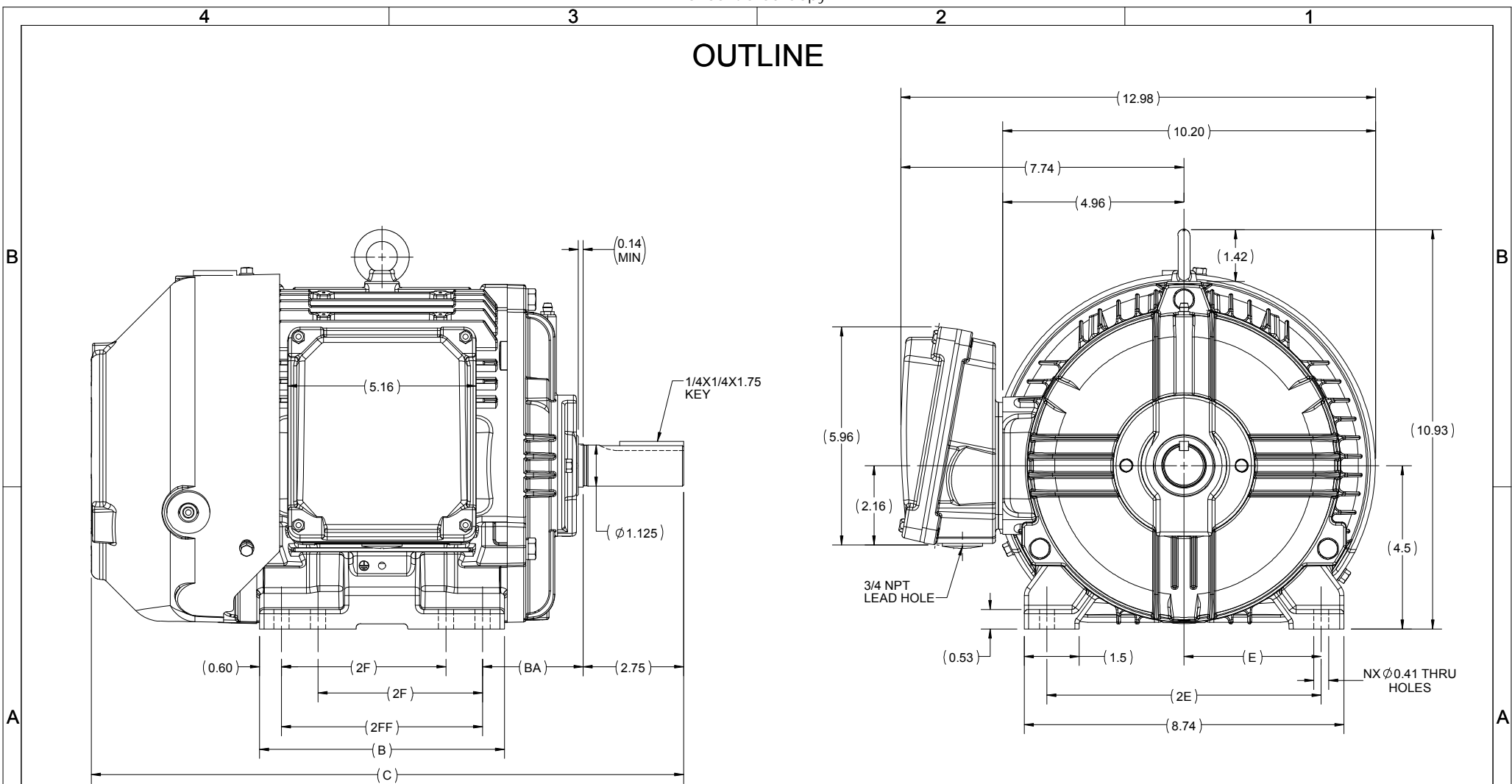

182/184T	6.69	16.20	5.50	4.50				8	F1 OR F2
182T	5.67	15.20	4.50	-	2.75	3.75	7.50	4	F1 OR F2
FRAME	B	C	2FF	2F	BA	E	2E	N	MOUNTING

DRAWING REVISION B	REVISION BY BISWA	DATE 25/01/2019
ECO ECO-0160791	APPROVED BY SBD	DATE 25/01/2019
ECO DESCRIPTION DRAWING UPDATED		
<small>COPYRIGHT REGAL BELOIT AMERICA, INC. ALL RIGHTS RESERVED. PROPRIETARY AND CONFIDENTIAL INFORMATION - THIS DOCUMENT IS THE PROPERTY OF REGAL BELOIT AMERICA, INC. (OWNER) AND CONTAINS OWNERS PROPRIETARY INFORMATION. ANY PERSON, CORPORATION OR OTHER FIRM RECEIVING IT IS DEEMED, BY RECEIVING IT, TO AGREE THAT IT, AND/OR ANY PART OF IT, SHALL NOT BE DISCLOSED TO ANY PERSON, CORPORATION OR OTHER ENTITY, DUPLICATED, AND/OR USED, EXCEPT AS EXPRESSLY APPROVED IN WRITING IN ADVANCE BY OWNER. THIS DOCUMENT SHALL BE RETURNED TO OWNER UPON REQUEST. IT MAY BE SUBJECT TO CERTAIN RESTRICTIONS UNDER APPLICABLE EXPORT CONTROL LAWS AND REGULATIONS.</small>		

DRAWN BY BISWA	 Regal Beloit America, Inc.
DATE 24/12/2018	
APPROVED BY SBD	DESCRIPTION OUTLINE 182/184T FR-NEMA-SD & IEEEE841
DATE 24/12/2018	MATERIAL
REFERENCE	PROCESS/FINISH
THIRD ANGLE PROJECTION	SIZE B
	DRAWING NUMBER SS600210
	SHEET 1 OF 1

**THREE PHASE - SINGLE VOLTAGE
MOTOR - CONDUIT BOX @ 'A'**

**TO REVERSE ROTATION:
INTERCHANGE ANY TWO
LINE LEAD CONNECTIONS.**

TERMINAL BLOCK WHEN SPECIFIED



VIEW OF TERMINAL END

**IF MOTOR HAS
6 LEADS**



A-9806 DECAL

**OPTIONAL CORD
CONNECTION**



DRAWING REVISION AB	REVISION BY JJB	DATE 06-27-2017
ECO ECO-0125361	APPROVED BY TB	DATE 06-27-2017
ECO DESCRIPTION UPDATED TO CURRENT STANDARDS		
<small>COPYRIGHT REGAL BELOIT AMERICA, INC. ALL RIGHTS RESERVED. PROPRIETARY AND CONFIDENTIAL INFORMATION - THIS DOCUMENT IS THE PROPERTY OF REGAL BELOIT AMERICA, INC. ("OWNER") AND CONTAINS OWNER'S PROPRIETARY INFORMATION. ANY PERSON, CORPORATION OR OTHER FIRM RECEIVING IT IS DEEMED, BY RECEIVING IT, TO AGREE THAT IT, AND/OR ANY PART OF IT, SHALL NOT BE DISCLOSED TO ANY PERSON, CORPORATION OR OTHER ENTITY, DUPLICATED, AND/OR USED, EXCEPT AS EXPRESSLY APPROVED IN WRITING IN ADVANCE BY OWNER. THIS DOCUMENT SHALL BE RETURNED TO OWNER UPON REQUEST. IT MAY BE SUBJECT TO CERTAIN RESTRICTIONS UNDER APPLICABLE EXPORT CONTROL LAWS AND REGULATIONS.</small>		



DRAWN BY DA
DATE 03-26-1993
APPROVED BY TB
DATE 03-26-1993
REFERENCE
THIRD ANGLE PROJECTION

Regal Beloit America, Inc.	
DESCRIPTION CONNECTION DIAGRAM EXTERNAL - SINGLE VOLTAGE - 3Ø MOTOR	
MATERIAL	PROCESS/FINISH
SIZE A	DRAWING NUMBER EE7300
SHEET 1 OF 1	



DATA VOLTS: 460

CERTIFICATION DATA SHEET

CONN. DIAGRAM: EE7300 REFERENCE MODEL #: 184TTFCD6505
 OUTLINE: SS600210-184T CAT #: E655A
 WINDING: HE31122016 NONE 2 MOUNTING: F1/F2 CAPABLE

TYPICAL MOTOR PERFORMANCE DATA

HP	KW	SYNC RPM	FL RPM	FRAME	ENCLOSURE	TYPE	KVA CODE	DESIGN					
5	3.7	3600	3510	184T	TEFC	TFC	H	B					
PH	HZ	VOLTS	AMPS	START TYPE	DUTY	INSL	S.F.	AMB (°C)	ELEV.(FT)				
3	60	575	4.8	LINE OR INVERTER	CONT	H	1.15	40	3300				
F.L. EFF		88.5	3/4 LD EFF		88.5	1/2 LD EFF		87.5	GTD EFF		87.5	ELECT. TYPE	
F.L. PF		88.0	3/4 LD PF		83.0	1/2 LD PF		73.0	SQ CAGE INV RATED				
F.L. TORQUE		LR AMPS @ 460 V		L.R. TORQUE		B.D. TORQUE		F.L. RISE (°C)					
7.5	LB-FT	33.6	16.2	LB-FT	216%	23.0	LB-FT	307%	65				
SOUND PRESSURE @	SOUND	ROTOR WK ²	MAX. LOAD WK ²	SAFE STALL TIME	STARTS/HOUR	APROX.							
70	dB	79	dB	0.23	LB-FT ²	5.5	LB-FT ²	15	SEC.	2	111	LB.	
*** SUPPLEMENTAL INFORMATION ***													
DE BRACKET TYPE	ODE BRACKET TYPE	MOUNT TYPE	MOTOR ORIENTATION	SEVERE DUTY	HAZARDOUS LOCATION	DRIP COVER	SCREENS	PAINT					
STANDARD	STANDARD	RIGID	HORIZONTAL	PREMIUM SEVERE DUTY	DIVISION 2 T2B	NO	NONE	BLUE (EPOXY)					
BEARINGS		GREASE	SHAFT TYPE	SPECIAL DE	SPECIAL ODE	SHAFT	MATERIAL	FRAME MATERIAL					
DE	ODE												
BALL	BALL	POLYREX EM	T	NONE	NONE	1045	HOT ROLLED (C-204)	CAST IRON					
6206	6205												
THERMOSTATS	PROTECTORS	WDG RTD's	BRG RTD's	THERMISTORS	CONTROL		SPACE	HEATERS					
NONE	NOT	NONE	NONE	NONE	FALSE			NA					
R1 (ohms/ph)	R2 (ohms/ph)	X1 (ohms/ph)	X2 (ohms/ph)	Xm (ohms/ph)	VIBRATION (in/sec)		FLOAT						
3.278	1.595	6.202	2.481	175.593	0.080		ODE						
* N O T E S *						If Inverter equals NONE, contact factory for further information							
						INVERTER TORQUE: CONSTANT 2:1/VARIABLE 10:1							
						INV. HP SPEED RANGE: NONE							
						ENCODER: NONE							
						NONE PPR							
PREPARED BY: ANUSHA M					BRAKE: NONE								
DATE: 3/18/2020					NONE NA NONE								
					FT-LB: NA								
					VOLTAGE: NONE HZ:								

FORM: 3531 REV_4 2/27/06
 ** Subject to change without notice.

