

# PRODUCT INFORMATION PACKET



Model No: M1120062.00  
Catalog No: M1120062.00  
Sub-Fractional Motor, 0.25 HP, 90 V, 3500 RPM, 31 Frame, TENV



Regal and LEESON are trademarks of Regal Rexnord Corporation or one of its affiliated companies.  
©2025 Regal Rexnord Corporation, All Rights Reserved. MC017097E





**Nameplate Specifications**

Output HP	0.25 Hp	Output KW	0.19 kW
Voltage	90 V	Speed	3500 rpm
Service Factor	1.0	Frame	31
Enclosure	Totally Enclosed Non Ventilating	Thermal Protection	No Protection
Efficiency	84 %	Ambient Temperature	40 °C
Current	2.6 A	Duty	Continuous
Insulation Class	H	Drive End Bearing Size	6201-13
Opp Drive End Bearing Size	6201-13	UL	Recognized
CSA	Y	CE	Y

**Technical Specifications**

Rotation	Reversible	Mounting	Round
Overall Length	9.45 in	Frame Length	5.50 in
Shaft Diameter	0.500 in	Shaft Extension	1.5 in
Torque	72 OZ-IN		
Outline Drawing	M1031034-M1120062	Connection Drawing	M1005321

This is an uncontrolled document once printed or downloaded and is subject to change without notice. Date Created:04/08/2025

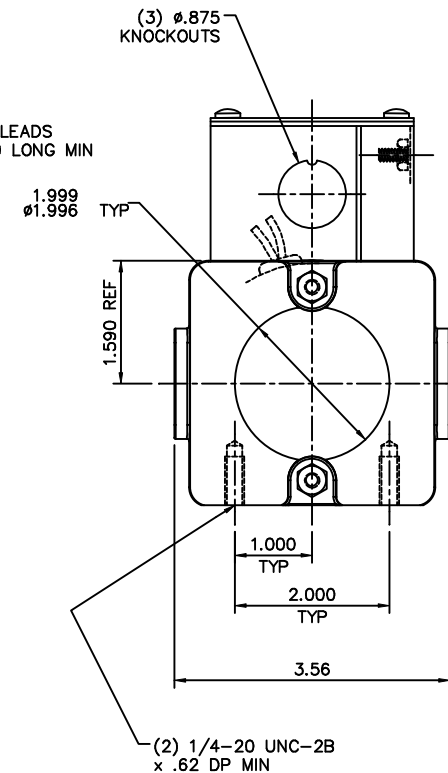
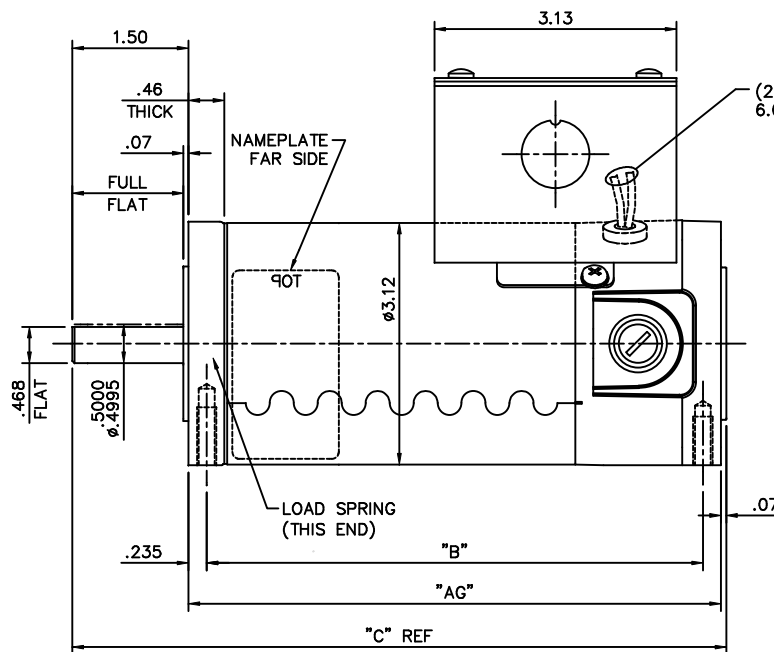
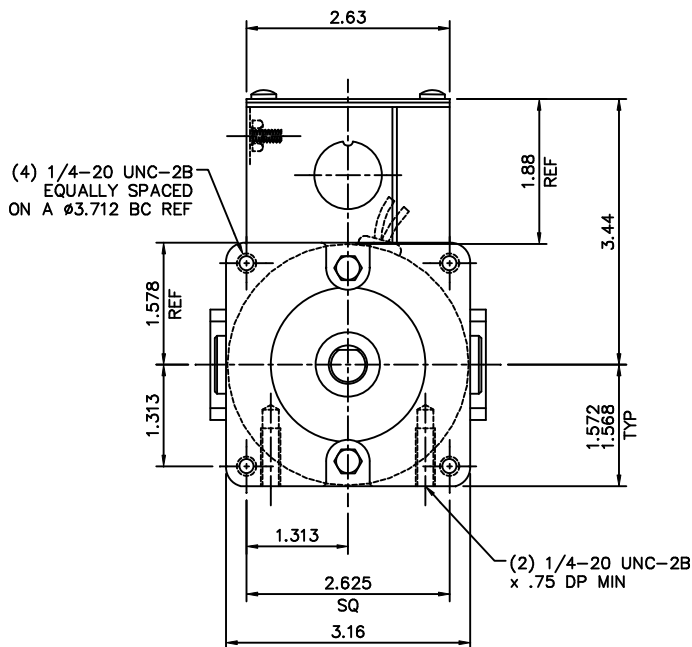

M1120062.00	7.88	7.42	9.45	90	1/4	3500
M1120060.00	5.38	4.92	6.95	90	1/10	3500
M1120059.00	5.88	5.42	7.45	90	1/8	3500
M1120058.00	6.88	6.42	8.45	90	1/6	3500
M1120045.00	6.88	6.42	8.45	180	1/8	1750
M1120043.00	7.88	7.42	9.45	180	1/6	1750
M1120042.00	7.88	7.42	9.45	90	1/6	1750
M1120041.00	6.38	5.92	7.95	180	1/10	1750
M1120040.00	4.88	4.42	6.45	12/24	1/14-1/7	1750/4200
M1120039.00	5.38	4.92	6.95	180	1/15	1750
M1120027.00	6.88	6.42	8.45	90	1/8	1750
M1120014.00	5.88	5.42	7.45	90	1/10	1750
M1120013.00	5.38	4.92	6.95	90	1/15	1750
CATALOG NO.	"AG" DIM	"B" DIM	"C" DIM	VOLT	H.P.	RPM

NOTES:  
 1) END CAP MOUNTING FEET TO BE PARALLEL TO EACH OTHER WITHIN .002

14	ADDED M1120060.00 TO TABLE, ECN 07-1640	IPG	5/18/07	SAD	TOLERANCES UNLESS SPECIFIED	 ELECTRIC MOTORS GEARMOTORS AND DRIVES	DRAWN	IPG 11/9/06			
13	ADDED M1120059.00 TO TABLE, ECN 07-1638	IPG	5/18/07	SAD	DEC.		INCHES	CHK	SAD 11/9/06		
12	CAT. M1120040.00: "AG" WAS 5.38, "B" WAS 4.92, "C" WAS 6.95, ECN 07-1635	IPG	5/18/07	SAD	.X		±.1	APPD			
11	ADDED M1120058.00 TO TABLE, ECN 07-1637	IPG	5/17/07	SAD	.XX		±.03	SCALE	5=8		
10	ADDED M1120027.00 TO TABLE, ECN 07-1633	IPG	5/16/07	SAD	.XXXX	±.0005	REF	M1030240.00			
NO.	REVISION	BY & DATE	CHK	ANG	±1/2"	FINISH	FMF	M1120014.00			
THIS DRAWING IN DESIGN AND DETAIL IS OUR PROPERTY AND MUST NOT BE USED EXCEPT IN CONNECTION WITH OUR WORK ALL RIGHTS OF DESIGN AND INVENTION ARE RESERVED THIS IS AN ELECTRONICALLY GENERATED DOCUMENT - DO NOT SCALE THIS PRINT						RFP	CAD FILE	M1031034	SIZE	DRAWING NO.	REV.
						DIST	B	M1031034.00	14		

D.C. MOTORS

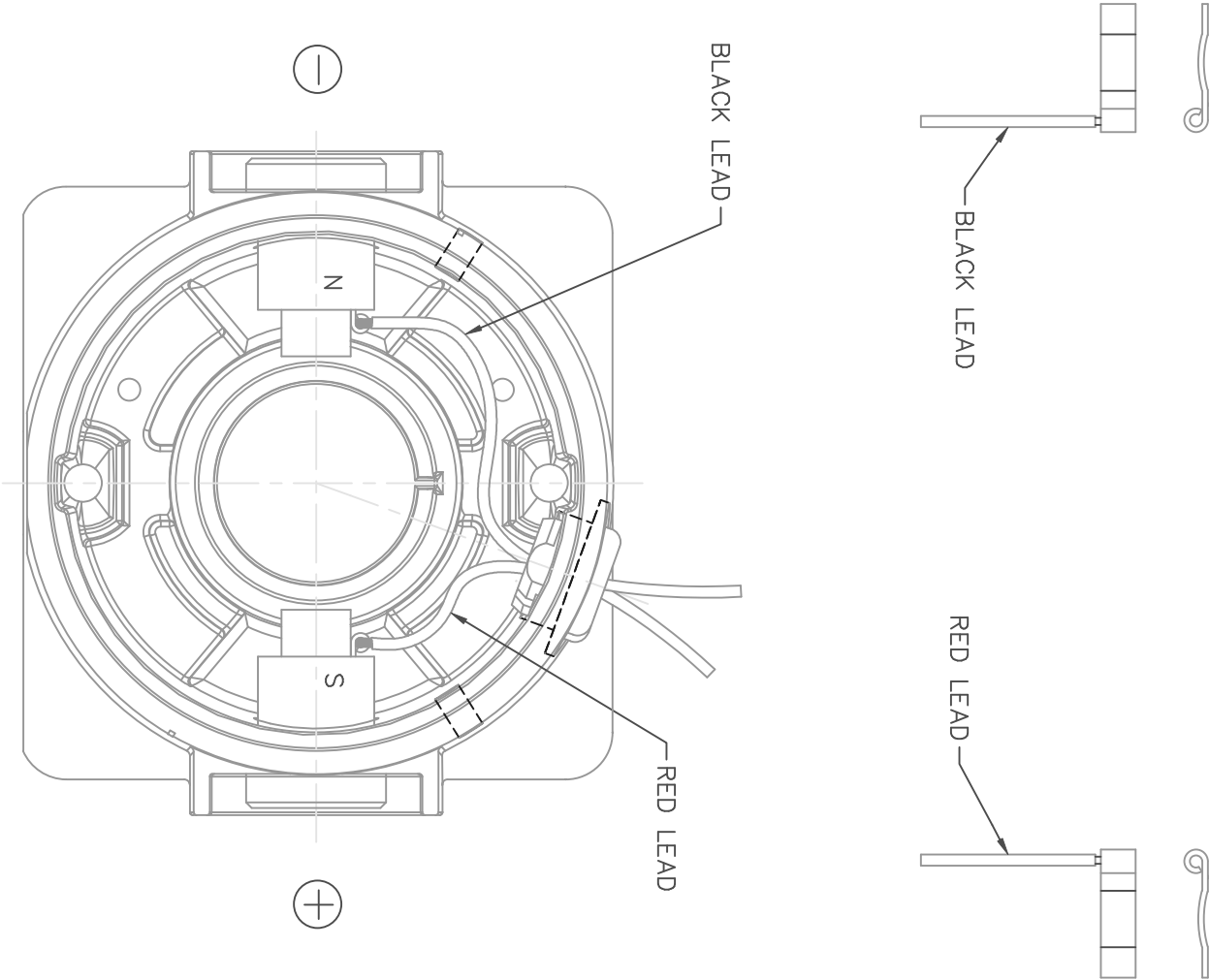

EXTERNAL CONNECTIONS FOR CCW ROTATION  
 VIEWING LEAD END OF MOTOR WITH RED LEAD  
 POSITIVE (+) AND BLACK LEAD NEGATIVE (-).  
 FOR CW ROTATION REVERSE POLARITY.

			TOLERANCES UNLESS SPECIFIED		 ELECTRIC MOTORS GEARMOTORS AND DRIVES	DRAWN	IPG 11/6/06	
			DEC.	INCHES		CHK	SAD 11/6/06	
			.X	±.1		APPD		
			.XX	±.01		TITLE	CONNECTION DIAGRAM	
			.XXX	±.005		SCALE	1=1	
00	RELEASED PER 31 TT FR CONSOLIDATION, ECN 06-4430	IPG 11/6/06	SAD	.XXXX	±.0005	MAT'L.	REF	M1005036.01
NO.	REVISION	BY & DATE	CHK	ANG	±1/2'	FINISH	FMF	M1120014.00
THIS DRAWING IN DESIGN AND DETAIL IS OUR PROPERTY AND MUST NOT BE USED EXCEPT IN CONNECTION WITH OUR WORK ALL RIGHTS OF DESIGN AND INVENTION ARE RESERVED THIS IS AN ELECTRONICALLY GENERATED DOCUMENT - DO NOT SCALE THIS PRINT			RFP	CAD FILE		M1005321	SIZE	DRAWING NO.
			DIST				A	M1005321.01
								REV. 00

# LEESON ELECTRIC CORPORATION

## TYPICAL PERFORMANCE CURVE FOR DIRECT CURRENT PERMANENT MAGNET MOTOR

Model No. <u>CM31D35NZ5</u>	Catalog No. <u>M1120062.00</u>	
HP <u>0.250</u>	RPM <u>3500</u>	DC Volts <u>90.0</u>
F.F. <u>1.38</u>	Encl <u>TENV</u>	Type <u>DN</u>
Max. Amb. <u>40.0 Deg C</u>	Insul. <u>H</u>	Frame <u>31</u>
		N.P. FLA <u>2.60</u>
		S.F. <u>1.00</u>
		Duty <u>CONT</u>

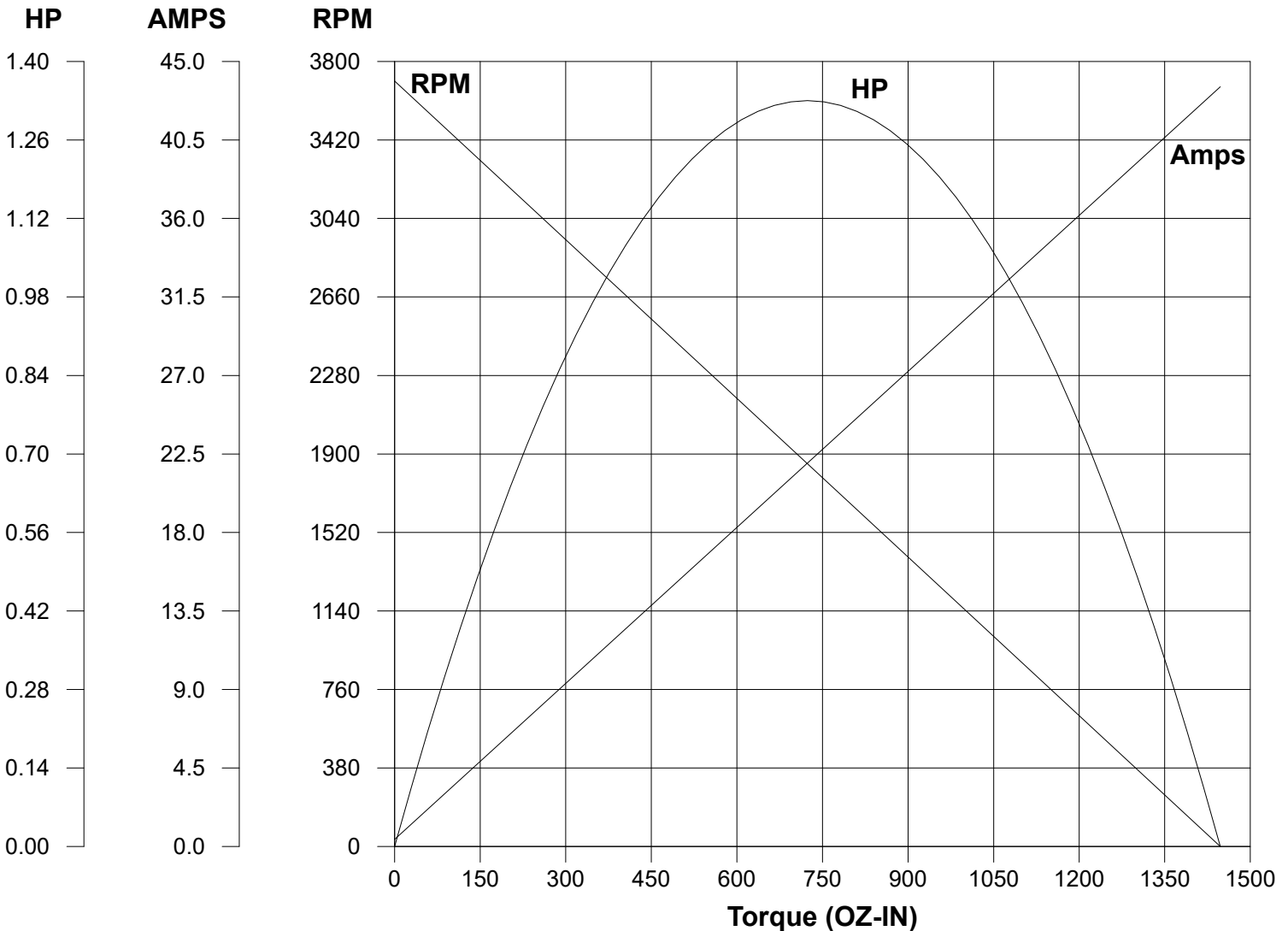

**Ra** 1.3850 Ohms  
**La** 10.60 mHenrys  
**Ja** 10.30 OZ-IN<sup>2</sup>  
**Ke** 23.97 V/KRPM

**Kt** 32.42 OZ-IN/AMP  
**Imax** 43.8 AMPS Allowed  
**FL Torque** 72.00 OZ-IN  
**FL EFF** 84.00 %

**Winding W-** MD312374      **Prepared by** V. Boehlen      **Date** 04-23-2019