

PRODUCT INFORMATION PACKET



Model No: E48PNRA30019

Catalog No: SRi48T3

SyMAX®-SRi Fan & Blower Motor, 0.50 HP, 1 Ph, 60 Hz, 115/230/277 V, 720 RPM, 48Z Frame, TENV



Regal and LEESON are trademarks of Regal Rexnord Corporation or one of its affiliated companies.
©2025 Regal Rexnord Corporation, All Rights Reserved. MC017097E





Nameplate Specifications

Phase	1	Output HP	0.50 Hp
Output KW	0.37 kW	Voltage	115/230/277 V
Speed	1800 rpm	Service Factor	1.00
Frame	48Z	Enclosure	Totally Enclosed Non Ventilated
Thermal Protection	No Protection	Efficiency	80 %
Ambient Temperature	60 °C	Frequency	60 Hz
Current	6.0/3.6/2.9 A	Power Factor	60
Duty	Continuous	Insulation Class	F
Design Code	No Design Code	KVA Code	-
Drive End Bearing Size	6203	Opp Drive End Bearing Size	6203
UL	Recognized	CSA	N
CE	N	IP Code	43
Number of Speeds	1		

Technical Specifications

Electrical Type	AC Permanent Magnet	Starting Method	Across The Line
Poles	10	Rotation	Reversible
Resistance Main	0 Ohms	Mounting	ROUND - EXTENDED STUDS
Motor Orientation	Horizontal	Drive End Bearing	Ball
Opp Drive End Bearing	Ball	Frame Material	Rolled Steel
Shaft Type	Single Special Extension	Assembly/Box Mounting	F1 ONLY
Outline Drawing	E48PNRA30019	Connection Drawing	10050531

This is an uncontrolled document once printed or downloaded and is subject to change without notice. Date Created:07/29/2025

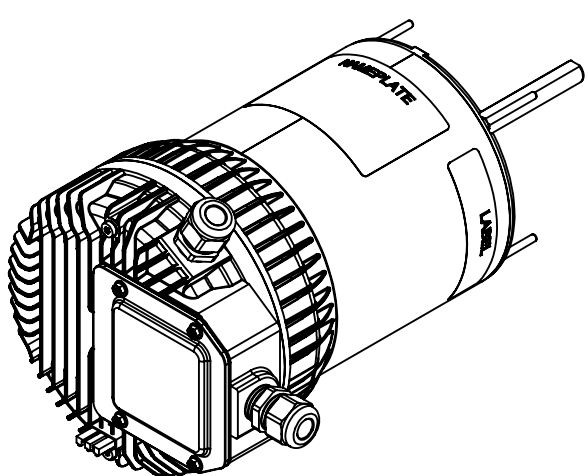
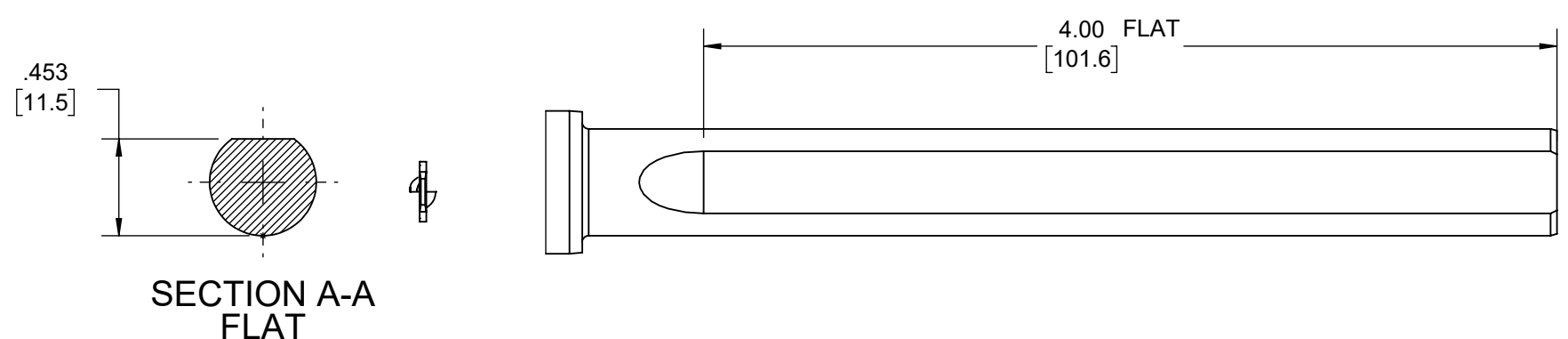
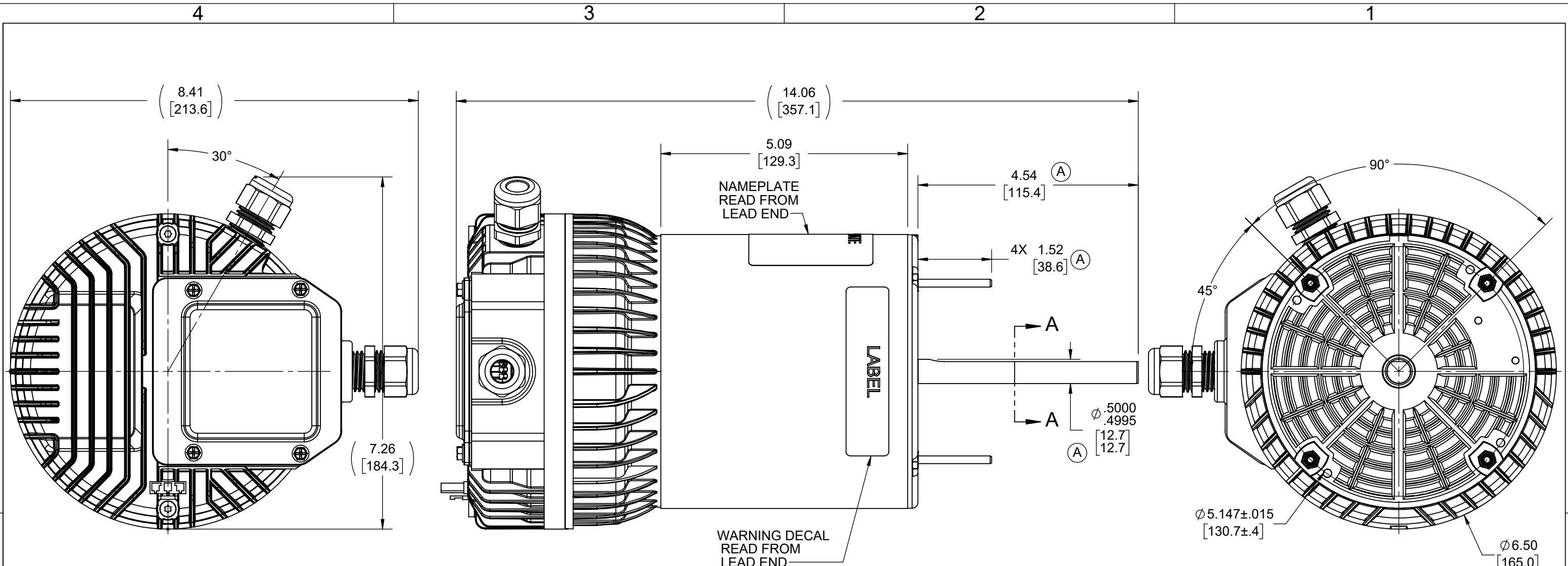

NOTES:
 1. ROHS & REACH REQUIREMENT SEE EP000014_5.1
 2. CTQ REQUIREMENT SEE EP000105-008

CRITICAL TO QUALITY CHARACTERISTICS(CTQs) (P) PROCESS (E) ENGINEERING (A) APPLICATION (R) REGULATORY (L) LIFE	DRAWING REVISION F	REVISION BY LST	REV DATE/© DATE 5/25/23	TOLERANCES (EXCEPT AS NOTED): DEC. INCH mm ANGLE .X ±0.1 [±3] ±0.5° .XX ±0.01 [±0.3] .XXX ±0.005 [±0.13] .XXXX ±0.0005 [±0.013] REMOVE BURRS & BREAK SHARP EDGES: .003/.015 [.08/.38] X 45° CORNER FILLETS: R.02 [.5] MACHINED SURFACES: 125/ 3.2 INCH/mm mm DIMENSIONS IN [BRACKETS] ARE FOR REFERENCE ONLY	DRAWN BY SHESHI		Regal Beloit America, Inc.	
	REQUEST NUMBER ECR-0225971	APPROVED BY LST	DATE 5/25/23		DATE 07/12/2021		DESCRIPTION	
	REQUEST NUMBER DESCRIPTION ADD WARNING DECAL				APPROVED BY SACHIN	OUTLINE		
	<small>COPYRIGHT (PER REVISION DATE) REGAL BELOIT AMERICA, INC. ALL RIGHTS RESERVED. PROPRIETARY AND CONFIDENTIAL INFORMATION - THIS DOCUMENT IS THE PROPERTY OF REGAL BELOIT AMERICA, INC. ("OWNER") AND CONTAINS OWNER'S PROPRIETARY INFORMATION. ANY PERSON, CORPORATION OR OTHER FIRM RECEIVING IT IS DEEMED, BY RECEIVING IT, TO AGREE THAT IT, AND/OR ANY PART OF IT, SHALL NOT BE DISCLOSED TO ANY PERSON, CORPORATION OR OTHER ENTITY, DUPLICATED, AND/OR USED, EXCEPT AS EXPRESSLY APPROVED IN WRITING IN ADVANCE BY OWNER. THIS DOCUMENT SHALL BE RETURNED TO OWNER UPON REQUEST. IT MAY BE SUBJECT TO CERTAIN RESTRICTIONS UNDER APPLICABLE EXPORT CONTROL LAWS AND REGULATIONS.</small>				DATE 07/12/2021	48 FRAME		
					REFERENCE --	MATERIAL	PROCESS/FINISH	
					THIRD ANGLE PROJECTION	SIZE B	DRAWING NUMBER E48PNRA30019	SHEET 1 OF 1

PART NUMBER SUFFIX		1ST DASH CONDITION		2ND DASH CONDITION					REF. HP	(STATOR CORE ASSY)	(SLOT LINER)	⑥ (SPLICE)	(SLEEVE)	⑧ (SPLICE)
1ST DASH NO.	2ND DASH NO.	"DIM A"	"DIM B"	WIRE		TURNS PER COIL	L-L RESISTANCE (OHM)	CONNECTION						
				AWG	MAT'L									
-001		1.181	2.170	18.5	AL	92	3.17	1Y	.50	10023936-002-001	10023937-002-001	10000401-001-001	614062-003	10000401-001-001
-002	-SEE BOM	1.969	2.960	17	AL	57	1.95	1Y	.75	10023936-003-001	10023937-003-001	10000401-001-001	614062-003	10000401-004-001
-003		0.748	1.74	21	AL	156	7.6	1Y	0.166/0.25	10023936-001-001	10023937-001-001	10000401-003-002	614062-003	10000401-001-001

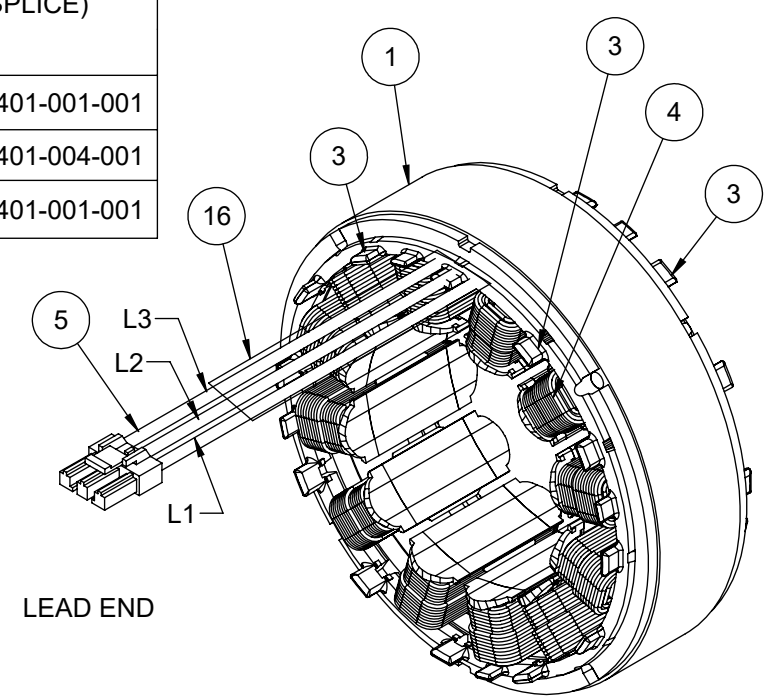
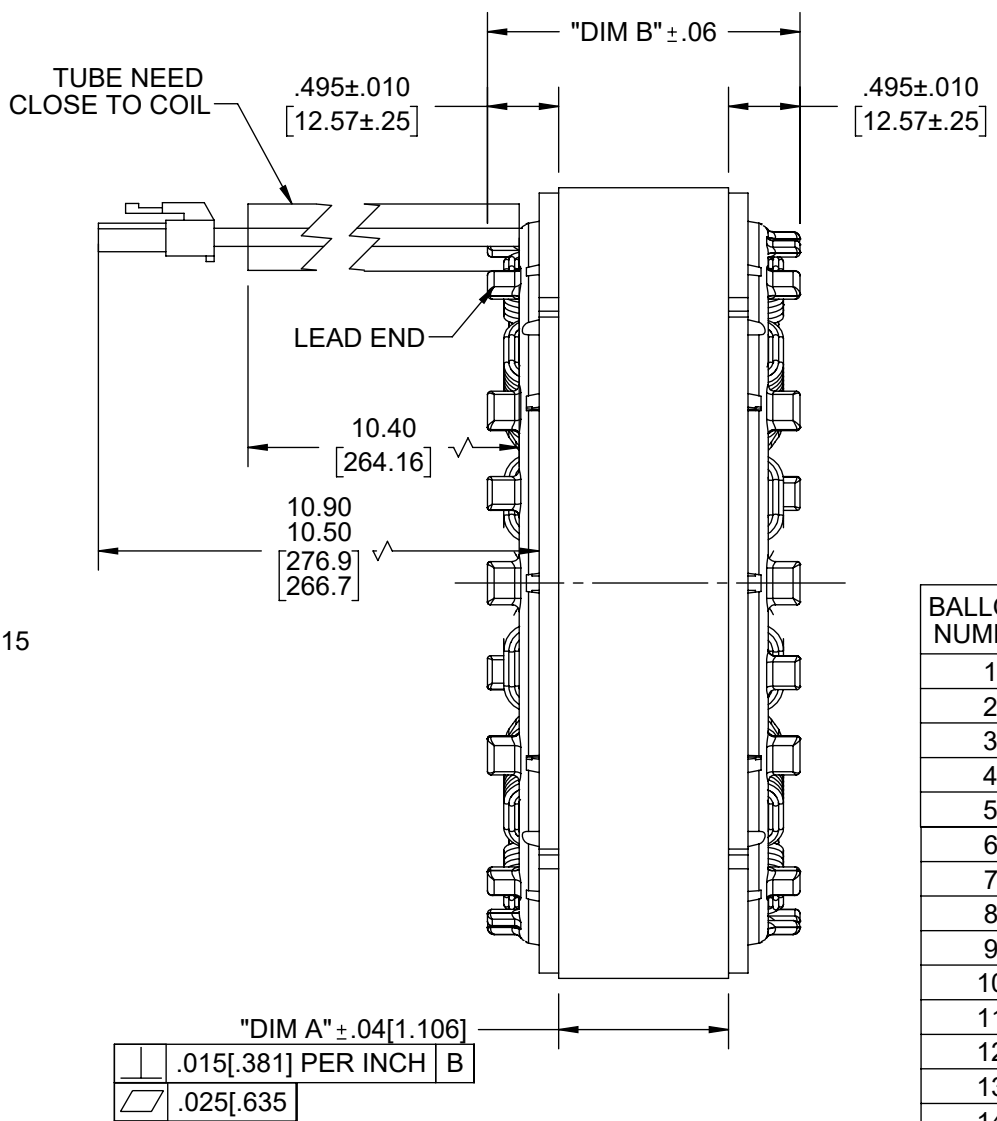
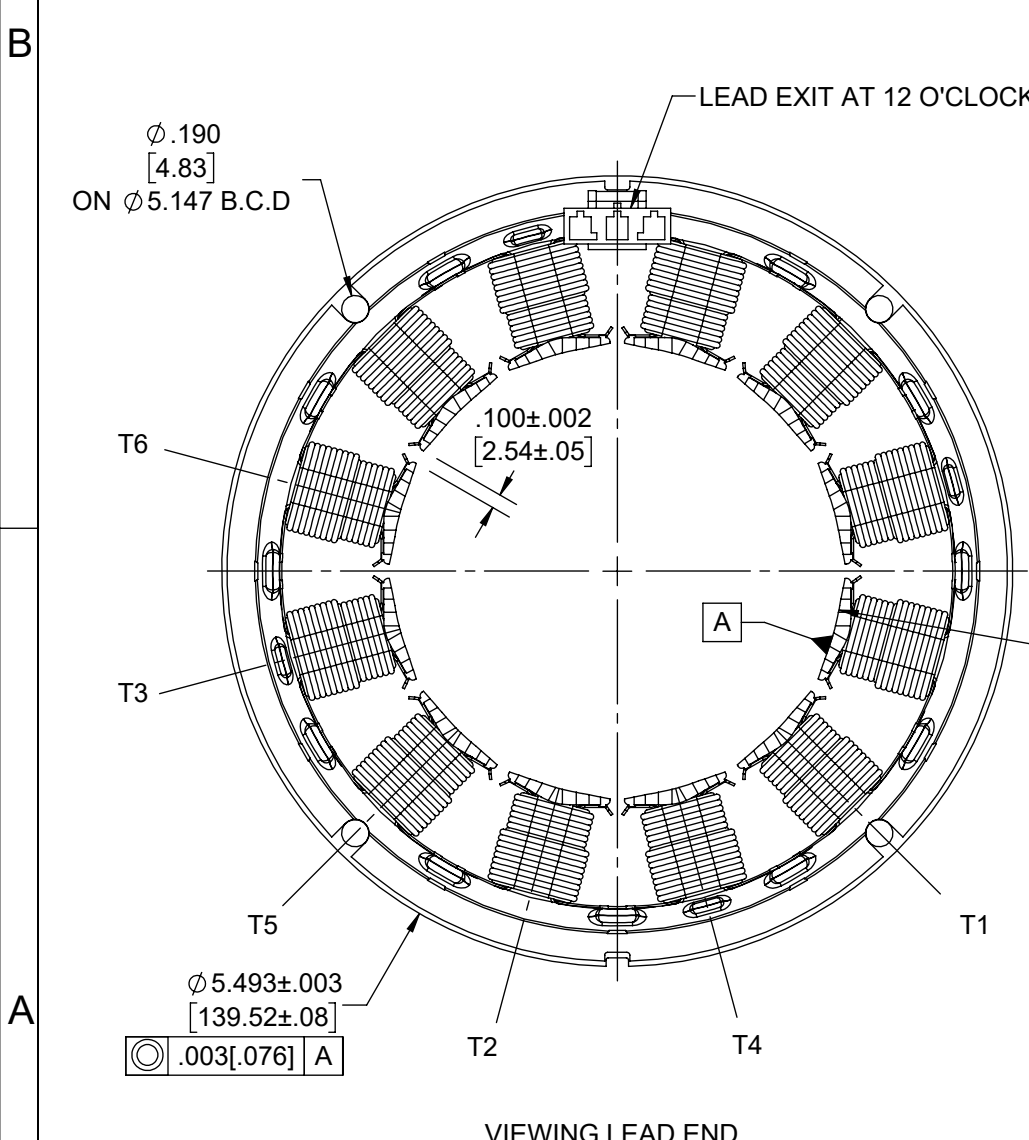

BALLOON NUMBER	PART NUMBER	PART TYPE	QTY.
1	(SEE CHART)	STATOR CORE ASSY	-
2	(SEE CHART)	SLOT LINER	-
3	10020657-001-001	INSULATION-SLOT CAP	-
4	(SEE CHART)	MAGNET WIRE	-
5	10050536-001-001	LEAD ASSY	1
6	(SEE CHART)	SPLICE	4
7	(SEE CHART)	SLEEVE	3
8	(SEE CHART)	SPLICE	3
9	614062-003	SLEEVE	2
10	10006949-003-001	INSULATION SLEEVE	6
11	10006949-004-001	INSULATION SLEEVE	2
12	10006949-007-001	INSULATION SLEEVE	2
13	10006949-008-001	INSULATION SLEEVE	2
14	10015945-001-001	ZIP TIE	10
15	MS5001-015	VARNISH	
16	81.211.4.12	TUBE	0.15M

NOTES:

- CTQ MREQUIREMENT SEE EP000105-008.
- MEET THE REQUIREMENT OF RoHS AND REACH:SEE EP000014_5.1

CRITICAL TO QUALITY CHARACTERISTICS(CTQS) (P) PROCESS (E) ENGINEERING (A) APPLICATION (R) REGULATORY (L) LIFE	DRAWING REVISION D	REVISION BY LST	REV DATE/© DATE 6/7/23	TOLERANCES (EXCEPT AS NOTED): DEC. INCH mm ANGLE .X ±0.1 [±3] ±0.5° .XX ±0.01 [±0.3] .XXX ±0.005 [±0.13] .XXXX ±0.0005 [±0.013] REMOVE BURRS & BREAK SHARP EDGES: .003/.015 [08/.38] X 45° CORNER FILLETS: R.02 [5] MACHINED SURFACES: 125 INCH/mm 3.2 mm DIMENSIONS IN [BRACKETS] ARE FOR REFERENCE ONLY	DRAWN BY SHESHI	Regal Beloit America, Inc. STATOR COIL ASSY 48 FRAME	
	ECO ECR-0226259	APPROVED BY LST	DATE 6/7/23		DATE 06/11/2021		DESCRIPTION
	ECO DESCRIPTION UPDATE DIM A VALUES				APPROVED BY SACHIN		MATERIAL
	<small>COPYRIGHT (PER REVISION DATE) REGAL BELOIT AMERICA, INC. ALL RIGHTS RESERVED. PROPRIETARY AND CONFIDENTIAL INFORMATION - THIS DOCUMENT IS THE PROPERTY OF REGAL BELOIT AMERICA, INC. ("OWNER") AND CONTAINS OWNER'S PROPRIETARY INFORMATION. ANY PERSON, CORPORATION OR OTHER FIRM RECEIVING IT IS DEEMED, BY RECEIVING IT, TO AGREE THAT IT, AND/OR ANY PART OF IT, SHALL NOT BE DISCLOSED TO ANY PERSON, CORPORATION OR OTHER ENTITY, DUPLICATED, AND/OR USED, EXCEPT AS EXPRESSLY APPROVED IN WRITING IN ADVANCE BY OWNER. THIS DOCUMENT SHALL BE RETURNED TO OWNER UPON REQUEST. IT MAY BE SUBJECT TO CERTAIN RESTRICTIONS UNDER APPLICABLE EXPORT CONTROL LAWS AND REGULATIONS.</small>				DATE 06/11/2021		PROCESS/FINISH
				REFERENCE 10023836	SIZE B	DRAWING NUMBER 10050531-XXX	SHEET 1 OF 3

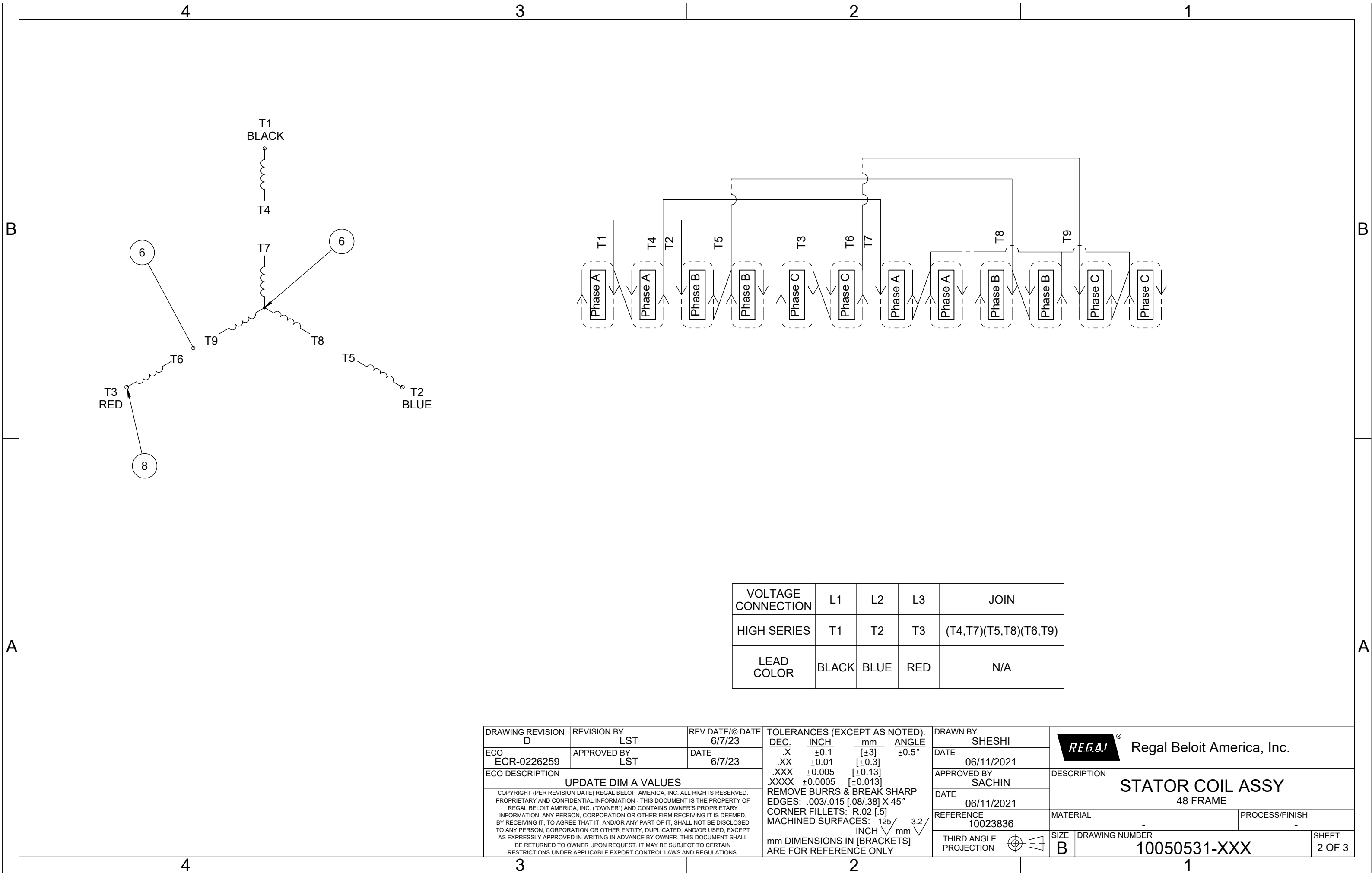



VOLTAGE CONNECTION	L1	L2	L3	JOIN
HIGH SERIES	T1	T2	T3	(T4,T7)(T5,T8)(T6,T9)
LEAD COLOR	BLACK	BLUE	RED	N/A

DRAWING REVISION D	REVISION BY LST	REV DATE/© DATE 6/7/23	TOLERANCES (EXCEPT AS NOTED): DEC. INCH mm ANGLE .X ±0.1 [±3] ±0.5° .XX ±0.01 [±0.3] .XXX ±0.005 [±0.13] .XXXX ±0.0005 [±0.013] REMOVE BURRS & BREAK SHARP EDGES: .003/.015 [.08/.38] X 45° CORNER FILLETS: R.02 [.5] MACHINED SURFACES: 125/ 3.2/ INCH mm mm DIMENSIONS IN [BRACKETS] ARE FOR REFERENCE ONLY	DRAWN BY SHESHI	Regal Beloit America, Inc.	
ECO ECR-0226259	APPROVED BY LST	DATE 6/7/23		DATE 06/11/2021		
ECO DESCRIPTION UPDATE DIM A VALUES COPYRIGHT (PER REVISION DATE) REGAL BELOIT AMERICA, INC. ALL RIGHTS RESERVED. PROPRIETARY AND CONFIDENTIAL INFORMATION - THIS DOCUMENT IS THE PROPERTY OF REGAL BELOIT AMERICA, INC. ("OWNER") AND CONTAINS OWNER'S PROPRIETARY INFORMATION. ANY PERSON, CORPORATION OR OTHER FIRM RECEIVING IT IS DEEMED, BY RECEIVING IT, TO AGREE THAT IT, AND/OR ANY PART OF IT, SHALL NOT BE DISCLOSED TO ANY PERSON, CORPORATION OR OTHER ENTITY, DUPLICATED, AND/OR USED, EXCEPT AS EXPRESSLY APPROVED IN WRITING IN ADVANCE BY OWNER. THIS DOCUMENT SHALL BE RETURNED TO OWNER UPON REQUEST. IT MAY BE SUBJECT TO CERTAIN RESTRICTIONS UNDER APPLICABLE EXPORT CONTROL LAWS AND REGULATIONS.				APPROVED BY SACHIN	DESCRIPTION STATOR COIL ASSY 48 FRAME	
				DATE 06/11/2021		
				REFERENCE 10023836	MATERIAL -	PROCESS/FINISH -
				THIRD ANGLE PROJECTION 	SIZE B	DRAWING NUMBER 10050531-XXX
						SHEET 2 OF 3

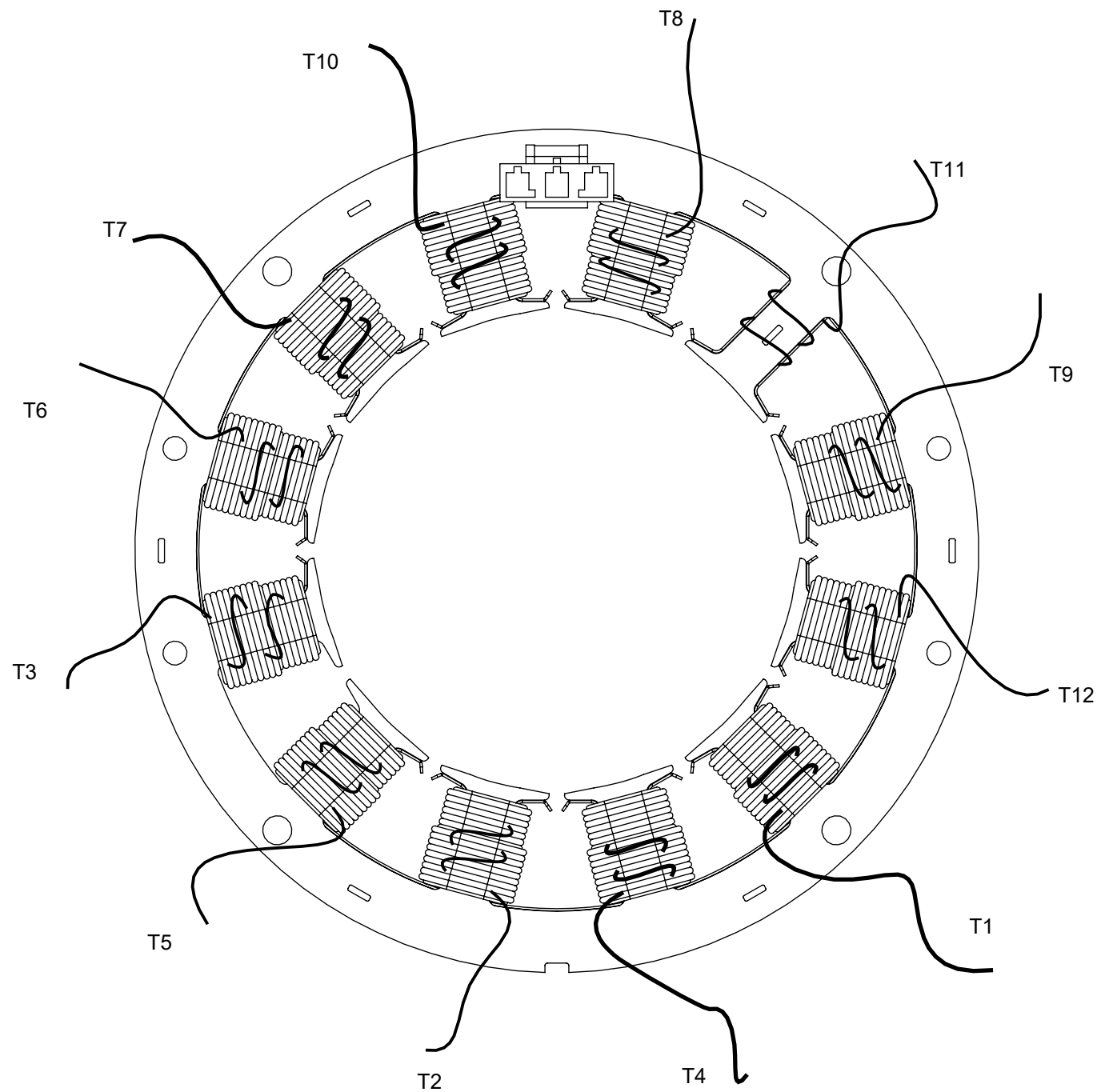
RBC PROPRIETARY AND CONFIDENTIAL INFORMATION
 This document is the property of REGAL BELOIT CORPORATION ("RBC") including its subsidiaries and divisions and contains proprietary information of RBC. This document is loaned on the express condition that neither it nor the information contained therein shall be disclosed to others without the express written consent of RBC, and that the information shall be used by the recipient only as approved expressly by RBC. This document shall be returned to RBC upon its request. This document may be subject to certain restrictions under U.S. export control laws and regulations.



VIEWING LEAD END
 (FOR REFERENCE)

DRAWING REVISION D	REVISION BY LST	REV DATE/© DATE 6/7/23	TOLERANCES (EXCEPT AS NOTED): DEC. INCH mm ANGLE .X ±0.1 [±3] ±0.5° .XX ±0.01 [±0.3] .XXX ±0.005 [±0.13] .XXXX ±0.0005 [±0.013] REMOVE BURRS & BREAK SHARP EDGES: .003/.015 [.08/.38] X 45° CORNER FILLETS: R.02 [.5] MACHINED SURFACES: 125/3.2 INCH/mm mm DIMENSIONS IN [BRACKETS] ARE FOR REFERENCE ONLY	DRAWN BY SHESHI	 Regal Beloit America, Inc.		
ECO ECR-0226259	APPROVED BY LST	DATE 6/7/23		DATE 06/11/2021			
ECO DESCRIPTION UPDATE DIM A VALUES COPYRIGHT (PER REVISION DATE) REGAL BELOIT AMERICA, INC. ALL RIGHTS RESERVED. PROPRIETARY AND CONFIDENTIAL INFORMATION - THIS DOCUMENT IS THE PROPERTY OF REGAL BELOIT AMERICA, INC. ("OWNER") AND CONTAINS OWNER'S PROPRIETARY INFORMATION. ANY PERSON, CORPORATION OR OTHER FIRM RECEIVING IT IS DEEMED, BY RECEIVING IT, TO AGREE THAT IT, AND/OR ANY PART OF IT, SHALL NOT BE DISCLOSED TO ANY PERSON, CORPORATION OR OTHER ENTITY, DUPLICATED, AND/OR USED, EXCEPT AS EXPRESSLY APPROVED IN WRITING IN ADVANCE BY OWNER. THIS DOCUMENT SHALL BE RETURNED TO OWNER UPON REQUEST. IT MAY BE SUBJECT TO CERTAIN RESTRICTIONS UNDER APPLICABLE EXPORT CONTROL LAWS AND REGULATIONS.				APPROVED BY SACHIN	DESCRIPTION STATOR COIL ASSY 48 FRAME		
				DATE 06/11/2021			
				REFERENCE 10023836	MATERIAL -	PROCESS/FINISH -	
				THIRD ANGLE PROJECTION 	SIZE B	DRAWING NUMBER 10050531-XXX	SHEET 3 OF 3