

PRODUCT INFORMATION PACKET



Model No: 145TTGN16034

Catalog No: C322B

Explosion Proof Motor, 2 & 1.50 HP, 3 Ph, 60 & 50 Hz, 230/460 & 190/380 V, 1800 & 1500 RPM,
145TC Frame, EPFC



Regal and LEESON are trademarks of Regal Rexnord Corporation or one of its affiliated companies.
©2025 Regal Rexnord Corporation, All Rights Reserved. MC017097E





Nameplate Specifications

Phase	3	Output HP	2 & 1.50 Hp
Output KW	1.5 & 1.1 kW	Voltage	230/460 & 190/380 V
Speed	1755 & 1465 rpm	Service Factor	1.15 & 1.15
Frame	145TC	Enclosure	Explosion Proof Fan cooled
Thermal Protection	Thermostat	Efficiency	86.5 & 85.5 %
Ambient Temperature	40 °C	Frequency	60 & 50 Hz
Current	6/3 & 5.6/2.8 A	Power Factor	72
Duty	Continuous	Insulation Class	F
Design Code	A	KVA Code	N
Drive End Bearing Size	6205	Opp Drive End Bearing Size	6203
UL	UL Listed And CSA Certified	CSA	Y
CE	N	IP Code	54
Number of Speeds	1	Hazardous Location	DIV 1 EXP PROOF CL I GR D CL II GR FG T3B

Technical Specifications

Electrical Type	Squirrel Cage Induction Run	Starting Method	Across The Line
Poles	4	Rotation	Reversible
Resistance Main	6.51 Ohms	Mounting	Round
Motor Orientation	Horizontal	Drive End Bearing	Ball
Opp Drive End Bearing	Ball	Frame Material	Cast Iron
Shaft Type	T	Overall Length	15.18 in
Frame Length	7.50 in	Shaft Diameter	0.875 in
Shaft Extension	2.12 in	Assembly/Box Mounting	F1 ONLY
Connection Drawing	EE7308T	Outline Drawing	A-108514-750

108514

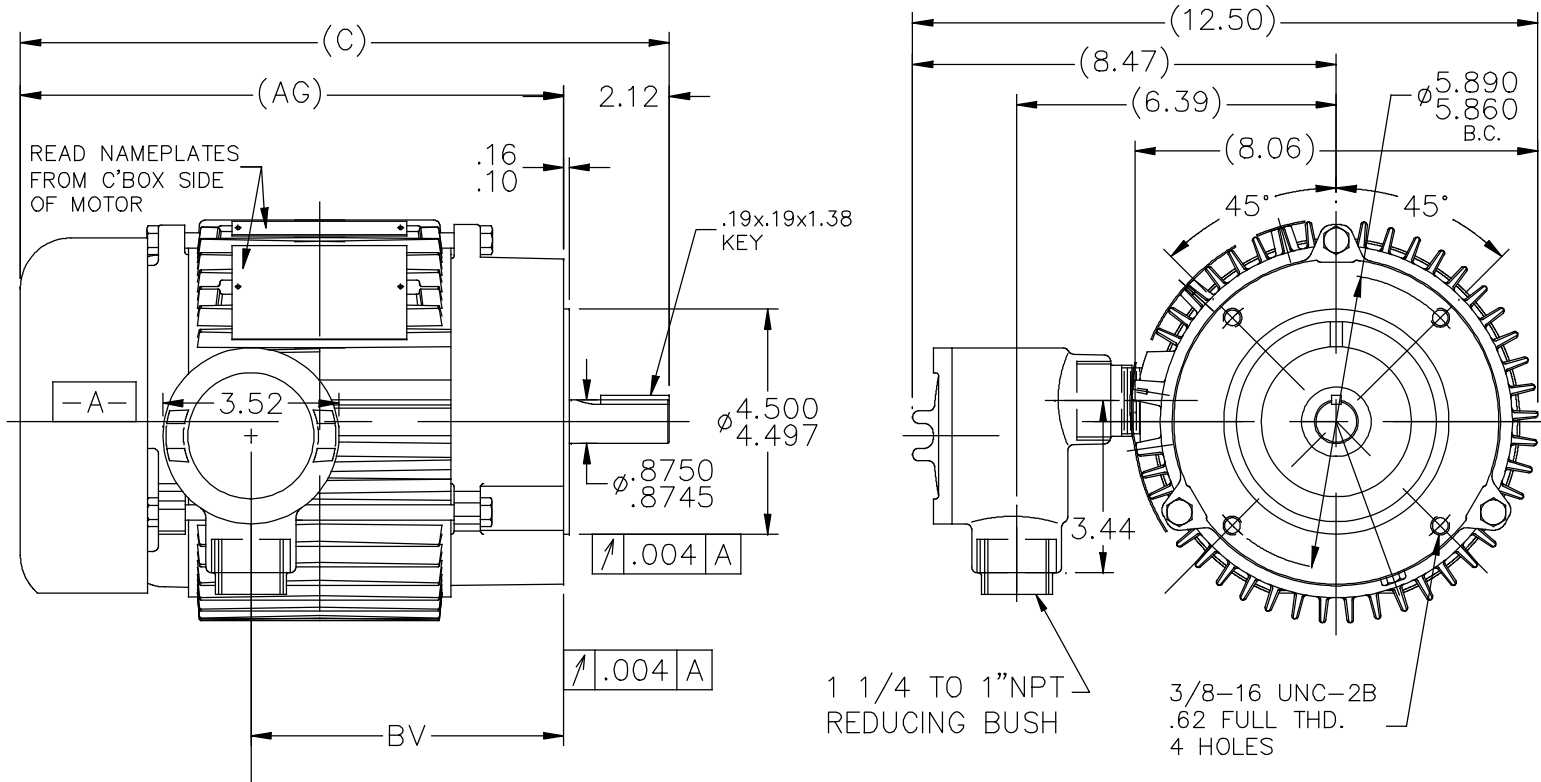

NOTE:

1. BOX CAN ONLY BE ROTATED CLOCKWISE UP TO 270° FROM ITS ORIGINAL POSITION.

DASH	FR.	C	AG	BV
525	143	12.98	10.86	6.25
625	145	13.98	11.86	7.25
750	145	15.18	13.06	8.50

		TOLERANCES UNLESS SPECIFIED		REGAL		DRAWN AS 01/18/17	
		DEC.	INCHES	Regal Beloit America, Inc.		CHK	SM 01/18/17
		.X	±.1	TITLE OUTLINE 140 FR. BB-EXP. PR. -TS-'C'FACE (629 NEW DESIGN)		APPD	SM 01/18/17
		.XX	±.03			SCALE	5=16
B	SHOWN REDUCER IN LEFT SIDE VIEW	SM	06/27/19	.XXX	±.005	REF	100617
A	NEW DRAWING	SM	01/18/17	.XXXX	±.0005	FMF	
NO.	REVISION	BY & DATE	CHK	ANG	±7'30"	PREV	
THIS DRAWING IN DESIGN AND DETAIL IS OUR PROPERTY AND MUST NOT BE USED EXCEPT IN CONNECTION WITH OUR WORK ALL RIGHTS OF DESIGN AND INVENTION ARE RESERVED THIS IS AN ELECTRONICALLY GENERATED DOCUMENT - DO NOT SCALE THIS PRINT				RFP	CAD FILE 108514	SIZE	DRAWING NO. PAGE OF REV.
				DIST	WP	A	108514 B

HIGH VOLTAGE



**THREE PHASE
DUAL VOLTAGE MOTOR**

THERMO-PROTECTORS
CONNECTED IN SERIES



NOTE FOR FACTORY USE ONLY:
TO SURGE TEST FOR COMMON CONNECT:
HIGH VOLT: CONNECT P1 TO T1
THEN P2 TO L1
LOW VOLT: CONNECT P1 TO T1 & T7,
THEN P2 TO L1

LOW VOLTAGE

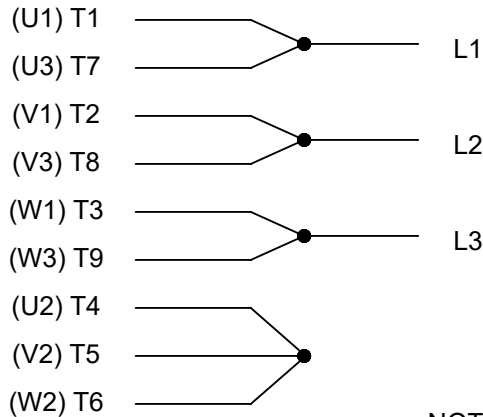

VIEW OF TERMINAL END

NOTE: LEAD'S COLOR CAN BE YELLOW OR WHITE FOR MT2 PLANT

DRAWING REVISION T	REVISION BY ZR	DATE 01-14-2019		DRAWN BY SMC	Regal Beloit America, Inc.	
ECO ECO-0159915	APPROVED BY DR	DATE 01-15-2019		DATE 05-13-1992		
ECO DESCRIPTION ADDED TERMINAL CONNECTION DIAGRAM				APPROVED BY TB	DESCRIPTION CONN DIAGRAM-INTERNAL 3 PHASE - DUAL VOLTAGE MOTOR	
<small>COPYRIGHT REGAL BELOIT AMERICA, INC. ALL RIGHTS RESERVED. PROPRIETARY AND CONFIDENTIAL INFORMATION - THIS DOCUMENT IS THE PROPERTY OF REGAL BELOIT AMERICA, INC. ("OWNER") AND CONTAINS OWNER'S PROPRIETARY INFORMATION. ANY PERSON, CORPORATION OR OTHER FIRM RECEIVING IT IS DEEMED, BY RECEIVING IT, TO AGREE THAT IT, AND/OR ANY PART OF IT, SHALL NOT BE DISCLOSED TO ANY PERSON, CORPORATION OR OTHER ENTITY, DUPLICATED, AND/OR USED, EXCEPT AS EXPRESSLY APPROVED IN WRITING IN ADVANCE BY OWNER. THIS DOCUMENT SHALL BE RETURNED TO OWNER UPON REQUEST. IT MAY BE SUBJECT TO CERTAIN RESTRICTIONS UNDER APPLICABLE EXPORT CONTROL LAWS AND REGULATIONS.</small>				DATE 05-13-1992	MATERIAL	PROCESS/FINISH
			REFERENCE EE7308/EE7300	SIZE A	DRAWING NUMBER EE7308T	SHEET 1 OF 1
			THIRD ANGLE PROJECTION			

CERTIFICATION DATA SHEET

Model#: 145TTGN16034 AA
CONN. DIAGRAM: EE7308T
OUTLINE: A-100617-750

WINDING#: ZT4166 R1 3
ASSEMBLY: F1 ONLY

TYPICAL MOTOR PERFORMANCE DATA

HP	KW	SYNC. RPM	F.L. RPM	FRAME	ENCLOSURE	KVA CODE	DESIGN
2&1 1/2	1.49&1.12	1800	1755&1465	145TC	EPFC	N	A

PH	Hz	VOLTS	FL AMPS	START TYPE	DUTY	INSL	S.F	AMB°C	ELEVATION
3	60/50	230/460#190/ 380	6/3&5.6/2.8	ACROSS THE LINE	CONTINUOU S	F3	1.15/1.15	40	3300

FULL LOAD EFF: 86.5&85.5	3/4 LOAD EFF: 85.5	1/2 LOAD EFF: 82.5	GTD. EFF	ELEC. TYPE	NO LOAD AMPS
FULL LOAD PF: 72&70	3/4 LOAD PF: 63	1/2 LOAD PF: 50	84	SQ CAGE IND RUN	3.8 / 1.9

F.L. TORQUE	LOCKED ROTOR AMPS	L.R. TORQUE	B.D. TORQUE	F.L. RISE°C
6 LB-FT	60 / 30	24.5 LB-FT 408	32.5 LB-FT 542	35

SOUND PRESSURE @ 3 FT.	SOUND POWER	ROTOR WK^2	MAX. WK^2	SAFE STALL TIME	STARTS /HOUR	APPROX. MOTOR WGT
62 dBA	72 dBA	0.13 LB-FT^2	0 LB-FT^2	20 SEC.	2	69 LBS.

***** SUPPLEMENTAL INFORMATION *****

DE BRACKET TYPE	ODE BRACKET TYPE	MOUNT TYPE	ORIENTATION	SEVERE DUTY	HAZARDOUS LOCATION	DRIP COVER	SCREENS	PAINT
C-FACE	STANDARD	ROUND	HORIZONTAL	FALSE	EXP PROOF CL I GR D CL II GR F&G T3B	FALSE	NONE	BLUE (POWDER)

BEARINGS		GREASE	SHAFT TYPE	SPECIAL DE	SPECIAL ODE	SHAFT MATERIAL	FRAME MATERIAL
DE	OPE						
BALL	BALL	POLYREX EM	T	NONE	NONE	1144 STRESSPROOF (C-223)	CAST IRON
6205	6203						

THERMO-PROTECTORS				THERMISTORS	CONTROL	SPACE /n HEATERS
THERMOSTATS	PROTECTORS	WDG RTDs	BRG RTDs			
TSTATS (N/C)	NOT	NONE	NONE	NONE	FALSE	NONE VOLTS

If Inverter equals NONE, contact factory for further information

INVERTER TORQUE: NONE
INV. HP SPEED RANGE: NONE
ENCODER: NONE
NONE NONE
NONE NONE PPR
BRAKE: NONE NONE
NONE P/N NONE
NONE NONE
NONE FT-LB NONE V NONE Hz

*
N
O
T
E
S
*

DATE: 06/27/2017 12:05:22 AM

FORM 3531 REV.3 02/07/99

** Subject to change without notice.

Data Sheet

Date: 19-06-2017
 Customer: _____
 Attention: _____
 Submitted by: FAREEDA DUDEKULA



145TTGN16034

Submittal

Data @ 460 V

Motor Load Data

Load	0%	25%	50%	75%	100%	115%	125%	LR
Current (Amps)	1.90	2.00	2.30	2.60	3.0	3.3	3.5	30.0
Torque (ft-lb)	0.00	1.50	2.95	4.5	6.0	6.9	7.5	24.5
RPM	1800	1790	1780	1770	1755	1,750	1745	0
Efficiency (%)		74.0	82.5	85.5	86.5	86.5	86.5	
P.F. (%)	8.0	31.5	50.0	63.0	72.0	75.5	77.5	69.0

Motor Speed Data

	LR	Pull-Up	BD	Rated	Idle
Speed (RPM)	0	900	1245	1755	1800
Current (Amps)	30.0	25.0	18.7	3.0	1.90
Torque (ft-lb)	24.5	22.1	32.5	6.0	0.00

Information Block				
HP	2.0			
Sync. RPM	1800			
Frame	145			
Enclosure	TEFC			
Construction	TFN			
Voltage	230/460#190/38(V)			
Frequency	60 Hz			
Design	A			
LR Code letter	N			
Service Factor	1.15			
Temp Rise @ FL	35 ° C			
Duty	CONT			
Ambient	40 ° C			
Elevation	1,000 feet			
Rotor/Shaft wk ²	0.13 Lb-Ft ²			
Ref Wdg	ZT4166 R1			
Sound Pressure @ 1M	62 dBA			
VFD Rating	NONE			
Outline Dwg	A-100617-750			
Conn. Diag	EE7308T			
Additional Specifications:				
0				
365THFS8036				
EQUIV CKT (OHMS / PHASE)				
R1	R2	X1	X2	Xm
3.8060	3.0530	5.9070	6.1490	165.4160

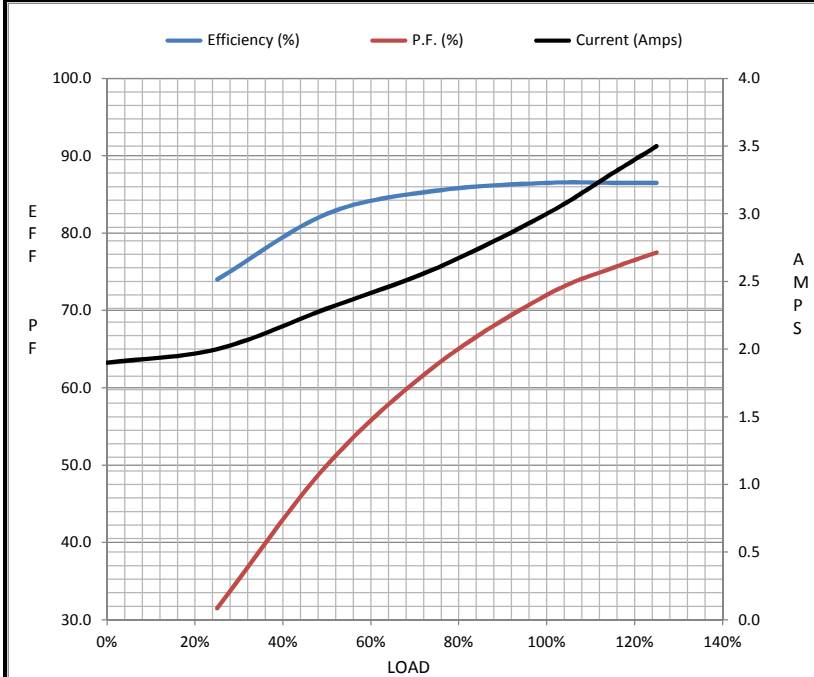

Speed - Torque Curve

