

PRODUCT INFORMATION PACKET



Model No: C6D17EK6A

Catalog No: 118054.00

118054.00..1/3HP..1750RPM.56C.TENV.12VDC.DC.DC.CONT.40C.1.0SF.RIGID C FACE.C6D17EK6.....DC
LOW VOLTAGE EX-PROOF.NONE.....

Explosion Proof



Regal and Leeson are trademarks of Regal Beloit Corporation or one of its affiliated companies.

©2018 Regal Beloit Corporation, All Rights Reserved. MC017097E



Product Information Packet: Model No: C6D17EK6A, Catalog No:118054.00
 118054.00..1/3HP..1750RPM.56C.TENV.12VDC.DC.DC.CONT.40C.1.0SF.RIGID C FACE.C6D17EK6.....DC LOW
 VOLTAGE EX-PROOF.NONE.....



Nameplate Specifications

Output HP	0.33 Hp	Output KW	0.25 kW
Voltage	12 V	Current	28.0 A
Speed	1750 rpm	Service Factor	1
Duty	Continuous	Insulation Class	H
Frame	S56C	Enclosure	Totally Enclosed Non Ventilated
Overload Protector	No	Ambient Temperature	40 °C
UL	Recognized	CSA	Y
CE	N		

Technical Specifications

Rotation	Reversible	Mounting	Rigid C base
Overall Length	12.37 in	Shaft Diameter	0.625 in
Shaft Extension	2.06 in		
Outline Drawing	612-0195-000		

This is an uncontrolled document once printed or downloaded and is subject to change without notice. Date Created: 10/15/2018

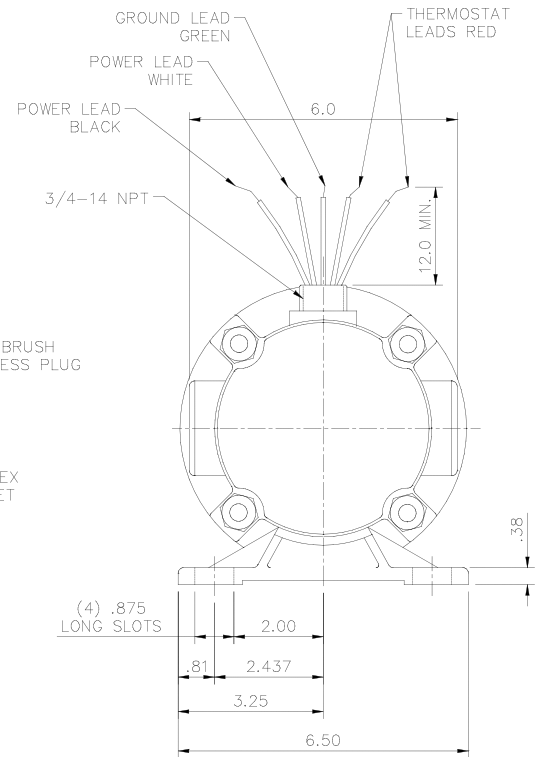
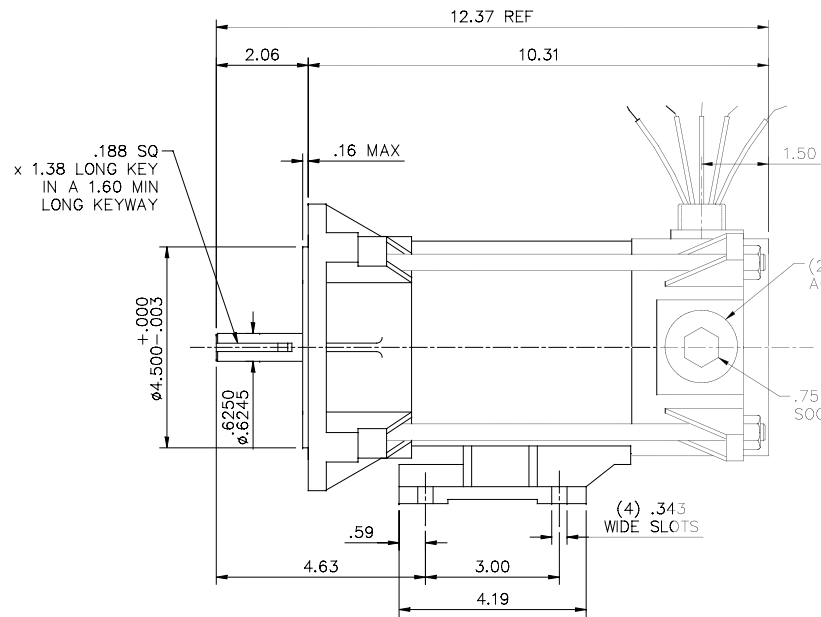
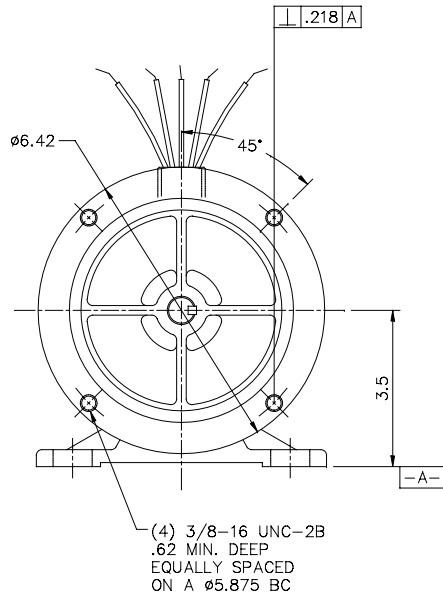

VOLTAGE	12 VDC
HORSEPOWER	1/3
RPM	1750
AMPERES	28
CONTINUOUS DUTY	
PERMANENT MAGNET FIELD	
CLASS H INSULATION	
BALL BEARINGS	

- NOTES:
 1) ALL DIMENSIONS REFERENCE UNLESS TOLERANCED.
 2) UL LISTED (E56538) AND CSA CERTIFIED (LR43478).

ITEM No.	ITEM REV
-000	0

		TOLERANCES UNLESS SPECIFIED		LEESON		ELECTRIC MOTORS GEARMOTORS AND DRIVES		DRAWN IPG 10/22/15		
		DEC.	INCHES					CHK		
		.X	±.1					APPD		
		.XX	±.03	TITLE		OUTLINE		SCALE 3=8		
		.XXX	±.005	EXPLOSION PROOF DC MOTOR		REF 034446		FMF 118054.00		
A	RELEASED, ECO-0086281	IPG	10/22/15	.XXXX	±.0005	MAT'L		PREV		
NO.	REVISION	BY & DATE	CHK	ANG	±1/2'	FINISH				
THIS DRAWING IN DESIGN AND DETAIL IS OUR PROPERTY AND MUST NOT BE USED EXCEPT IN CONNECTION WITH OUR WORK ALL RIGHTS OF DESIGN AND INVENTION ARE RESERVED THIS IS AN ELECTRONICALLY GENERATED DOCUMENT - DO NOT SCALE THIS PRINT				RFP		CAD FILE	612-0195	SIZE	DRAWING NO.	REV.
				DIST				B	612-0195	A