

PRODUCT INFORMATION PACKET



Model No: C6S46DR2E

Catalog No: 113643.00

..1/2-1/4HP..1725/1140RPM.56H.DP.230V.1PH.60HZ.CONT.40C.1.0SF.RESIL.C6S46DR2E.....FAN & BLOWER.NOT.....

2 Speed



Regal and Leeson are trademarks of Regal Beloit Corporation or one of its affiliated companies.

©2018 Regal Beloit Corporation, All Rights Reserved. MC017097E





Nameplate Specifications

Output HP	0.50 Hp	Output KW	0.37 kW
Frequency	60 Hz	Voltage	230 V
Current	3.9 A	Speed	1725 rpm
Service Factor	1	Phase	1
Efficiency	61.7 %	Duty	Continuous
Insulation Class	B	Design Code	NO DESIGN CODE
KVA Code	N	Frame	56H
Enclosure	Drip Proof	Overload Protector	No
Ambient Temperature	40 °C	Drive End Bearing Size	6203
Opp Drive End Bearing Size	6203	UL	Recognized
CSA	Y	CE	N
IP Code	22		

Technical Specifications

Electrical Type	Split Phase	Starting Method	Across The Line
Poles	4	Rotation	Selective Counterclockwise
Mounting	Resilient Base	Motor Orientation	HORIZONTAL
Drive End Bearing	BALL	Opp Drive End Bearing	BALL
Frame Material	Rolled Steel	Shaft Type	NEMA 56
Overall Length	12.32 in	Frame Length	6.50 in
Shaft Diameter	0.625 in	Shaft Extension	1.88 in
Assembly/Box Mounting	F1 ONLY		
Outline Drawing	029056-650	Connection Diagram	005203.01

4

3

Uncontrolled Copy

2

1

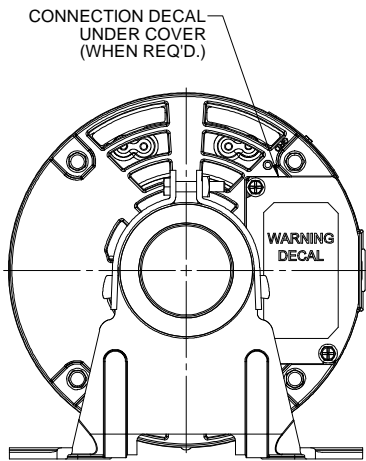

1/2-14 NPT (PLUGGED)

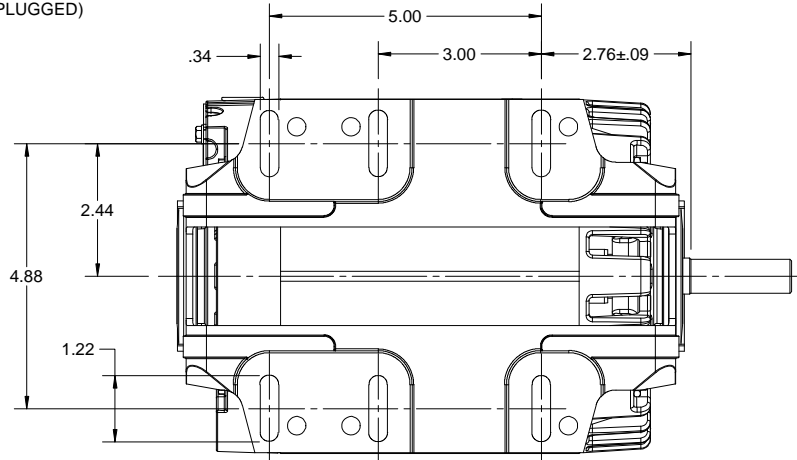
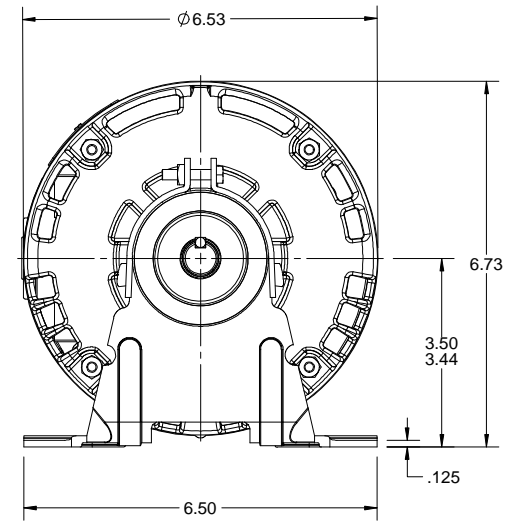
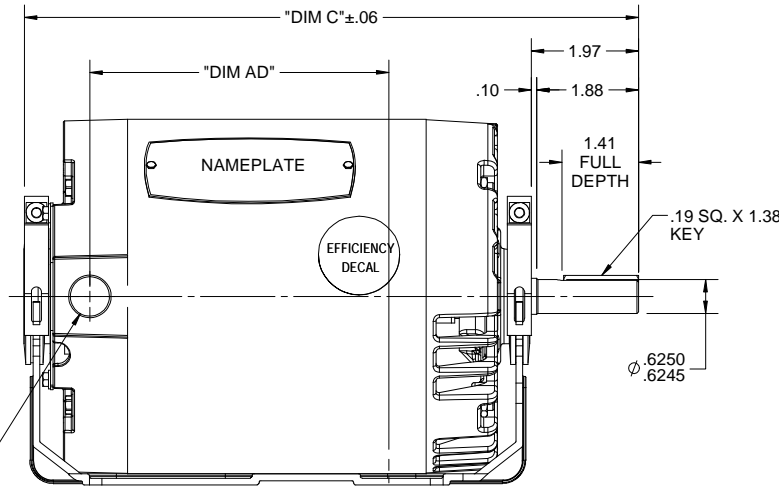

DASH NO.	"DIM C"	"DIM AD"
-550	11.29	5.50
-600	11.79	6.00
-650	12.29	6.50
-700	12.79	7.00
-750	13.29	7.50

DRAWING REVISION A	REVISION BY P. GASSER	DATE 07/27/2017
ECO ECO-0128249	APPROVED BY	DATE
ECO DESCRIPTION RELEASED FOR PRODUCTION		
<small>COPYRIGHT REGAL BELOIT AMERICA, INC. ALL RIGHTS RESERVED. PROPRIETARY AND CONFIDENTIAL INFORMATION - THIS DOCUMENT IS THE PROPERTY OF REGAL BELOIT AMERICA, INC. ("OWNER") AND CONTAINS OWNER'S PROPRIETARY INFORMATION. ANY PERSON, CORPORATION OR OTHER FIRM RECEIVING IT IS DEEMED, BY RECEIVING IT, TO AGREE THAT IT, AND/OR ANY PART OF IT, SHALL NOT BE DISCLOSED TO ANY PERSON, CORPORATION OR OTHER ENTITY, DUPLICATED, AND/OR USED, EXCEPT AS EXPRESSLY APPROVED IN WRITING IN ADVANCE BY OWNER. THIS DOCUMENT SHALL BE RETURNED TO OWNER UPON REQUEST. IT MAY BE SUBJECT TO CERTAIN RESTRICTIONS UNDER APPLICABLE EXPORT CONTROL LAWS AND REGULATIONS.</small>		

TOLERANCES UNLESS OTHERWISE SPECIFIED:			
DEC.	INCH	mm	ANGLE
.X	±0.1	[±2.5]	±0.5°
.XX	±0.03	[±0.76]	
.XXX	±0.005	[±0.127]	
.XXXX	±0.0005	[±0.0127]	
REMOVE BURRS & BREAK SHARP			
EDGES: .003/.015 [.076/.381] X 45°			
CORNER FILLETS: R.02 [.51]			
MACHINED SURFACES: 125/3.2			
mm SHOWN IN [BRACKETS]			

DRAWN BY P. GASSER
DATE 07/21/2017
APPROVED BY
DATE
REFERENCE
THIRD ANGLE PROJECTION

 Regal Beloit America, Inc.	
DESCRIPTION OUTLINE 56-FRAME, DRIP PROOF	
MATERIAL	PROCESS/FINISH
SIZE B	DRAWING NUMBER 029056
	SHEET 1 OF 1

4

3

2

1

VIEW FROM OUTSIDE OF MOTOR AT SWITCH END.

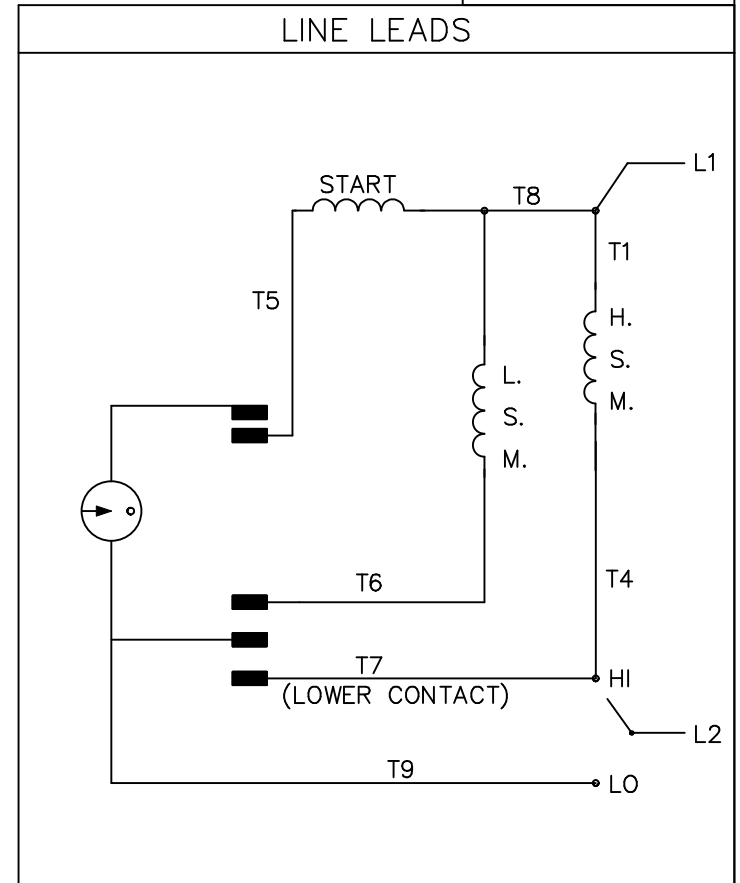
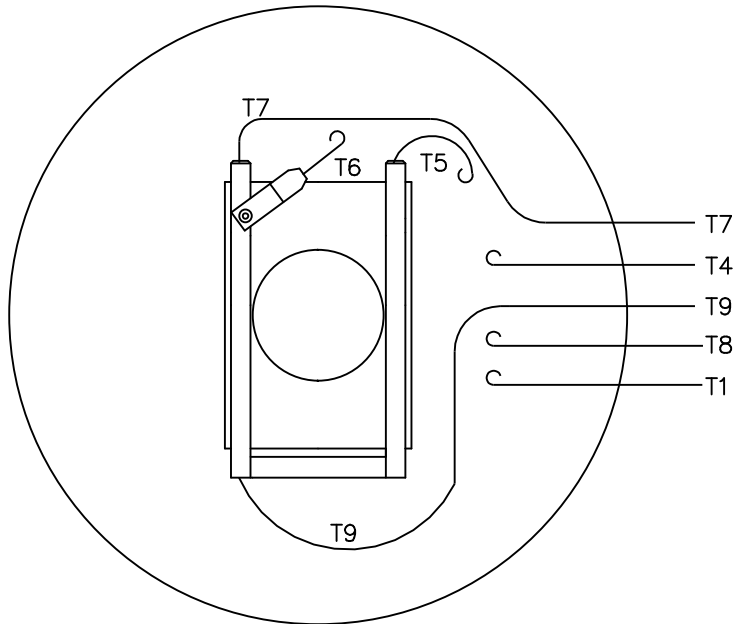

ROTATION FACING LEAD END	L1	L2	
		HI SPEED	LOW SPEED
C.C.W.	T1, T8	T4, T7	T9
C.W.	T4, T8	T1, T7	T9

				TOLERANCES UNLESS OTHERWISE SPECIFIED		LEESON ELECTRIC CORPORATION			
				DECIMALS					
				.00	± .01	DRAWN PG 10/21/83	TITLE EXTERNAL WIRING DIAGRAM		
				.000	± .005	CH'K'D. TEM	TYPE "S" W/O PROTECTOR		
02	REDRAWN ON CAD	DBT	06/09/97	.0000	± .0005	APPR. 10/21/83	MAT'L. DECAL - 080092		
NO.	REVISION	BY	DATE	FRACTIONS	± 1/64	SCALE 1=1	SPLIT PHASE		
THIS DRAWING IN DESIGN AND DETAIL IS OUR PROPERTY AND MUST NOT BE USED EXCEPT IN CONNECTION WITH OUR WORK ALL RIGHTS OF DESIGN AND INVENTION ARE RESERVED				ANGLES	± 1/2°	REF. 005192	FINISH	SIZE	DRAWING NO.
				INCH/MM		FMF W555(4-6)1	65460B1	A	005203-01



LEESON ELECTRIC CORPORATION
TYPICAL PERFORMANCE CURVE for AC MOTOR

Model No 113643.00

Catalog No 113643.00

Curve at 230 Volts HP 0.5&0.22 PHASE 1
60 HZ
0.5 HP VOLTS 230&230

HZ 60&60 RPM 1725&1140

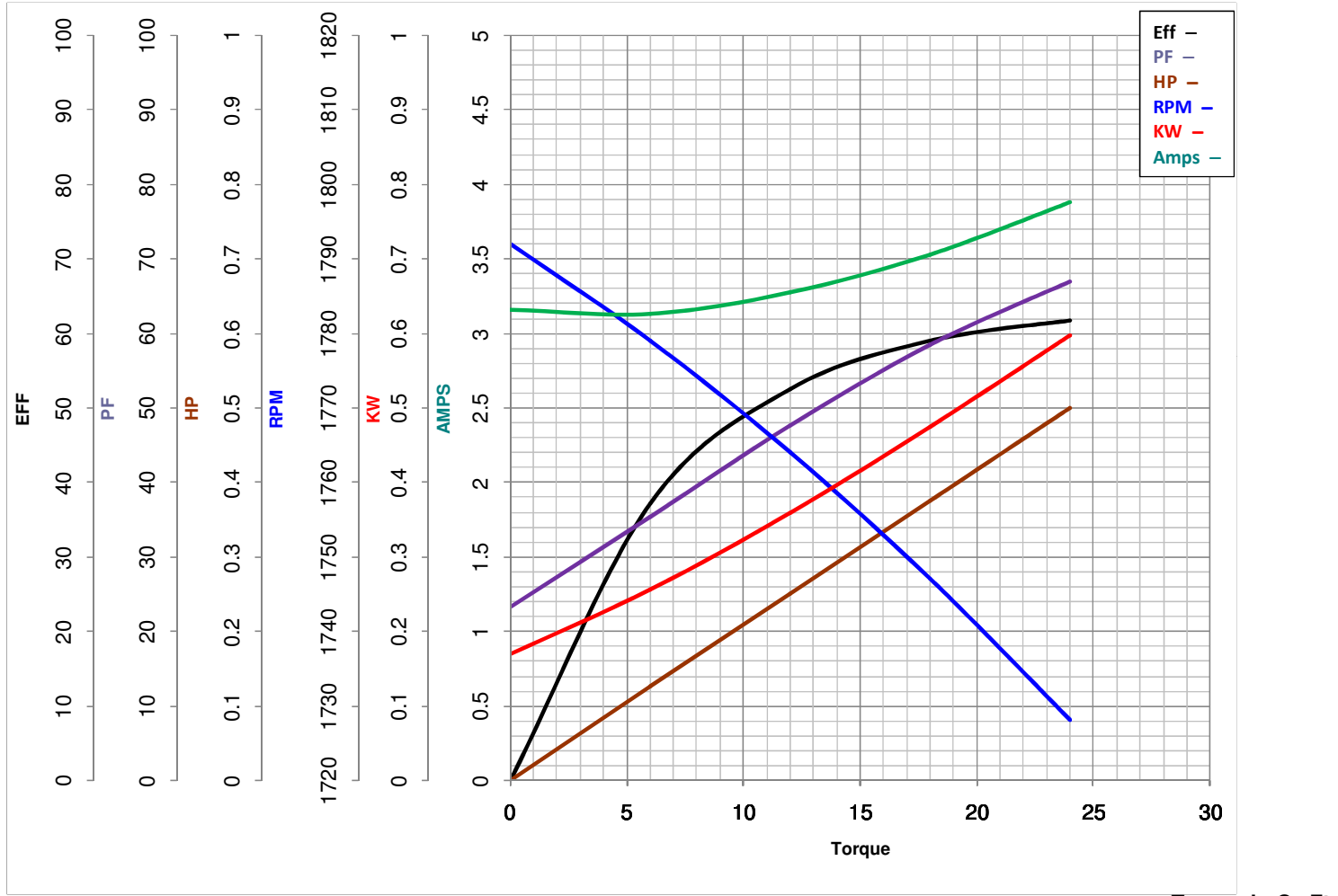

FL TORQUE	<u>24</u>	Oz.Ft	FL AMPS	<u>3.9</u>	
BD TORQUE	<u>62.7</u>	Oz.Ft	PU TORQUE	<u>49.4</u>	Oz.Ft
LR TORQUE	<u>43.36</u>	Oz.Ft	LR AMPS	<u>22.23</u>	
WINDING	S63(4-6)15-2		Date	<u>7/16/2018</u>	