

PRODUCT INFORMATION PACKET



Model No: C6C17WB2M

Catalog No: 112432.00

3/4HP..1725RPM.56.TEFC./V.1PH.60HZ.CONT.NOT.40C.1.15SF.RIGID.WASHGUARD.C6C17WB2M

General Purpose



Regal and Leeson are trademarks of Regal Beloit Corporation or one of its affiliated companies.

©2018 Regal Beloit Corporation, All Rights Reserved. MC017097E





Nameplate Specifications

Output HP	0.75 Hp	Output KW	0.56 kW
Frequency	60 Hz	Voltage	115/208-230 V
Current	10.8/5.4 A	Speed	1725 rpm
Service Factor	1.15	Phase	1
Efficiency	70 %	Duty	Continuous
Insulation Class	F	Design Code	N
KVA Code	L	Frame	56
Enclosure	Totally Enclosed Fan Cooled	Overload Protector	No
Ambient Temperature	40 °C	Drive End Bearing Size	6205
Opp Drive End Bearing Size	6203	UL	Recognized
CSA	Y	CE	N
IP Code	55		

Technical Specifications

Electrical Type	Capacitor Start Induction Run	Starting Method	Across The Line
Poles	4	Rotation	Selective Counterclockwise
Mounting	Rigid base	Motor Orientation	HORIZONTAL
Drive End Bearing	BALL	Opp Drive End Bearing	BALL
Frame Material	Rolled Steel	Shaft Type	NEMA 56
Overall Length	11.25 in	Frame Length	5.75 in
Shaft Diameter	0.625 in	Shaft Extension	1.88 in
Assembly/Box Mounting	F1 ONLY		
Outline Drawing	607-0011-575B	Connection Diagram	005278.07

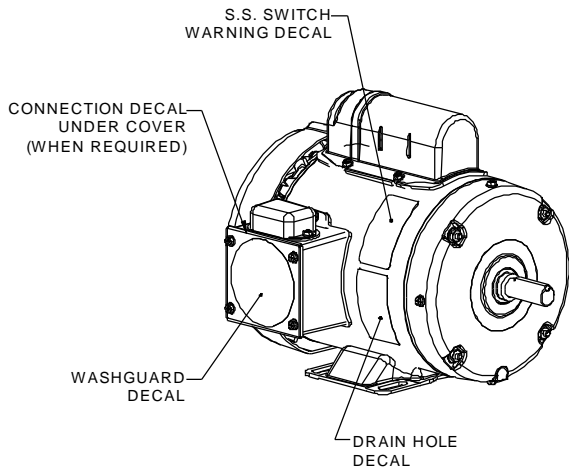
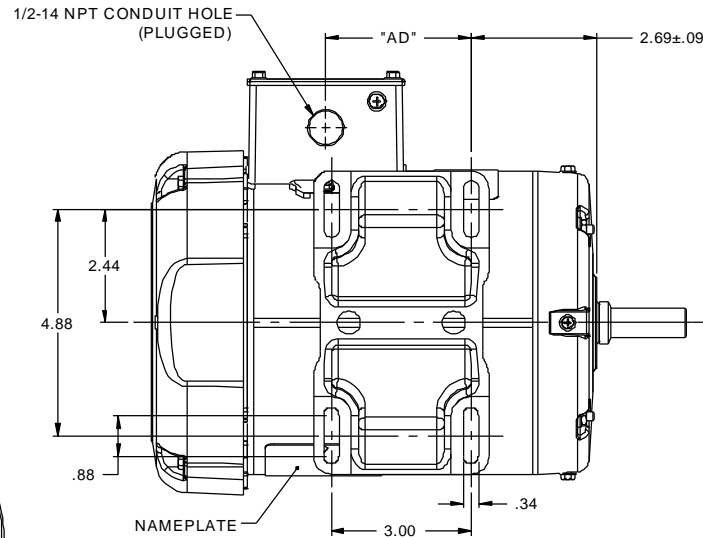
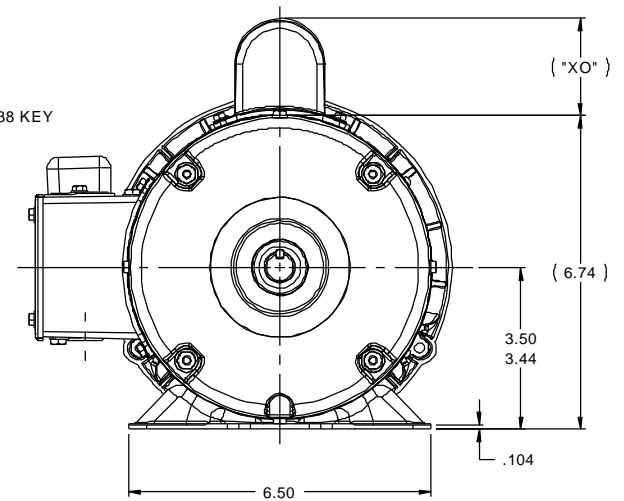
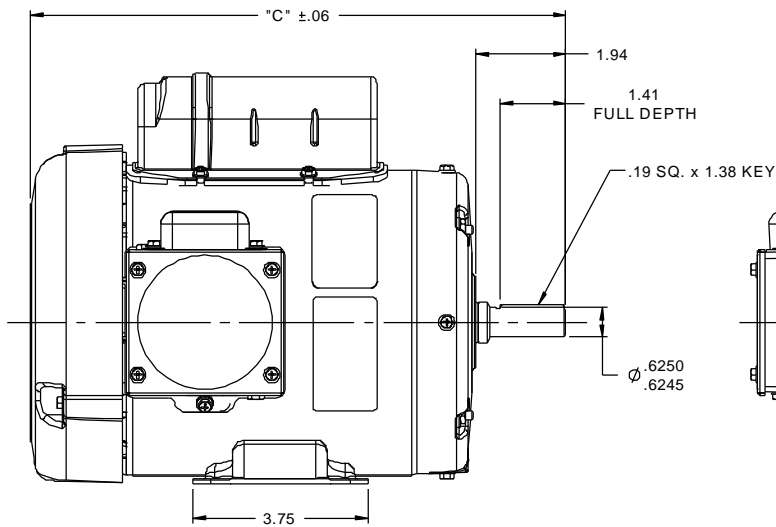
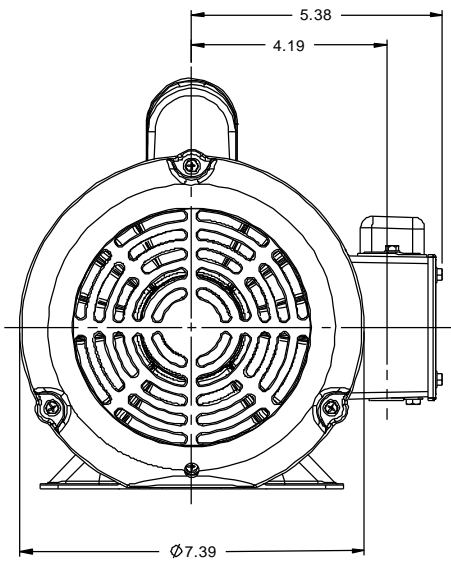

WASHGUARD MOTOR

- SPECIAL FEATURES:
1. SHAFT SEALS & V-RING.
 2. PLUGGED DRAIN HOLES IN ENDBELLS & CONDUIT BOX.
 3. BUNA-N GASKETS THROUGHOUT.
 4. STAINLESS STEEL SHAFT, HARDWARE & NAMEPLATE.
 5. SOLID STATE SWITCH MOUNTED TO CONDUIT BOX.

DASH NO.	"C"	"AD"	"XO"
450A	10.00	1.63	2.00
475A	10.25	1.88	2.00
500A	10.50	2.13	2.00
525A	10.75	2.38	2.00
550A	11.00	2.63	2.00
575A	11.25	2.88	2.00
600A	11.50	3.13	2.00
625A	11.75	3.38	2.00
650A	12.00	3.63	2.00

DASH NO.	"C"	"AD"	"XO"
450B	10.00	1.63	2.25
475B	10.25	1.88	2.25
500B	10.50	2.13	2.25
525B	10.75	2.38	2.25
550B	11.00	2.63	2.25
575B	11.25	2.88	2.25
600B	11.50	3.13	2.25
625B	11.75	3.38	2.25
650B	12.00	3.63	2.25

TOLERANCES UNLESS SPECIFIED	
DEC	INCHES
X	±.1
XX	±.03
XXX	±.005
XXXX	±.0005
NO	±1/2°



ELECTRIC MOTORS
GEARMOTORS
AND DRIVES

DRAWN PG 02/10/11
CHK
APPR
SCALE 3:8
REF 028880
FMF 112431.00
PAGE OF

TITLE OUTLINE - 56 FRAME
TEFC - RIGID
MAT'L WASHGUARD

NO	REVISION	BY & DATE	CHK	ANG	FINISH	PREV	SIZE	DRAWING NO	REV
			RFP				B	607-0011	



NETWORK FILE NAME 607-0011

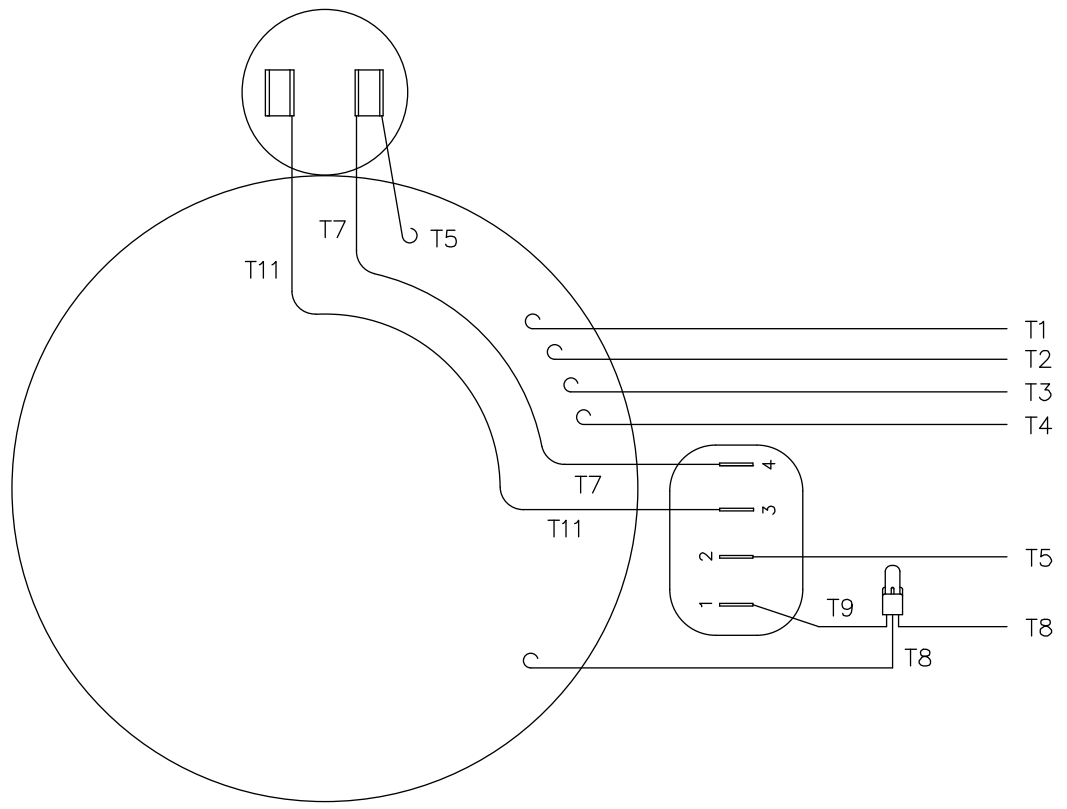

VIEW FROM OUTSIDE OF MOTOR AT SWITCH END.

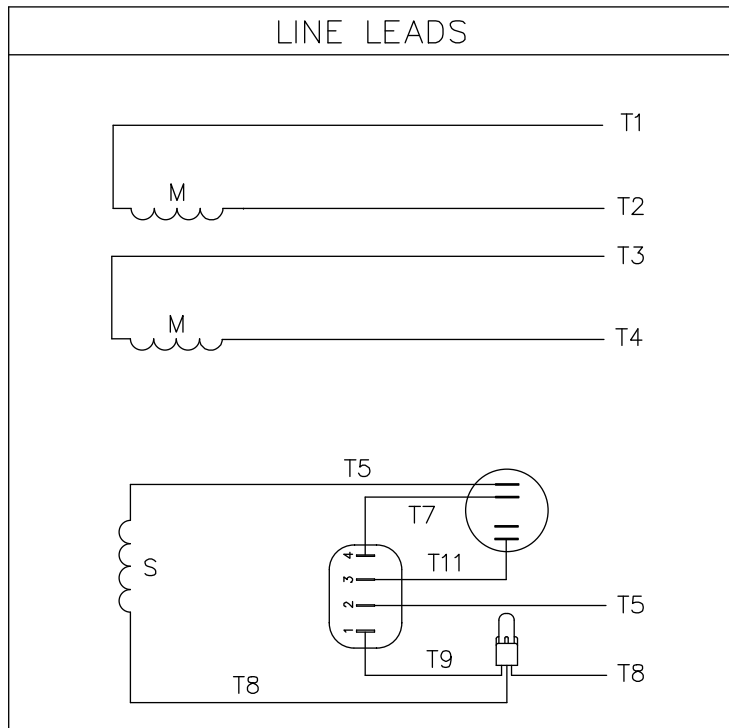

	ROTATION FACING LEAD END	L1	L2	JOIN & INSULATE
HIGH VOLT	C.C.W.	T1	T4 T5	T2, T3 T8
	C.W.	T1	T4 T8	T2, T3 T5
LOW VOLT	C.C.W.	T1, T3 T8	T2, T4 T5	
	C.W.	T1, T3 T5	T2, T4 T8	

				TOLERANCES UNLESS OTHERWISE SPECIFIED		LEESON ELECTRIC CORPORATION				
				DECIMALS						
				.00	± .01	DRAWN	TITLE			
				.000	± .005	CH'K'D.	EXTERNAL WIRING DIAGRAM TYPE "C" W/O PROTECTOR			
01	ADDED DECAL FOR STOCK MOTORS ECR 0042509	GWS	9/10/13	.0000	± .0005	APPR.	MAT'L. DECAL - 004012			
NO.	REVISION	BY	DATE	FRACTIONS	± 1/64	SCALE	STOCK MOTORS TO USE DECAL 214-0122-001			
THIS DRAWING IN DESIGN AND DETAIL IS OUR PROPERTY AND MUST NOT BE USED EXCEPT IN CONNECTION WITH OUR WORK ALL RIGHTS OF DESIGN AND INVENTION ARE RESERVED				ANGLES	± 1/2*	REF.	FINISH		SIZE	DRAWING NO.
				INCH/MM		FMF	STANDARD		A	005278-07

