

PRODUCT INFORMATION PACKET



Model No: C4T17NK2A

Catalog No: 102919.00

..1/2HP..1725RPM.S56C.TENV.208-230/460V.3PH.60HZ.CONT.40C.1.15SF.RIGID.C4T17NK2A.....WP 56 to 48 Repl 110913.NOT.....

Totally Enclosed Non-Ventilated (TENV)



Regal and Leeson are trademarks of Regal Beloit Corporation or one of its affiliated companies.

©2018 Regal Beloit Corporation, All Rights Reserved. MC017097E





Nameplate Specifications

Output HP	0.50 Hp	Output KW	0.37 kW
Frequency	60 Hz	Voltage	208-230/460 V
Current	1.8-1.8/0.90 A	Speed	1725 rpm
Service Factor	1.15	Phase	3
Efficiency	77 %	Duty	Continuous
Insulation Class	B	Design Code	NO DESIGN CODE
KVA Code	M	Frame	S56C
Enclosure	Totally Enclosed Non Ventilated	Overload Protector	No
Ambient Temperature	40 °C	Drive End Bearing Size	6203
Opp Drive End Bearing Size	6203	UL	Recognized
CSA	Y	CE	N
IP Code	43		

Technical Specifications

Electrical Type	Squirrel Cage Induction Run	Starting Method	Across The Line
Poles	4	Rotation	Reversible
Mounting	Rigid base	Motor Orientation	HORIZONTAL
Drive End Bearing	BALL	Opp Drive End Bearing	BALL
Frame Material	Rolled Steel	Shaft Type	T
Overall Length	10.06 in	Frame Length	6.00 in
Shaft Diameter	0.625 in	Shaft Extension	1.88 in
Assembly/Box Mounting	F1 ONLY		
Outline Drawing	031766-600	Connection Diagram	005010.01

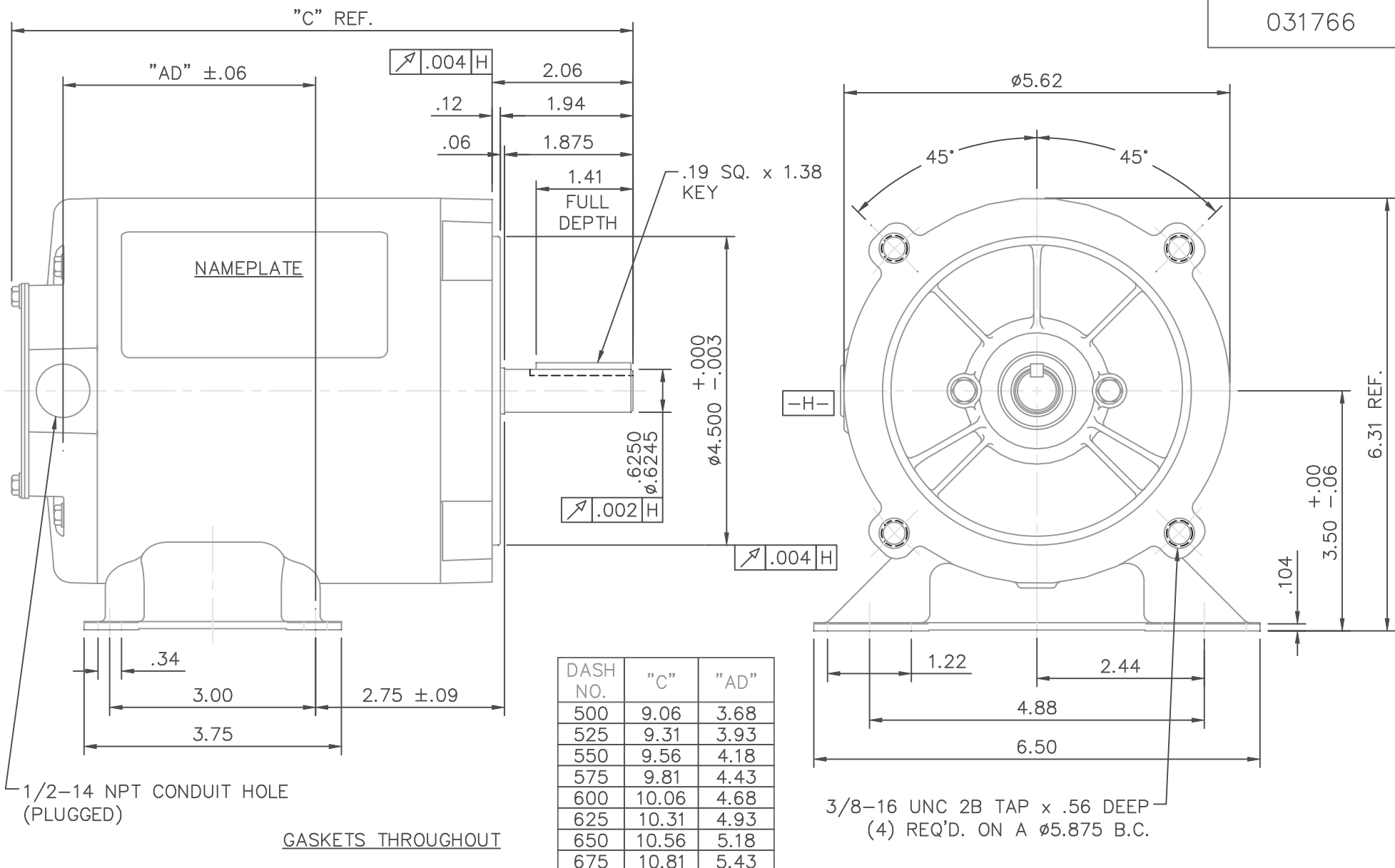

DASH NO.	"C"	"AD"
500	9.06	3.68
525	9.31	3.93
550	9.56	4.18
575	9.81	4.43
600	10.06	4.68
625	10.31	4.93
650	10.56	5.18
675	10.81	5.43

TOLERANCES UNLESS SPECIFIED	
DEC.	INCHES
.X	±.1
.XX	±.03
.XXX	±.005
.XXXX	±.0005
ANG	±1/2°



ELECTRIC MOTORS
GEARMOTORS
AND DRIVES

DRAWN	PG 3/30/04
CHK	
APPD	
SCALE	1=2
REF	031629
FMF	102919.00
PREV	

TITLE	OUTLINE - S56C FRAME RIGID "C" FACE - TENV
MAT'L.	3 PHASE
FINISH	

THIS DRAWING IN DESIGN AND DETAIL IS OUR PROPERTY AND MUST NOT BE USED EXCEPT IN CONNECTION WITH OUR WORK ALL RIGHTS OF DESIGN AND INVENTION ARE RESERVED THIS IS AN ELECTRONICALLY GENERATED DOCUMENT - DO NOT SCALE THIS PRINT

RFP	CAD FILE	031766	SIZE	DRAWING NO.	REV.
DIST			A	031766	

005010-01

VIEW FROM OUTSIDE OF MOTOR AT SWITCH END.



VOLTAGE	L1	L2	L3	JOIN & INSULATE
HIGH	T1	T2	T3	(T4,T7) (T5,T8) (T6,T9)
LOW	T1,T7	T2,T8	T3,T9	T4,T5,T6

				TOLERANCES UNLESS SPECIFIED		Regal Beloit America, Inc.		DRAWN RDW 04/12/02				
				DEC.	INCHES			CHK				
				.X	±.1			APPD				
				.XX	±.01			SCALE 1=1				
				.XXX	±.005	TITLE		REF FIG.2-51				
A	UPDATED TO REGAL LOGO			SAJ	06/26/15	AJY	.XXXX	±.0005	MAT'L. DECAL - 004014	FMF		
NO.	REVISION			BY & DATE	CHK	ANG	±1/2"	FINISH	PREV			
THIS DRAWING IN DESIGN AND DETAIL IS OUR PROPERTY AND MUST NOT BE USED EXCEPT IN CONNECTION WITH OUR WORK ALL RIGHTS OF DESIGN AND INVENTION ARE RESERVED THIS IS AN ELECTRONICALLY GENERATED DOCUMENT - DO NOT SCALE THIS PRINT				RFP	04/12/02		CAD FILE	00501001		SIZE	DRAWING NO.	REV.
				DIST	BRF-NLV				A	005010-01		A



CERTIFICATION DATA SHEET

1051 CHEYENNE AVE.
 GRAFTON, WI 53024
 PH. 262-377-8810

CATALOG #: 102919.00

CONN. DIAGRAM: 005010.01

OUTLINE: 031766-600

MOUNTING: F1 ONLY

WINDING #: TE48453 NR 3 D

TYPICAL MOTOR PERFORMANCE DATA

HP	KW	SYNC. RPM	F.L. RPM	FRAME	ENCLOSURE	KVA CODE	DESIGN
1/2	0.37	1800	1725	S56C	TENV	M	NO DESIGN CODE

PH	Hz	VOLTS	AMPS	START TYPE	DUTY	INSL	S.F.	AMB°C
3	60	208-230/460	1.8-1.8/.9	ACROSS THE LINE	CONTINUOUS	B3	1.15	40

FULL LOAD EFF:	77	3/4 LOAD EFF:	73.8	1/2 LOAD EFF:	66.9	GTD. EFF	ELEC. TYPE
FULL LOAD PF:	69	3/4 LOAD PF:	60.2	1/2 LOAD PF:	47.5	0	SQ CAGE IND RUN

F.L. TORQUE	LOCKED ROTOR AMPS	L.R. TORQUE	B.D. TORQUE	F.L. RISE°C		
24 OZ-FT	12.6 / 6.3	91.4 OZ-FT	381 %	98 OZ-FT	408 %	-

SOUND PRESSURE @ 3 FT.	SOUND POWER	ROTOR WK^2	MAX. WK^2	SAFE STALL TIME	STARTS / HOUR	APPROX. MOTOR WGT
0 DBA	10 DBA	0.053 LB-FT^2	0 LB-FT^2	10 SEC.	0	0 LBS.

*** SUPPLEMENTAL INFORMATION ***

DE BRACKET TYPE	ODE BRACKET TYPE	MOUNT TYPE	ORIENTATION	SEVERE DUTY	HAZARDOUS LOCATION	DRIP COVER	SCREENS	PAINT
C-FACE	STANDARD	RIGID	HORIZONTAL	FALSE	NONE	FALSE	NONE	BLUE - LEESON (ENAMEL)

BEARINGS DE ODE	GREASE	SHAFT TYPE	SPECIAL DE	SPECIAL ODE	SHAFT MATERIAL	FRAME MATERIAL
BALL BALL	MULTEMP SRL	T	NONE	NONE	1144 STRESSPROOF (C-223)	ROLLED STEEL

THERMO-PROTECTORS				THERMISTORS	CONTROL	SPACE HEATERS
TERMOSTATS	PROTECTORS	WDG RTDS	BRG RTDS	NONE	FALSE	NONE
NONE	NOT	NONE	NONE	NONE	FALSE	NONE

* INVERTER TORQUE: NONE
 INV. HP SPEED RANGE: NONE

ENCODER:	NONE	NONE	PPR
BRAKE:	NONE	NONE	NONE
FT-LB	NONE	V	NONE
FT-LB	NONE	NONE	Hz

N
 O
 T
 E
 S

Data Sheet

Date: 1/18/2018

102919.00



Data @ 460 V

Motor Load Data								
Load	0%	25%	50%	75%	100%	115%	125%	LR
Current (Amps)	0.65	0.69	0.72	0.80	1.00	1.05	1.10	6.3
Torque (ft-lb)	0.00	94.5	186	289	383	447	450	1,459
RPM	1800	1787	1774	1760	1747	1,735	1,737	0
Efficiency (%)		51.9	66.9	73.8	76.5	76.5	77.6	
P.F. (%)	22.8	33.1	47.5	60.2	69.1	70.0	73.8	0.0

Motor Speed Data							Information Block																					
	LR	Pull-Up	BD	Rated	Idle		HP	Sync. RPM	Frame	Enclosure	Construction	Voltage	Frequency	Design	LR Code letter	Service Factor	Temp Rise @ FL	Duty	Ambient	Elevation	Rotor/Shaft wk ²	Ref Wdg	Sound Pressure @ 1M	VFD Rating	Outline Dwg	Conn. Diag	Additional Specifications:	
Speed (RPM)	0	900	1656	1747	1800		0.5	1800	48	TENV	TTR	208-230/460	60	B	M	1.0	81	CONT	40	1,000	0.05	TE48453 NR	0	NONE	031766-600	005010.01		
Current (Amps)	6.3	5.8	3.8	1.00	0.55							V	Hz				°C		°C	feet	LB-Ft ²	dB(A)						
Torque (ft-lb)	1,459	1,213	1,565	383	0.00																							

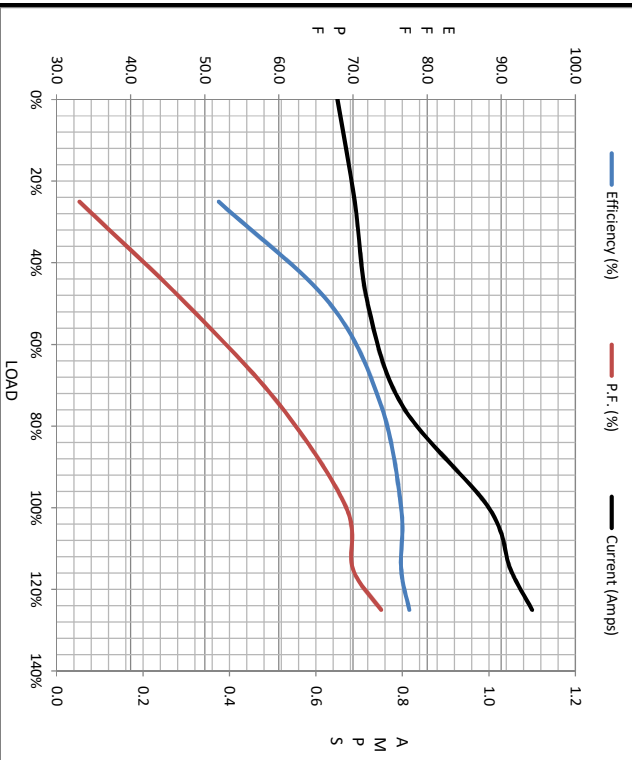

EQUIV CKT (OHMS / PHASE)				
R1	R2	X1	X2	Xm
0.0000	0.0000	0.0000	0.0000	0.0000

