

PRODUCT INFORMATION PACKET



Model No: 056C17D2101

Catalog No: X601

Other Purpose Motor, 0.33 HP, 1 Ph, 60 Hz, 115/208-230 V, 1800 RPM, 56Z Frame, DP



Regal and LEESON are trademarks of Regal Rexnord Corporation or one of its affiliated companies.
©2025 Regal Rexnord Corporation, All Rights Reserved. MC017097E





Nameplate Specifications

Phase	1	Output HP	0.33 Hp
Output KW	0.25 kW	Voltage	115/208-230 V
Speed	1725 rpm	Service Factor	1.35
Frame	56Z	Enclosure	Drip Proof
Thermal Protection	Automatic	Efficiency	62 %
Ambient Temperature	40 °C	Frequency	60 Hz
Current	5.8/2.8-2.9 A	Power Factor	64
Duty	Continuous	Insulation Class	B
Design Code	NO DESIGN CODE	KVA Code	K
Drive End Bearing Size	6203	Opp Drive End Bearing Size	6203
UL	Recognized	CSA	Y
CE	N	IP Code	22
Number of Speeds	1		

Technical Specifications

Electrical Type	Capacitor Start Induction Run	Starting Method	Across The Line
Poles	4	Rotation	Fixed Counterclockwise
Resistance Main	0 Ohms	Mounting	Resilient Base
Motor Orientation	Horizontal	Drive End Bearing	Ball
Opp Drive End Bearing	Ball	Frame Material	Rolled Steel
Shaft Type	Single Special Extension	Overall Length	14.41 in
Frame Length	6.75 in	Shaft Diameter	0.625 in
Shaft Extension	5.66 in	Assembly/Box Mounting	F1 ONLY
Connection Drawing	A-EE9104A	Outline Drawing	A-SS400109-675

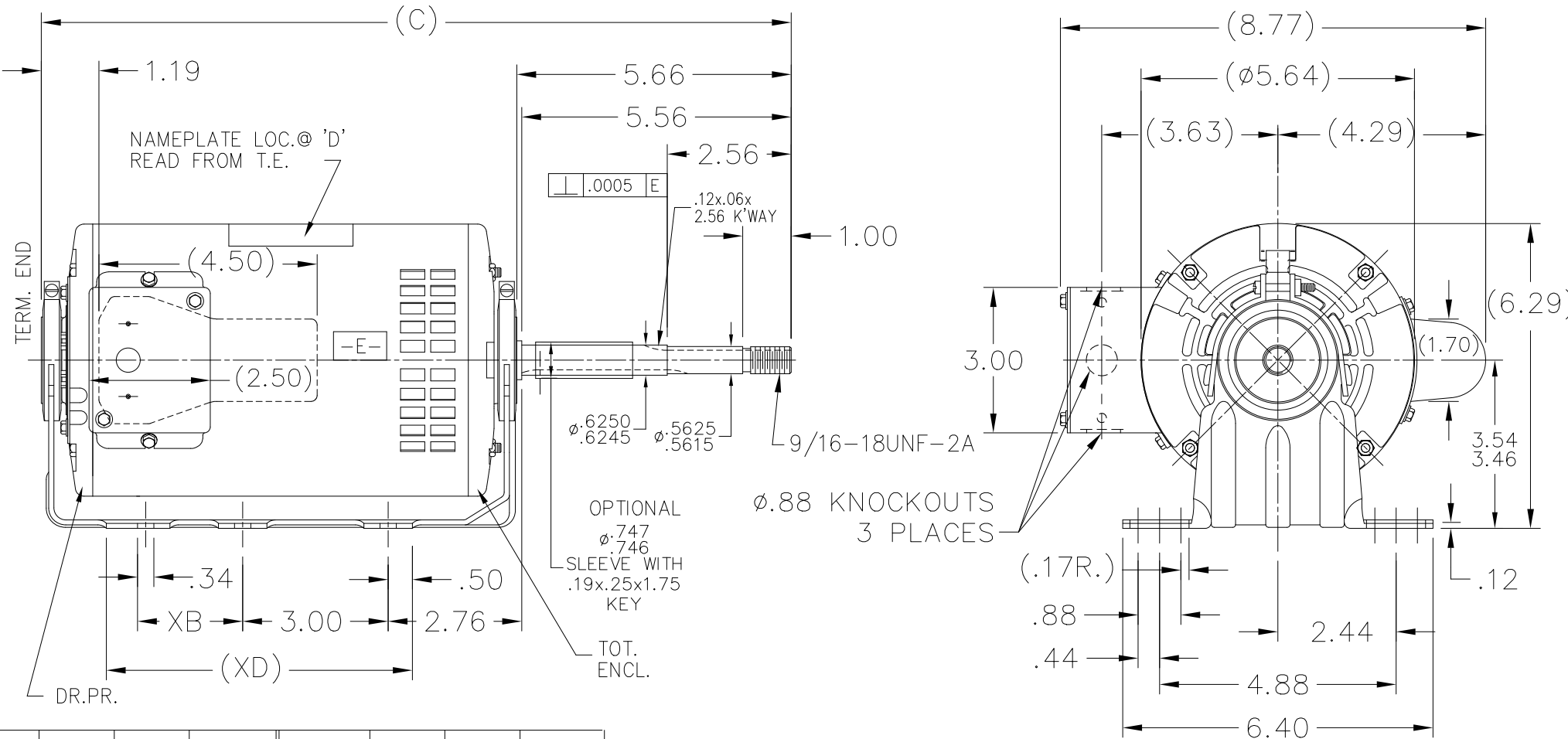

DASH	XB	XD	C	DASH	XB	XD	C
625	0	4.81	13.91	725	2.00	5.81	14.91
650	0	5.06	14.16	750	2.00	6.06	15.16
675	0	5.31	14.41	775	2.00	6.31	15.41
700	2.00	5.56	14.66				

NO.	REVISION	BY & DATE	CHK	ANG	TOLERANCES UNLESS SPECIFIED	
					DEC.	INCHES
5	CHANGED DRAWING TEMPLATE TO RRX PER ECR-0233449	KVDG 05-29-2024	DS	DEC.	INCHES	
4	CHANGED CONDUIT BOX PER CN39440-6	TJW		.X	±.1	
3	CHANGED C'BOX PER CN39440-5	TJW 9/5/2006	ML	.XX	±.03	
2	REVISED ODE BRACKET AND SHAFT EXT. CN 37313	RDH 12-08-2003	JET	.XXX	±.005	
1	NEW DRAWING	4274145 MRB 05/01/1995	ML	.XXXX	±.0005	
					±'7'30"	

Regal Rexnord Regal Beloit America, Inc.

TITLE OUTLINE 48/56 FR. RESILIENT BASE
SPL EXT. STOCK LAUNDRY MOTOR

MAT'L.

FINISH

DRAWN MRB 04/24/1995
CHK ML 04/25/1995
APPD GK 04/25/1995
SCALE 5=16
REF SS73788
FMF CN 37313
PREV

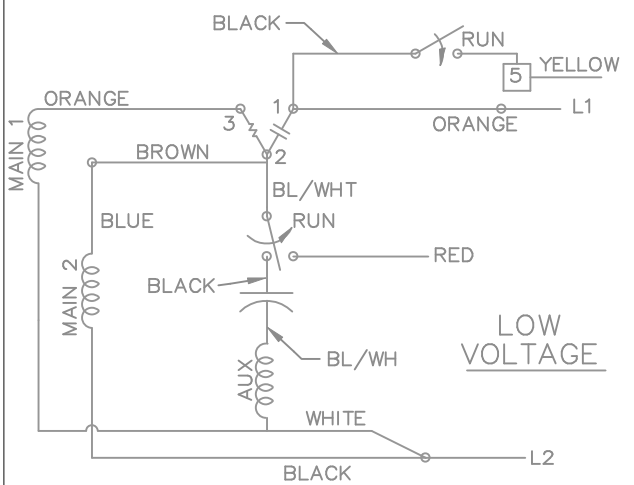

LOW VOLTAGE

AT MOTOR RUNNING CONDITION CONTACTS ARE:
 . NORMALLY CLOSED BETWEEN PROTECTOR AND RED JUMPER
 . NORMALLY OPEN BETWEEN PROTECTOR AND CAPACITOR

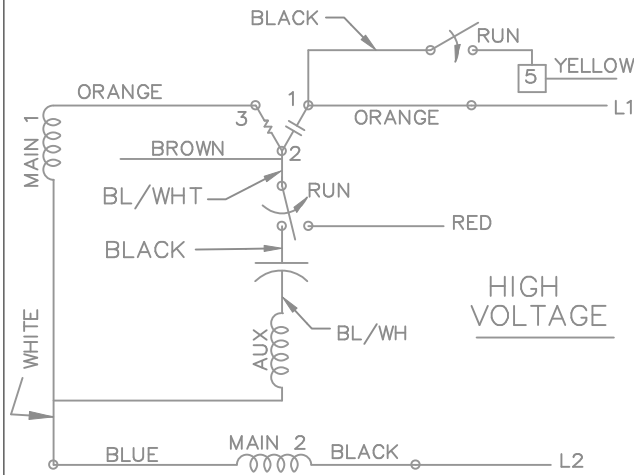

HIGH VOLTAGE

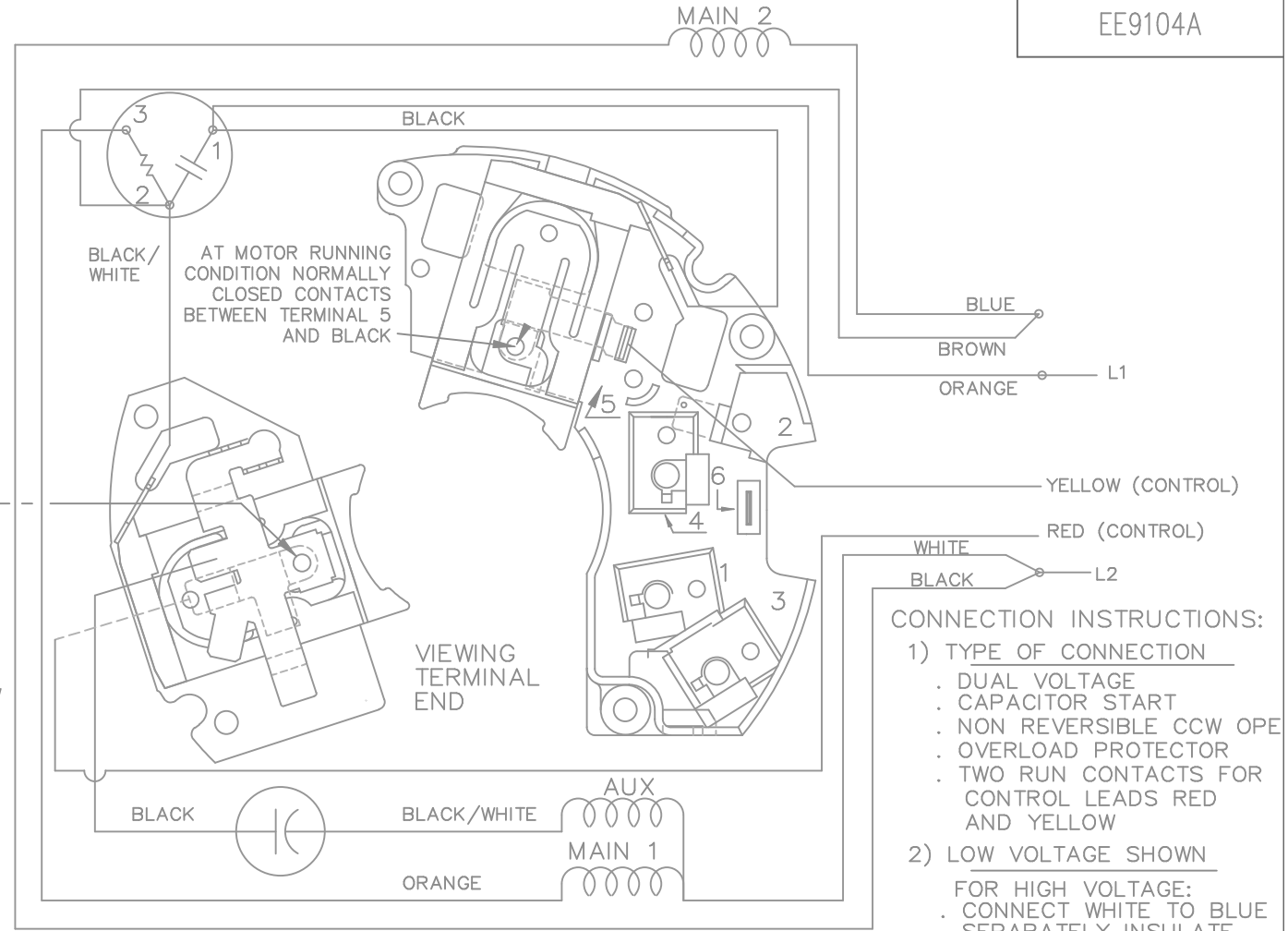

AT MOTOR RUNNING CONDITION NORMALLY CLOSED CONTACTS BETWEEN TERMINAL 5 AND BLACK

VIEWING TERMINAL END

CCW ROTATION-LEAD END

NOTE:
 DASH LINES INDICATE LEADS CONNECTED TO MOTOR SIDE OF SWITCH.

- CONNECTION INSTRUCTIONS:
- 1) TYPE OF CONNECTION
 - . DUAL VOLTAGE
 - . CAPACITOR START
 - . NON REVERSIBLE CCW OPE
 - . OVERLOAD PROTECTOR
 - . TWO RUN CONTACTS FOR CONTROL LEADS RED AND YELLOW
 - 2) LOW VOLTAGE SHOWN

FOR HIGH VOLTAGE:

 - . CONNECT WHITE TO BLUE
 - . SEPARATELY INSULATE BROWN
 - 3) CAUTION
 - . LINE VOLTAGE APPEARS BETWEEN L2 AND YELLOW AND RED LEADS WHEN MOTOR IS AT RUNNING SPEED

				TOLERANCES UNLESS SPECIFIED		REGAL-BELOIT <i>Motor Technologies Group</i>	DRAWN				
				DEC.	INCHES		MKLEIST	09-22-03			
				.X	±.1	TITLE CONNECTION DIAGRAM 48 FRAME DUAL VOLTAGE (REPLACES A-EE9061J)	CHK	ML 09-25-03			
				.XX	±.02		APPD	DN 09-25-03			
2	REVISED TO MATCH WINDING DIAGRAM CN 37313	RDH 12-18-2003	JET	.XXX	±.005	SCALE	1=1				
1	NEW DRAWING	MJK 09/22/2003		.XXXX	±.0005	REF					
NO.	REVISION	BY & DATE	CHK	ANG	±7'30"	FINISH	FMF				
THIS DRAWING IN DESIGN AND DETAIL IS OUR PROPERTY AND MUST NOT BE USED EXCEPT IN CONNECTION WITH OUR WORK ALL RIGHTS OF DESIGN AND INVENTION ARE RESERVED THIS IS AN ELECTRONICALLY GENERATED DOCUMENT - DO NOT SCALE THIS PRINT				RFP		CAD FILE ee9104a	SIZE	DRAWING NO. EE9104A	PAGE	OF	REV.
				DIST			A				2

CERTIFICATION DATA SHEET

Model#: 56C17D2101 L
CONN. DIAGRAM: A-EE9104A
OUTLINE: A-SS400109-675

WINDING#: CE4843 NONE 3
ASSEMBLY: F1 ONLY

TYPICAL MOTOR PERFORMANCE DATA

HP	KW	SYNC. RPM	F.L. RPM	FRAME	ENCLOSURE	KVA CODE	DESIGN
1/3	0.25	1800	1725	56Z	DP	K	NO DESIGN CODE

PH	Hz	VOLTS	FL AMPS	START TYPE	DUTY	INSL	S.F	AMB°C	ELEVATION
1	60	115/208-230	5.8/2.8-2.9	ACROSS THE LINE	CONTINUOUS	B3	1.35	40	3300

FULL LOAD EFF: 62	3/4 LOAD EFF: -	1/2 LOAD EFF: -	GTD. EFF	ELEC. TYPE	NO LOAD AMPS
FULL LOAD PF: 64	3/4 LOAD PF: -	1/2 LOAD PF: -	-	CAP START IND RUN	4.3 / 2.1

F.L. TORQUE	LOCKED ROTOR AMPS	L.R. TORQUE	B.D. TORQUE	F.L. RISE°C
16.3 LB-FT	19.4 / 9.7	35.5 LB-FT -	33.9 LB-FT 208	40

SOUND PRESSURE @ 3 FT.	SOUND POWER	ROTOR WK^2	MAX. WK^2	SAFE STALL TIME	STARTS /HOUR	APPROX. MOTOR WGT
- dBA	- dBA	- LB-FT^2	- LB-FT^2	- SEC.	-	- LBS.

***** SUPPLEMENTAL INFORMATION *****

DE BRACKET TYPE	ODE BRACKET TYPE	MOUNT TYPE	ORIENTATION	SEVERE DUTY	HAZARDOUS LOCATION	DRIP COVER	SCREENS	PAINT
STANDARD	STANDARD	RESILIENT BASE	HORIZONTAL	FALSE	NONE	FALSE	NONE	GRAY (POWDER)

BEARINGS		GREASE	SHAFT TYPE	SPECIAL DE	SPECIAL ODE	SHAFT MATERIAL	FRAME MATERIAL
DE	OPE						
BALL	BALL	MULTEMP SRL	SGL SPL EXT	LAUNDRY MOTOR EXT WITH THREAD	NONE	1144 STRESSPROOF (C-223)	ROLLED STEEL
6203	6203						

THERMO-PROTECTORS				THERMISTORS	CONTROL	SPACE /n HEATERS
THERMOSTATS	PROTECTORS	WDG RTDs	BRG RTDs			
NONE	AUTOMATIC	NONE	NONE	NONE	FALSE	NONE VOLTS

If Inverter equals NONE, contact factory for further information

*
N
O
T
E
S
*

INVERTER TORQUE: NONE
INV. HP SPEED RANGE: NONE
ENCODER: NONE
NONE NONE
NONE NONE PPR
BRAKE: NONE NONE
NONE P/N NONE
NONE NONE
NONE FT-LB NONE V NONE Hz

DATE: 06/27/2017 06:41:32 AM
 FORM 3531 REV.3 02/07/99

** Subject to change without notice.



REGAL REXNORD CORPORATION
TYPICAL PERFORMANCE CURVE for AC MOTOR

Customer

Curve at 230 Volts
60 HZ
0.33 HP

HP 0.33

PHASE 1

Model No 56C17D2101

VOLTS 115/208-230

Catalog No X601

HZ 60

RPM 1725

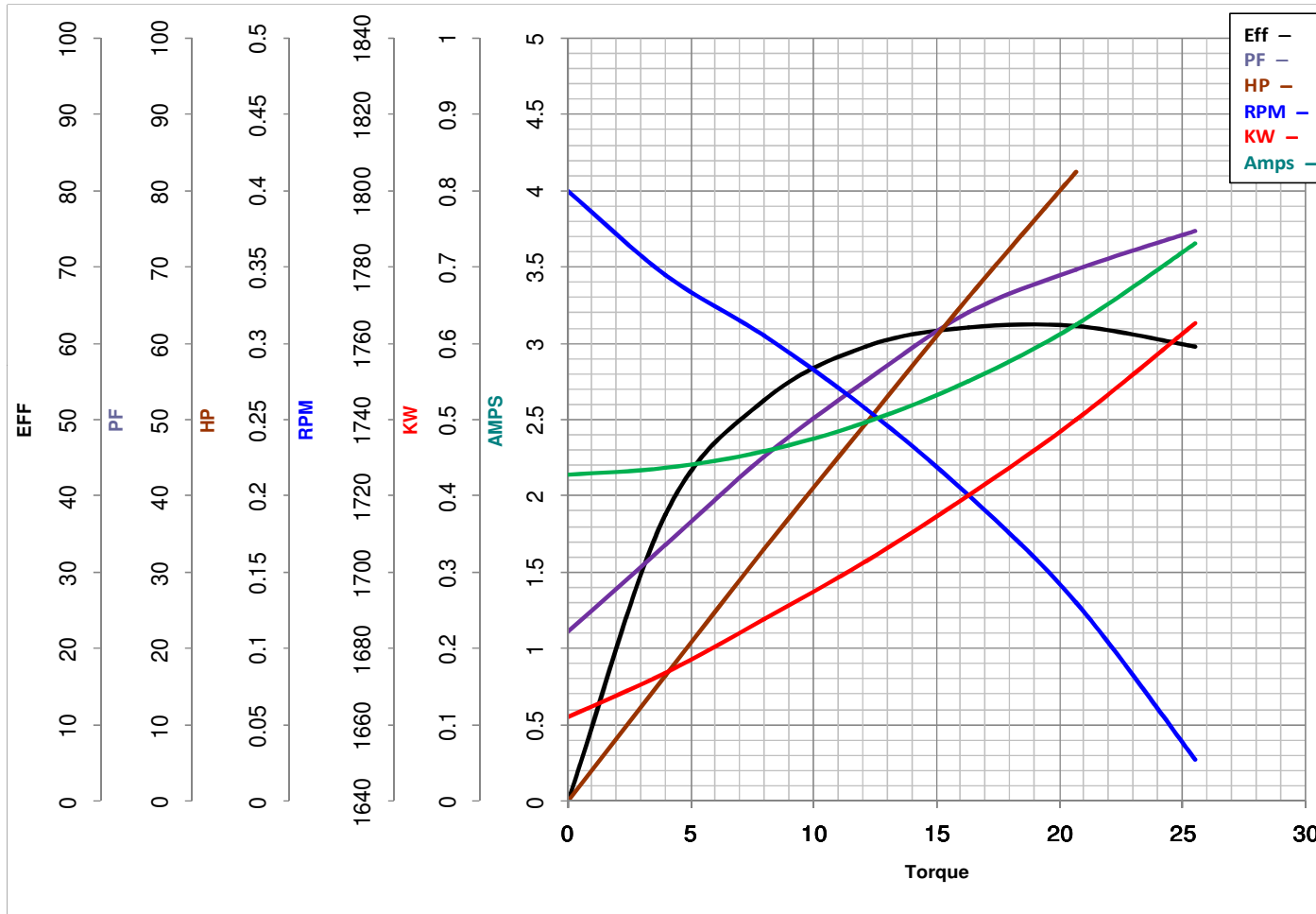

Torque in Oz.Ft

FL TORQUE 16.3 Oz.Ft
BD TORQUE 33.9 Oz.Ft
LR TORQUE 35.5 Oz.Ft

FL AMPS 5.8/2.8-2.9
PU TORQUE 33.0 Oz.Ft
LR AMPS 9.7

WINDING CE4843-3

Date 2/8/2019