

SAUTER AD 9315

3-point bending device with interchangeable attachments

KERN

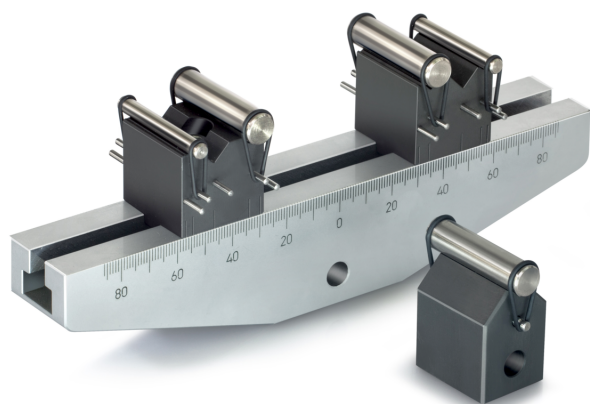

Pictograms

STANDARD



Category

Brand	Sauter
Product category	Measurementtechnology
Product group	Bending device

Construction

Dimension housing (W×D×H)	200×40×30 mm
Dimensions completely mounted (W×D×H)	200×40×30 mm
Material	aluminium
Mounting - force dissipation	Threaded hole M6 External thread M12
Tensile/compressive force [Max]	10 kN

Environmental conditions

Storage temperature [Min]	-10 °C
Storage temperature [Max]	40 °C

Packing & Shipping

Delivery time	14 d
Dimensions packaging (W×D×H)	200×40×30 mm
Shipping method	Parcel service
Net weight approx.	1,6 kg
Gross weight approx.	1,6 kg
Shipping weight	1,5 kg

Product information

GTIN/EAN number	4045761178663
Trade number	90278990
REACH classification	no prohibited substances