

# Raceway Metal Raceway Flexible Sections

# HUBBELL

## Features

- For use with HBL500, HBL700 and HBL750 Series Raceway
- For getting around offsets, side bends, twisted turns or curved surfaces.



## Ordering Information

Description	Color	UPC Number	Catalog Number
Flexible Sections	White	783585423036	HBL5700FWA

## Listings

UL Listed  
CSA Certified

## Specifications

Height	0.2"
Width	0.2"
Length	18.00"

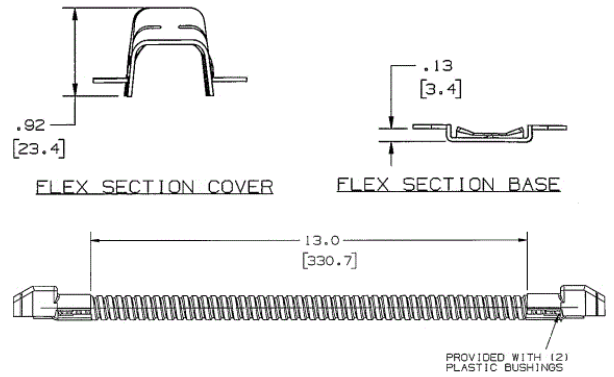

## Online Resources

Customer Use Drawing  
eCatalog  
Installation Instructions