

Raceway
Metal Raceway
Flexible Sections



Features

- For use with HBL500, HBL700 and HBL750 Series Raceway
- For getting around offsets, side bends, twisted turns or curved surfaces.

Ordering Information

Description	Color	UPC Number	Catalog Number
Flexible Sections	White	783585423029	HBL5700FWA



Listings

UL Listed
 CSA Certified

Specifications

Height	0.2"
Width	0.2"
Length	18.00"

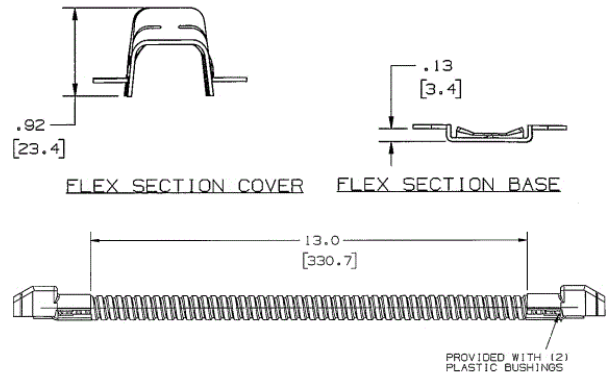

Online Resources

eCatalog

