

Floor Boxes
SystemOne Recessed 2 Gang Floor Box Cover
For Use In Concrete, Raised Access and
Wood Floors

HUBBELL

Features

- 180 degree cover opening to lay flat and reduce tripping hazards
- Two large cable egress doors
- Die cast aluminum cover construction for enhanced durability
- ADA Compliant

Ordering Information

- Compatible with CFB2G25R, CFB2G25RCR, CFB2G30R & CFB2G30RCR
- Surface style typical applications: Carpet, VCT

Catalog Number	UPC Number	Style	Finish
CFBS1R6CVRNKL	783585527857	Surface	Satin Nickel Plated

Dimensions	Floor Finish Insert
7.5 in Diameter	No

Specifications

Cover Material	Aluminum
Flange height	0.125 in.
Adjustment Range	n.a.
Load Rating	1000 lbs. (w/ 2x safety factor)

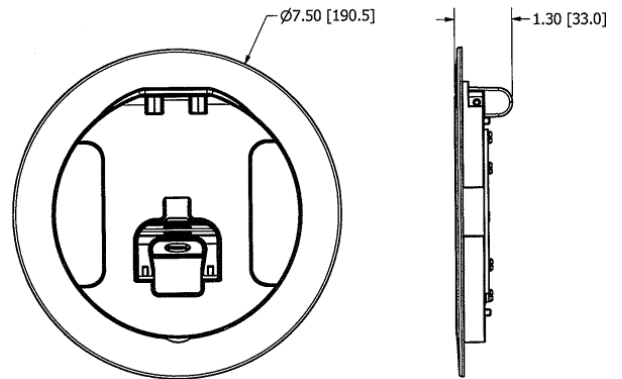

Online Resources

[eCatalog](#)