

Floor Boxes
SystemOne Recessed 2 and 4 Gang Floor Box
Cover

HUBBELL

For Use In Concrete Floors

Features

- 180 degree cover opening to lay flat and reduce tripping hazards
- Two large cable egress doors
- Die cast aluminum cover construction for enhanced durability
- Up to 1 in. of upward post pour adjustment
- ADA Compliant

Ordering Information

- Compatible with CFB2G25, CFB2G25CR, CFB2G30, CFB2G30CR, CFB4G25, CFB4G25CR, CFB4G30 and CFB4G30CR
- Flush style typical applications: Tile, Finished Concrete, Terrazo

Catalog Number 24GTCVRBRS	UPC Number 783585446394	Style Flush	Finish Brass Powder Coat
Dimensions 6-3/16 x 10-5/8 in.	Floor Finish Insert No		

Specifications

Cover Material	Aluminum
Flange height	0.0 in.
Adjustment Range	0 - 1.0 inch
Load Rating	800 lbs. (w/ 2x safety factor)
Power Opening	1 in.
Low Voltage Opening	2 in.

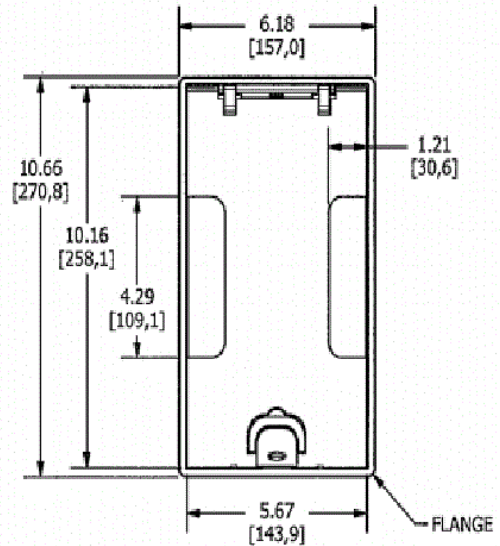

Online Resources

[eCatalog](#)