

Raceway
 Non-Metallic Raceway
 PW2 WallTrak® (Latching) Internal Elbow
 Base and Cover

HUBBELL

Features

- Full capacity 1¼ in. bend radius external elbow.

Ordering Information

Description	Color	UPC Number	Catalog Number
Internal Elbow Base and Cover	Office White	783585090702	PW2IEBC

Listings

UL Listed
 CSA Certified

Specifications

Height	2.32"
Width	2.83"
Length	2.83"

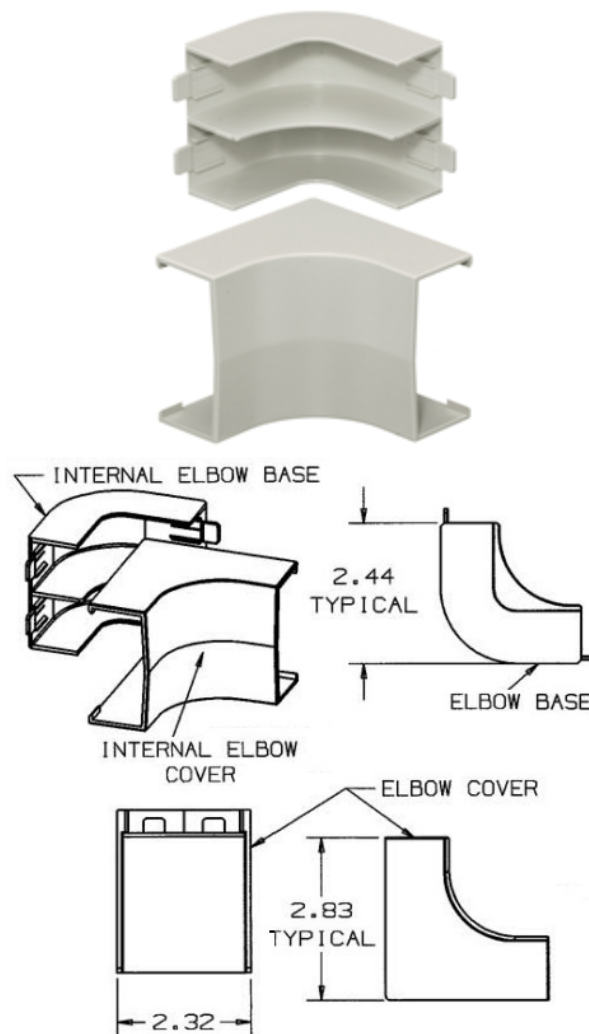

Online Resources

Customer Use Drawing
 eCatalog
 Installation Instructions