

Hub City™ Worm Gear Drives

Single Reduction

PowerCubeX® Worm Speed Reducer Catalog Ratings

Series 320

SERIES	INPUT RPM	RATIO	OUTPUT RPM	CONVENTIONAL OIL					PAO SYNTHETIC OIL			PAG SYNTHETIC OIL		
				MECH. INPUT HP	EFF. %	MECH. OUTPUT TORQUE	THERMAL INPUT HP	THERMAL OUTPUT TORQUE	INPUT HP	EFF. %	OUTPUT TORQUE	INPUT HP	EFF. %	OUTPUT TORQUE
320	2500	5	500	11.17	88.0	1238	7.15	792	11.17	93.2	1313	11.17	96.1	1353
		7.5	333	9.68	87.0	1591	6.50	1068	9.68	92.2	1687	9.68	95.1	1739
		10	250	7.92	86.4	1726	4.54	989	7.92	91.6	1830	7.92	94.5	1886
		15	167	6.51	84.2	2074	3.48	1109	6.51	89.3	2199	6.51	92.1	2267
		20	125	5.31	82.7	2213	2.86	1192	5.31	87.6	2346	5.31	90.3	2419
		25	100	4.51	81.1	2305	2.44	1247	4.51	86.0	2444	4.51	88.7	2519
		30	83.3	4.11	78.5	2437	2.04	1210	4.11	83.2	2584	4.11	85.8	2664
		40	62.5	3.13	75.7	2392	1.69	1292	3.13	80.3	2536	3.13	82.7	2614
		50	50.0	2.54	73.1	2342	1.47	1355	2.54	77.5	2483	2.54	79.9	2560
		60	41.7	2.08	70.7	2222	1.30	1389	2.08	75.0	2355	2.08	77.3	2428
	80	31.3	1.31	67.3	1782	1.22	1660	1.31	71.3	1889	1.31	73.5	1948	
	100	25.0	0.88	63.6	1408	0.84	1344	0.88	67.5	1493	0.88	69.6	1539	
	1750	5	350	10.00	87.3	1518	7.00	1063	10.00	92.6	1609	10.00	95.4	1659
		7.5	233	8.38	86.2	1951	6.40	1490	8.38	91.4	2068	8.38	94.2	2132
		10	175	6.76	85.5	2084	4.40	1356	6.76	90.7	2209	6.76	93.5	2277
		15	117	5.57	83.0	2498	3.35	1502	5.57	88.0	2649	5.57	90.7	2730
		20	87.5	4.59	81.2	2686	2.74	1603	4.59	86.1	2847	4.59	88.7	2935
		25	70.0	3.92	79.4	2805	2.34	1674	3.92	84.2	2973	3.92	86.8	3065
		30	58.3	3.56	76.4	2943	1.94	1604	3.56	81.0	3120	3.56	83.5	3217
		40	43.8	2.75	73.3	2906	1.62	1712	2.75	77.7	3080	2.75	80.1	3176
		50	35.0	2.25	70.5	2851	1.41	1787	2.25	74.7	3022	2.25	77.0	3116
		60	29.2	1.85	67.8	2706	1.25	1828	1.85	71.9	2868	1.85	74.1	2957
	80	21.9	1.20	64.1	2221	1.15	2128	1.20	68.0	2355	1.20	70.1	2427	
	100	17.5	0.80	60.2	1740	0.76	1653	0.80	63.9	1845	0.80	65.8	1902	
	1170	5	234	8.15	86.5	1897	6.22	1448	8.15	91.7	2011	8.15	94.5	2074
		7.5	156	7.09	85.1	2438	4.97	1709	7.09	90.3	2585	7.09	93.1	2665
		10	117	5.74	84.4	2608	4.12	1872	5.74	89.5	2765	5.74	92.2	2850
		15	78.0	5.00	81.4	3142	3.23	2030	5.00	86.3	3330	5.00	89.0	3433
		20	58.5	3.88	79.3	3317	2.56	2189	3.88	84.1	3517	3.88	86.7	3625
		25	46.8	3.29	77.3	3427	2.27	2365	3.29	82.0	3633	3.29	84.5	3745
		30	39.0	3.08	73.9	3681	1.90	2271	3.08	78.3	3902	3.08	80.7	4023
		40	29.3	2.36	70.4	3577	1.62	2455	2.36	74.6	3792	2.36	77.0	3909
		50	23.4	2.00	67.3	3475	1.50	2606	2.00	71.3	3684	2.00	73.5	3798
		60	19.5	1.57	64.4	3277	1.32	2755	1.57	68.3	3474	1.57	70.4	3581
	80	14.6	1.01	60.5	2633	0.95	2477	1.01	64.1	2792	1.01	66.1	2878	
	100	11.7	0.67	56.4	2050	0.64	1958	0.67	59.8	2173	0.67	61.6	2240	
	100	5	20.0	1.25	80.4	3155			1.25	85.2	3345	1.25	87.9	3448
		7.5	13.3	1.10	77.7	4044			1.10	82.4	4287	1.10	84.9	4419
		10	10.0	0.81	76.9	3946			0.81	81.5	4183	0.81	84.0	4313
		15	6.7	0.71	71.4	4794			0.71	75.7	5082	0.71	78.1	5239
20		5.0	0.57	68.2	4898			0.57	72.3	5192	0.57	74.6	5353	
25		4.0	0.48	65.3	4960			0.48	69.2	5258	0.48	71.3	5421	
30		3.3	0.49	59.5	5560			0.49	63.1	5895	0.49	65.0	6077	
40		2.5	0.38	55.0	5247			0.38	58.3	5562	0.38	60.1	5734	
50		2.0	0.31	51.2	5008			0.31	54.3	5309	0.31	55.9	5473	
60		1.7	0.26	47.9	4665			0.26	50.7	4945	0.26	52.3	5098	
80	1.3	0.162	44.0	3605			0.162	46.7	3821	0.162	48.1	3940		
100	1.0	0.110	39.9	2772			0.110	42.2	2939	0.110	43.6	3029		

Worm Gear Drives



ADDITIONAL RATINGS FOR OTHER INPUT SPEEDS ARE AVAILABLE AT WWW.REGALBELOIT.COM

OVERHUNG LOAD AND THRUST LOAD INFORMATION

OVERHUNG LOAD - LOW SPEED SHAFT — MODELS 321 AND 324 1,100 LBS. AT CENTER POINT OF SHAFT EXTENSION.
 MODELS 322 AND 325 NOT APPLICABLE.
 MODELS 327 AND 328 — ±OHL 1,280 LBS., ±THRUST OUT 1,790 LBS. AND ±THRUST IN 1,210 LBS.
 THRUST± UP OR DOWN 1,200 LBS.

±OHL AND THRUST VALUES SHOWN ARE INDEPENDENT FUNCTIONS AND CANNOT BE APPLIED SIMULTANEOUSLY. REFER APPLICATIONS WITH COMBINED OHL AND THRUST TO REGAL CUSTOMER SERVICE DEPARTMENT.

OUTPUT TORQUE VALUES SHOWN ARE INCH-POUNDS (IN-LB).

Hub City™ Worm Gear Drives

Single Reduction Models

135, 155, 185, 215, 245, 265, 305, 325, 385, 425, 455, 525, GW605

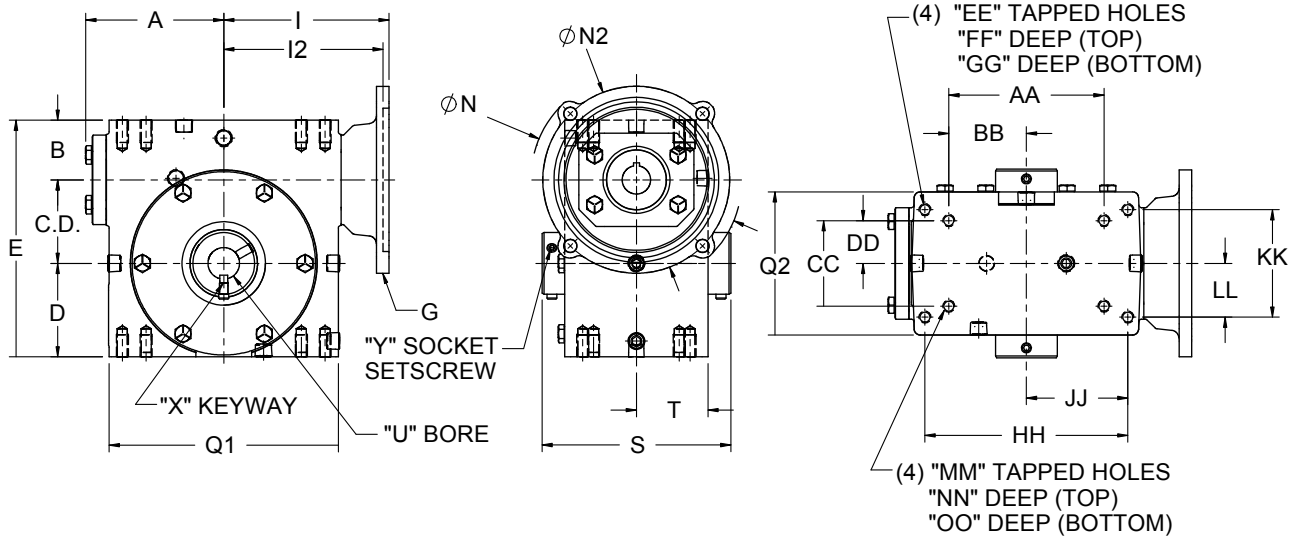

QD™ Bushing Detail for Models 455 & 525

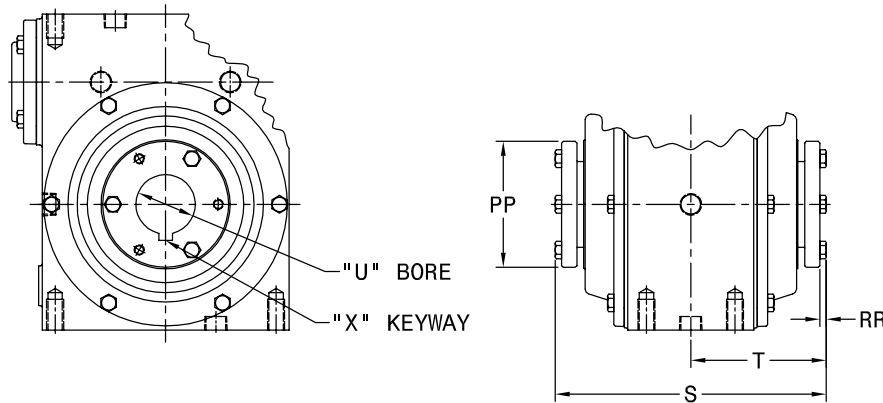

SPECIAL, METRIC AND SAE HYDRAULIC INPUT FLANGES AVAILABLE. CONSULT FACTORY FOR COMPLETE SPECIFICATIONS.

THESE UNITS CAN BE FURNISHED WITH SOLID OUTPUT SHAFT ON SPECIAL ORDERS.

SHAFT MOUNTED UNITS REQUIRE TORQUE ARMS. TORQUE ARM KITS ARE AVAILABLE. SEE PAGE B-105.

ALL GW MODELS ARE FAN COOLED REFER TO FAN DETAILS ON NEXT PAGE.

FOR LUBRICATION AND INSTALLATION INSTRUCTIONS - REFER TO SECTION M

DIMENSIONS SHOWN ARE FOR REFERENCE ONLY.
 DOWNLOAD AVAILABLE CAD MODELS AT: WWW.HUBCITYINC.COM

Standard Styles Available

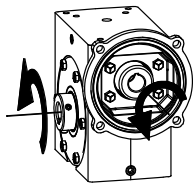

STYLE "A"

NOTE: STYLE "A" SUPPLIED AS STANDARD UNLESS SPECIFIED OTHERWISE.

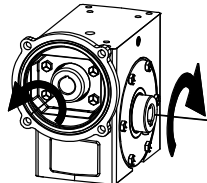

STYLE "B"

NOTE: STYLE B DOES NOT APPLY TO MODELS 455 AND LARGER. HOUSINGS HAVE A COVER ON BOTH SIDES OF OUTPUT.

CONSULT FACTORY FOR VERTICAL SHAFT LUBRICATION RECOMMENDATIONS.

INPUT SHAFT CAN BE ROTATED IN EITHER DIRECTION.



Select hollow output bore models in this product line are now available with the HubLoc® keyless bushing system. Refer to pages i and ii at front of this catalog for features, available sizes, and ordering information.

Hub City™ Worm Gear Drives

Single Reduction Models

135, 155, 185, 215, 245, 265, 305, 325, 385, 425, 455, 525, GW605

MODEL	C.D.	A	B	D	E	Q1	Q2
135	1.334	2.61	1.186	1.562	4.082	4.12	3.12
155	1.541	3.14	1.928	1.906	5.375	4.88	3.44
185	1.751	3.23	1.374	1.875	5.000	5.16	3.44
215	2.064	3.61	1.500	2.437	6.000	5.88	4.12
245	2.376	3.77	2.061	2.500	6.937	6.12	4.06
265	2.626	4.33	1.874	2.938	7.438	7.20	4.50
305	3.001	4.84	2.624	3.250	8.875	8.12	5.25
325	3.251	5.28	2.124	3.250	8.625	8.62	5.20
385	3.751	4.90	2.374	3.937	10.062	9.60	5.62
425	4.251	6.10	2.686	4.438	11.375	10.25	6.13
455	4.501	5.23	2.499	4.625	11.625	9.25	4.63
525	5.168	5.98	2.624	5.375	13.167	10.75	5.06
GW605	6.000	N/A	4.000	6.500	16.500	14.25	8.13

Stock Output Bores

MINIMUM AND MAXIMUM BORE DIMENSIONS SHOWN. FOR ADDITIONAL STOCK OUTPUT BORE SIZES AND STOCK QD™ BUSHING KITS AVAILABLE SEE PAGE B-96.

MODEL	U (MIN.)	U (MAX.)	S	T
135	N/A	5/8	4.50	2.25
155	N/A	5/8	5.42	2.71
185	15/16	1	4.81	2.41
215	15/16	1-1/2	5.56	2.78
245	1	1-1/2	6.00	3.00
265	1	1-1/2	5.93	2.97
305	1-3/16	2-3/16	7.50	3.75
325	1-7/16	2-3/16	7.56	3.78
385	1-7/16	2-3/16	7.56	3.78
425	1-7/16	2-3/16	8.50	4.25
455	QD BUSHING KIT REQUIRED		10.00	5.00
525	QD BUSHING KIT REQUIRED		11.13	5.56
GW605	2	3-7/16	11.50	5.75

Fan Detail for Model GW605

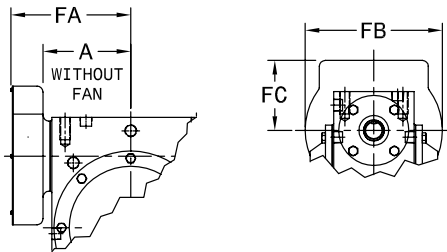

MODEL	A	FA	FB	FC
GW605	N/A	11.13	9.50	4.00

ALL GW MODELS ARE FAN COOLED.

MODEL	AA	BB	CC	DD	EE	FF	GG	HH	JJ	KK	LL	MM	NN	OO	Wt. Lbs.
135	2.250	1.125	1.625	0.813	1/4 UNC	0.50	0.50	3.250	1.625	2.000	1.000	5/16 UNC	0.50	0.50	16
155	4.188	2.094	2.750	1.375	5/16 UNC	0.63	0.63	N/A	N/A	N/A	N/A	N/A	N/A	N/A	16
185	3.125	1.563	1.625	0.813	1/4 UNC	0.50	0.50	4.188	2.094	2.750	1.375	5/16 UNC	0.63	0.63	16
215	4.000	2.000	2.000	1.000	3/8 UNC	0.50	0.70	5.000	2.500	2.875	1.438	3/8 UNC	0.70	0.70	25
245	5.000	2.500	2.875	1.438	3/8 UNC	0.69	0.69	N/A	N/A	N/A	N/A	N/A	N/A	N/A	38
265	4.875	2.438	2.688	1.344	3/8 UNC	0.70	0.70	6.375	3.188	3.375	1.688	3/8 UNC	0.70	0.70	38
305	7.000	3.500	4.000	2.000	7/16 UNC	0.88	0.88	N/A	N/A	N/A	N/A	N/A	N/A	N/A	61
325	6.250	3.125	2.750	1.375	1/2 UNC	0.75	0.75	7.500	3.750	4.000	2.000	7/16 UNC	0.88	0.88	70
385	6.875	3.438	3.000	1.500	1/2 UNC	0.94	1.00	8.500	4.250	4.750	2.375	1/2 UNC	1.00	1.00	86
425	8.500	4.250	5.000	2.500	5/8 UNC	1.00	1.00	N/A	N/A	N/A	N/A	N/A	N/A	N/A	117
455	8.125	4.063	3.250	1.625	5/8 UNC	0.88	1.13	N/A	N/A	N/A	N/A	N/A	N/A	N/A	117
525	9.500	4.750	3.750	1.875	5/8 UNC	1.00	1.25	N/A	N/A	N/A	N/A	N/A	N/A	N/A	145
GW605	12.750	6.375	6.380	3.190	5/8 UNC	1.00	1.00	N/A	N/A	N/A	N/A	N/A	N/A	N/A	330

MODEL	G	I	I2	N	N2
135	48CZ	3.46	N/A	4.36	3.87
	56C			6.63	6.50
155	48CZ	3.99	N/A	4.36	3.87
	56C			6.63	6.50
	143TC				
185	48CZ	4.09	N/A	4.36	3.87
	56C			6.63	6.50
	143TC				
215	48CZ	4.46	N/A	4.36	3.87
	56C			6.63	6.50
	143TC				
245	56C	4.63	N/A	6.50	6.50
	143TC			9.00	9.00
	182TC				
265	56C	5.19	N/A	6.50	6.50
	143TC			9.00	9.00
	182TC				
305	56C	5.95	N/A	6.50	6.50
	143TC			9.00	9.00
	182TC				
	213TC				
325	56C	6.14	N/A	6.50	6.50
	143TC			9.00	9.00
	182TC				
	213TC				
385	56C	6.50	N/A	6.50	6.50
	143TC			9.00	9.00
	182TC				
425	56C	6.45	N/A	6.50	6.50
	143TC			9.00	9.00
	182TC				
	213TC				
	254TC				
455	56C	6.75	N/A	6.50	6.50
	143TC			9.00	9.00
	182TC				
	213TC				
525 *	182TC	N/A	7.50	9.00	9.00
	213TC				
GW605	56C	10.45	N/A	6.50	6.50
	143TC			9.00	9.00
	182TC				
	213TC				
	254TC				

* 56C & 143TC FLANGES AVAILABLE AS MODIFIED STANDARDS